

R&S®UPV-K9/-K92

CDMA2000 Mobile Phone Tests

Operating Manual

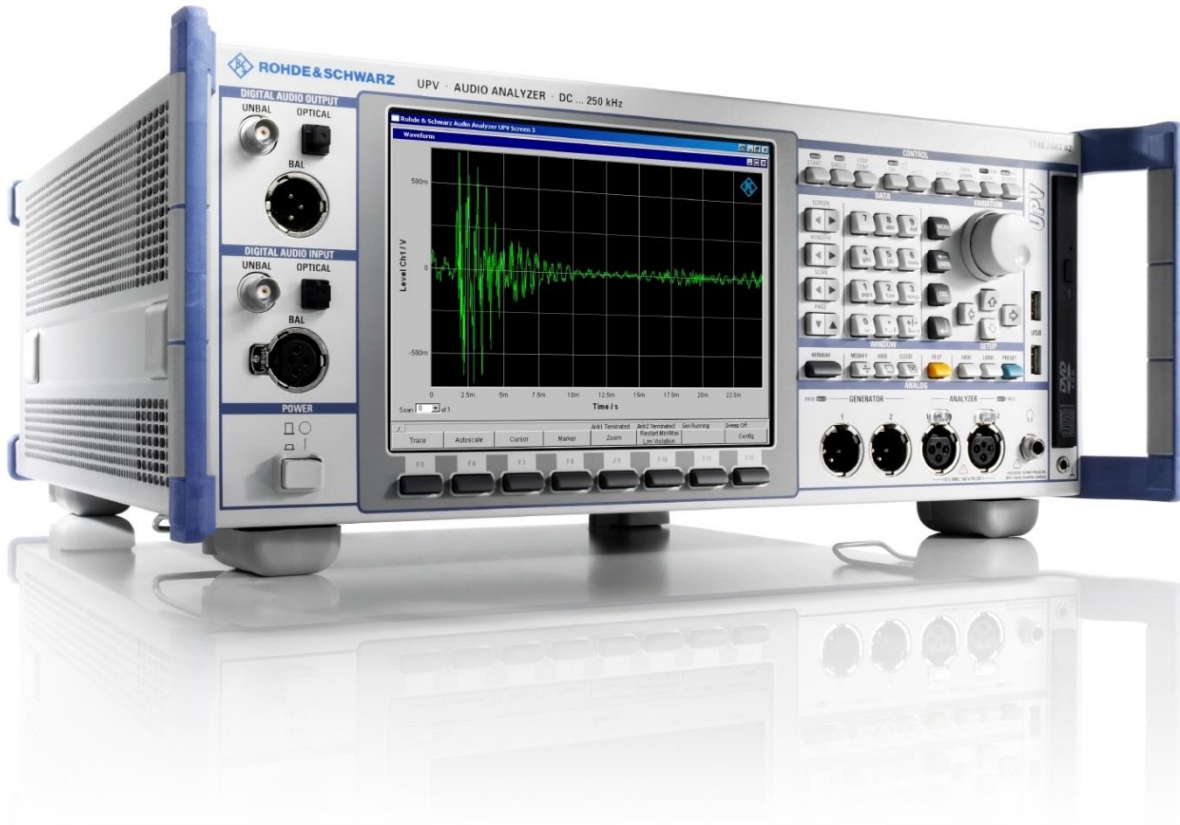

Version 3.0.0



1402.0643.12 – 02

This document describes the R&S®UPV-K9/-K92 CDMA2000 Mobile Phone Tests.

- Material numbers 1402.0008.02 / 1402.0608.02

© 2015 Rohde & Schwarz GmbH & Co. KG

Mühldorfstr. 15, 81671 Munich, Germany

Phone: +49 89 41 29 - 0

Fax: +49 89 41 29 12 164

E-mail: info@rohde-schwarz.com

Homepage: <http://www.rohde-schwarz.com>

Printed in Germany – Subject to change – Data without tolerance limits is not binding.

R&S® is a trademark of Rohde & Schwarz GmbH & Co. KG.

Trade names are trademarks of the owners.

The following abbreviations are used in this manual:

R&S®UPV-K9/-K92 is abbreviated as R&S UPV-K9/-K92

Contents

Basic Safety Instructions

Certificate of Quality

Customer Support

1	Overview	7
2	Preparation and Start of the Application Software	8
	Required Measuring Instruments and Accessories	8
	Installing the Software.....	11
	Verification of the Installation	12
	Test Setup.....	12
	Starting the Application Software	17
3	Operating Concept	21
	Options (General settings)	21
	Standard	21
	Select standard at startup	21
	Ear simulator.....	21
	Select ear simulator at startup	21
	Artificial mouth	21
	Select artificial mouth at startup.....	21
	System simulator	21
	Select system simulator at startup	22
	Hands free settings.....	22
	Activation signal for distortion tests.....	22
	Show Operator Instructions	23
	Auxiliary delay measurements	23
	CMU remote control.....	24
	CMU subsystem.....	24
	Noise Calibration Configuration	24
	Choice of calibration method	25
	Speaker configuration and setup	26
	Bandwidth and tolerance settings	27
	Switcher Usage.....	28
	Other settings	28
	UPP Remote Control	30
	Input Switcher	31
	Report settings.....	32
	Generate temporary export files	32
	Generate temporary image files.....	32
	Store results of further measurements	32
	Do not change scale for further meas.....	32
	Store loaded curve data to results	32
	Enable remote control.....	32

Contents

4	Calibration	33
	Calibration Devices	33
	Microphone Calibration	35
	Calibration of Artificial Ear	36
	Calibration of Ear Type 1	36
	Calibration of Ear Type 3.2 Low Leakage	37
	Reading the Calibration Data of Ear Type 3.2 LL	38
	Calibration of Ear Type 3.2 High Leakage	38
	Reading the Calibration Data of Ear Type 3.2 HL	38
	Calibration of Ear Type 3.3	39
	Reading the DRP-ERP Correction Data of Ear Type 3.3	39
	Reading the Diffuse Field Equalization Data of Ear Type 3.3	40
	Calibration of Ear Type 3.4	40
	Reading the DRP-ERP Correction Data of Ear Type 3.4	40
	Reading the Diffuse Field Equalization Data of Ear Type 3.4	40
	Calibration of Artificial Mouth for Handset Tests	41
	Speech Spectrum Calibration	42
	Calibration of CMU Speech Codec	43
	Calibration of CMW Speech Codec	43
	Calibration of Noise Field for “Speech Quality in Presence of Background Noise” Test	44
	Connections	44
	Establishing the remote control connection between UPV and UPP	45
	Prerequisites	45
	Switcher Support	45
	Starting the calibration process	47
	Stopping and resuming the calibration process	48
	Preparatory Measurements for Delay Measurement	50
	Measurement of Sound Pressure	50
	Measurement of Level Change at Microphone Amplifier Output	50
	Measurement of Level Change at Reference Input	51
	Delay Measurement	51
	Preparatory Measurements for Equalization	54
	Noise Floor	54
	Frequency Response of unequalized Speakers	55
	Total Harmonic Distortion	56
	Cabling Check	57
	Shared Equalization Method	57
	Individual Equalization Method	57
	Level Adjustment	58
	Equalization	58
	All Speaker Post Equalization	60
	Final Test of All Ambiances	61
	Calibration Sections and Resuming Points	61
	Calibration Report	63
5	Data Entry for Reporting	66
	Operator	66
	Test object	66

Contents

6 Measurements.....	67
General	67
Functionality and control of the measurement macros	68
Zooming	69
Changing the Scale of the Graph.....	69
Cursor	69
Data Point Size	70
Making Additional Measurements.....	70
Storing and Loading Curves	70
Storing Curves as Limit Curves	70
Entering a Comment.....	70
Storing a Hardcopy of the Graph	70
Creating a Report.....	71
Closing the Measurement Window	71
Notes on Individual Measurements.....	71
Sending Frequency Response and Loudness Rating.....	71
Sending Frequency Response.....	71
Sending Loudness Rating.....	72
Receiving Frequency Response and Loudness Rating	73
Receiving Frequency Response	73
Receiving Loudness Rating	74
Wideband to Narrowband Loudness Contrast.....	75
Weighted Terminal Coupling Loss (TCLw).....	76
Peak Acoustic Pressure Level	76
Sidetone Masking Rating (STMR)	77
Stability Margin.....	78
Stability Loss	79
Echo Control Characteristics	81
Sending Distortion.....	83
Receiving Distortion	86
Idle Channel Noise Sending.....	88
Idle Channel Noise Receiving	89
Talker Sidetone Delay.....	90
Mobile Station Delay	91
Speech Quality in Presence of Ambient Noise	92
Setup.....	92
Connections	93
Switcher Support.....	93
Prerequisites	95
Measurement.....	95
Continuing broken Measurements	97
Typical Problems during measurement	97
Additional operations when finished.....	99
Extended Speech Quality Measurements.....	99
Continuing broken Extended Measurements.....	100
Notes on Hands-Free Measurements.....	102
General Remarks.....	102
Test Setup.....	102
Acoustic Calibration for Hands Free Tests	104
Customizing Measurements	106
Parameters for the different Measurement Types	108
Sending Response.....	108
Sending Response AMPS	108
Sending Response with Speech “Single Talk”.....	109
Receiving Response	109
Receiving Response AMPS.....	109
Receiving Response with Speech “Single Talk”	110

Contents

Loudness Rating Contrast Calculation	110
Terminal Coupling Loss	111
Terminal Coupling Loss with Compressed Speech “Single Talk”	111
Peak Acoustic Level	112
Sending Noise.....	112
Sending Noise with Activation Signal.....	112
Receiving Noise	113
Receiving Noise with Activation Signal	113
Sending Distortion.....	114
Sending Distortion with Activation Signal.....	115
Receiving Distortion	116
Receiving Distortion with Activation Signal	116
Sidetone Masking Rating	117
Sidetone Masking Rating with Speech “Single Talk”	117
Sidetone Delay with Cross-Correlation	118
Stability Margin.....	118
Stability Loss	118
Delay Measurement with Cross-Correlation	119
Echo Control Characteristics	120
7 Measurements with electric connections	121
Introduction	121
Calibration values for electric connections.....	122
Performing the measurements	122
8 Automatic Test Sequences	123
Creating and Editing a Sequence	123
Remote Control of R&S CMU200 within a Sequence	124
Opening an Existing Sequence.....	125
Running a Sequence.....	125
Running a single measurement out of a sequence.....	126
Reporting on Sequence Results	126
9 Reporting, Storing, Loading and Deleting Results	127
Result Files	127
Report Settings	127
Generating a Single Report.....	127
Selection Report.....	128
Generating a Sequence Report	128
Preview Window.....	128
Storing and Loading Curves from Measurement Windows	129
Storing and Loading Curves from the Results Overview	130
ASCII Result Files	130
Deleting Results	130
Automatic Backup and Restoration of the Results File.....	131
10 Remote Controlled Start of Testcases via GPIB.....	132
Preparations	132
Starting a Measurement.....	132
Reading the Results	132
11 Terminating the Application.....	135
12 Appendix A Settings on the Radio Comm. Tester CMU200	136
13 Appendix B Settings on the Radio Comm. Tester CMW500	140

Basic Safety Instructions

Always read through and comply with the following safety instructions!

All plants and locations of the Rohde & Schwarz group of companies make every effort to keep the safety standards of our products up to date and to offer our customers the highest possible degree of safety. Our products and the auxiliary equipment they require are designed, built and tested in accordance with the safety standards that apply in each case. Compliance with these standards is continuously monitored by our quality assurance system. The product described here has been designed, built and tested in accordance with the EC Certificate of Conformity and has left the manufacturer's plant in a condition fully complying with safety standards. To maintain this condition and to ensure safe operation, you must observe all instructions and warnings provided in this manual. If you have any questions regarding these safety instructions, the Rohde & Schwarz group of companies will be happy to answer them.







Furthermore, it is your responsibility to use the product in an appropriate manner. This product is designed for use solely in industrial and laboratory environments or, if expressly permitted, also in the field and must not be used in any way that may cause personal injury or property damage. You are responsible if the product is used for any purpose other than its designated purpose or in disregard of the manufacturer's instructions. The manufacturer shall assume no responsibility for such use of the product.

The product is used for its designated purpose if it is used in accordance with its product documentation and within its performance limits (see data sheet, documentation, the following safety instructions). Using the product requires technical skills and, in some cases, a basic knowledge of English. It is therefore essential that only skilled and specialized staff or thoroughly trained personnel with the required skills be allowed to use the product. If personal safety gear is required for using Rohde & Schwarz products, this will be indicated at the appropriate place in the product documentation. Keep the basic safety instructions and the product documentation in a safe place and pass them on to the subsequent users.











Observing the safety instructions will help prevent personal injury or damage of any kind caused by dangerous situations. Therefore, carefully read through and adhere to the following safety instructions before and when using the product. It is also absolutely essential to observe the additional safety instructions on personal safety, for example, that appear in relevant parts of the product documentation. In these safety instructions, the word "product" refers to all merchandise sold and distributed by the Rohde & Schwarz group of companies, including instruments, systems and all accessories. For product-specific information, see the data sheet and the product documentation.

Safety labels on products

The following safety labels are used on products to warn against risks and dangers.

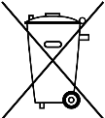
Symbol	Meaning	Symbol	Meaning
	Notice, general danger location Observe product documentation		ON/OFF Power
	Caution when handling heavy equipment		Standby indication
	Danger of electric shock		Direct current (DC)

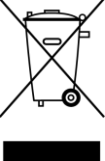
Basic Safety Instructions

Symbol	Meaning	Symbol	Meaning
	Caution ! Hot surface		Alternating current (AC)
	Protective conductor terminal To identify any terminal which is intended for connection to an external conductor for protection against electric shock in case of a fault, or the terminal of a protective earth		Direct/alternating current (DC/AC)
	Earth (Ground)		Class II Equipment to identify equipment meeting the safety requirements specified for Class II equipment (device protected by double or reinforced insulation)
	Frame or chassis Ground terminal		EU labeling for batteries and accumulators For additional information, see section "Waste disposal/Environmental protection", item 1.
	Be careful when handling electrostatic sensitive devices		EU labeling for separate collection of electrical and electronic devices For additional information, see section "Waste disposal/Environmental protection", item 2.
	Warning! Laser radiation For additional information, see section "Operation", item 7.		

Signal words and their meaning

The following signal words are used in the product documentation in order to warn the reader about risks and dangers.



Indicates a hazardous situation which, if not avoided, will result in death or serious injury.



Indicates a hazardous situation which, if not avoided, could result in death or serious injury.



Indicates a hazardous situation which, if not avoided, could result in minor or moderate injury.



Indicates information considered important, but not hazard-related, e.g. messages relating to property damage.
In the product documentation, the word ATTENTION is used synonymously.

These signal words are in accordance with the standard definition for civil applications in the European Economic Area. Definitions that deviate from the standard definition may also exist in other economic areas or military applications. It is therefore essential to make sure that the signal words described here are always used only in connection with the related product documentation and the related product. The use of signal words in connection with unrelated products or documentation can result in misinterpretation and in personal injury or material damage.

Basic Safety Instructions

Operating states and operating positions

The product may be operated only under the operating conditions and in the positions specified by the manufacturer, without the product's ventilation being obstructed. If the manufacturer's specifications are not observed, this can result in electric shock, fire and/or serious personal injury or death. Applicable local or national safety regulations and rules for the prevention of accidents must be observed in all work performed.

1. Unless otherwise specified, the following requirements apply to Rohde & Schwarz products: predefined operating position is always with the housing floor facing down, IP protection 2X, use only indoors, max. operating altitude 2000 m above sea level, max. transport altitude 4500 m above sea level. A tolerance of $\pm 10\%$ shall apply to the nominal voltage and $\pm 5\%$ to the nominal frequency, overvoltage category 2, pollution degree 2.
2. Do not place the product on surfaces, vehicles, cabinets or tables that for reasons of weight or stability are unsuitable for this purpose. Always follow the manufacturer's installation instructions when installing the product and fastening it to objects or structures (e.g. walls and shelves). An installation that is not carried out as described in the product documentation could result in personal injury or even death.
3. Do not place the product on heat-generating devices such as radiators or fan heaters. The ambient temperature must not exceed the maximum temperature specified in the product documentation or in the data sheet. Product overheating can cause electric shock, fire and/or serious personal injury or even death.

Electrical safety

If the information on electrical safety is not observed either at all or to the extent necessary, electric shock, fire and/or serious personal injury or death may occur.

1. Prior to switching on the product, always ensure that the nominal voltage setting on the product matches the nominal voltage of the mains-supply network. If a different voltage is to be set, the power fuse of the product may have to be changed accordingly.
2. In the case of products of safety class I with movable power cord and connector, operation is permitted only on sockets with a protective conductor contact and protective conductor.
3. Intentionally breaking the protective conductor either in the feed line or in the product itself is not permitted. Doing so can result in the danger of an electric shock from the product. If extension cords or connector strips are implemented, they must be checked on a regular basis to ensure that they are safe to use.
4. If there is no power switch for disconnecting the product from the mains, or if the power switch is not suitable for this purpose, use the plug of the connecting cable to disconnect the product from the mains. In such cases, always ensure that the power plug is easily reachable and accessible at all times. For example, if the power plug is the disconnecting device, the length of the connecting cable must not exceed 3 m. Functional or electronic switches are not suitable for providing disconnection from the AC supply network. If products without power switches are integrated into racks or systems, the disconnecting device must be provided at the system level.
5. Never use the product if the power cable is damaged. Check the power cables on a regular basis to ensure that they are in proper operating condition. By taking appropriate safety measures and carefully laying the power cable, ensure that the cable cannot be damaged and that no one can be hurt by, for example, tripping over the cable or suffering an electric shock.

Basic Safety Instructions

6. The product may be operated only from TN/TT supply networks fuse-protected with max. 16 A (higher fuse only after consulting with the Rohde & Schwarz group of companies).
7. Do not insert the plug into sockets that are dusty or dirty. Insert the plug firmly and all the way into the socket provided for this purpose. Otherwise, sparks that result in fire and/or injuries may occur.
8. Do not overload any sockets, extension cords or connector strips; doing so can cause fire or electric shocks.
9. For measurements in circuits with voltages $V_{rms} > 30\text{ V}$, suitable measures (e.g. appropriate measuring equipment, fuse protection, current limiting, electrical separation, insulation) should be taken to avoid any hazards.
10. Ensure that the connections with information technology equipment, e.g. PCs or other industrial computers, comply with the IEC 60950-1 / EN 60950-1 or IEC 61010-1 / EN 61010-1 standards that apply in each case.
11. Unless expressly permitted, never remove the cover or any part of the housing while the product is in operation. Doing so will expose circuits and components and can lead to injuries, fire or damage to the product.
12. If a product is to be permanently installed, the connection between the protective conductor terminal on site and the product's protective conductor must be made first before any other connection is made. The product may be installed and connected only by a licensed electrician.
13. For permanently installed equipment without built-in fuses, circuit breakers or similar protective devices, the supply circuit must be fuse-protected in such a way that anyone who has access to the product, as well as the product itself, is adequately protected from injury or damage.
14. Use suitable overvoltage protection to ensure that no overvoltage (such as that caused by a bolt of lightning) can reach the product. Otherwise, the person operating the product will be exposed to the danger of an electric shock.
15. Any object that is not designed to be placed in the openings of the housing must not be used for this purpose. Doing so can cause short circuits inside the product and/or electric shocks, fire or injuries.
16. Unless specified otherwise, products are not liquid-proof (see also section "Operating states and operating positions", item 1). Therefore, the equipment must be protected against penetration by liquids. If the necessary precautions are not taken, the user may suffer electric shock or the product itself may be damaged, which can also lead to personal injury.
17. Never use the product under conditions in which condensation has formed or can form in or on the product, e.g. if the product has been moved from a cold to a warm environment. Penetration by water increases the risk of electric shock.
18. Prior to cleaning the product, disconnect it completely from the power supply (e.g. AC supply network or battery). Use a soft, non-linting cloth to clean the product. Never use chemical cleaning agents such as alcohol, acetone or diluents for cellulose lacquers.

Operation

1. Operating the products requires special training and intense concentration. Make sure that persons who use the products are physically, mentally and emotionally fit enough to do so; otherwise, injuries or material damage may occur. It is the responsibility of the employer/operator to select suitable personnel for operating the products.

Basic Safety Instructions

2. Before you move or transport the product, read and observe the section titled "Transport".
3. As with all industrially manufactured goods, the use of substances that induce an allergic reaction (allergens) such as nickel cannot be generally excluded. If you develop an allergic reaction (such as a skin rash, frequent sneezing, red eyes or respiratory difficulties) when using a Rohde & Schwarz product, consult a physician immediately to determine the cause and to prevent health problems or stress.
4. Before you start processing the product mechanically and/or thermally, or before you take it apart, be sure to read and pay special attention to the section titled "Waste disposal/Environmental protection", item 1.
5. Depending on the function, certain products such as RF radio equipment can produce an elevated level of electromagnetic radiation. Considering that unborn babies require increased protection, pregnant women must be protected by appropriate measures. Persons with pacemakers may also be exposed to risks from electromagnetic radiation. The employer/operator must evaluate workplaces where there is a special risk of exposure to radiation and, if necessary, take measures to avert the potential danger.
6. Should a fire occur, the product may release hazardous substances (gases, fluids, etc.) that can cause health problems. Therefore, suitable measures must be taken, e.g. protective masks and protective clothing must be worn.
7. Laser products are given warning labels that are standardized according to their laser class. Lasers can cause biological harm due to the properties of their radiation and due to their extremely concentrated electromagnetic power. If a laser product (e.g. a CD/DVD drive) is integrated into a Rohde & Schwarz product, absolutely no other settings or functions may be used as described in the product documentation. The objective is to prevent personal injury (e.g. due to laser beams).
8. EMC classes (in line with EN 55011/CISPR 11, and analogously with EN 55022/CISPR 22, EN 55032/CISPR 32)
 - Class A equipment:
Equipment suitable for use in all environments except residential environments and environments that are directly connected to a low-voltage supply network that supplies residential buildings
Note: Class A equipment is intended for use in an industrial environment. This equipment may cause radio disturbances in residential environments, due to possible conducted as well as radiated disturbances. In this case, the operator may be required to take appropriate measures to eliminate these disturbances.
 - Class B equipment:
Equipment suitable for use in residential environments and environments that are directly connected to a low-voltage supply network that supplies residential buildings

Repair and service

1. The product may be opened only by authorized, specially trained personnel. Before any work is performed on the product or before the product is opened, it must be disconnected from the AC supply network. Otherwise, personnel will be exposed to the risk of an electric shock.

Basic Safety Instructions

2. Adjustments, replacement of parts, maintenance and repair may be performed only by electrical experts authorized by Rohde & Schwarz. Only original parts may be used for replacing parts relevant to safety (e.g. power switches, power transformers, fuses). A safety test must always be performed after parts relevant to safety have been replaced (visual inspection, protective conductor test, insulation resistance measurement, leakage current measurement, functional test). This helps ensure the continued safety of the product.

Batteries and rechargeable batteries/cells

If the information regarding batteries and rechargeable batteries/cells is not observed either at all or to the extent necessary, product users may be exposed to the risk of explosions, fire and/or serious personal injury, and, in some cases, death. Batteries and rechargeable batteries with alkaline electrolytes (e.g. lithium cells) must be handled in accordance with the EN 62133 standard.

1. Cells must not be taken apart or crushed.
2. Cells or batteries must not be exposed to heat or fire. Storage in direct sunlight must be avoided. Keep cells and batteries clean and dry. Clean soiled connectors using a dry, clean cloth.
3. Cells or batteries must not be short-circuited. Cells or batteries must not be stored in a box or in a drawer where they can short-circuit each other, or where they can be short-circuited by other conductive materials. Cells and batteries must not be removed from their original packaging until they are ready to be used.
4. Cells and batteries must not be exposed to any mechanical shocks that are stronger than permitted.
5. If a cell develops a leak, the fluid must not be allowed to come into contact with the skin or eyes. If contact occurs, wash the affected area with plenty of water and seek medical aid.
6. Improperly replacing or charging cells or batteries that contain alkaline electrolytes (e.g. lithium cells) can cause explosions. Replace cells or batteries only with the matching Rohde & Schwarz type (see parts list) in order to ensure the safety of the product.
7. Cells and batteries must be recycled and kept separate from residual waste. Rechargeable batteries and normal batteries that contain lead, mercury or cadmium are hazardous waste. Observe the national regulations regarding waste disposal and recycling.

Transport

1. The product may be very heavy. Therefore, the product must be handled with care. In some cases, the user may require a suitable means of lifting or moving the product (e.g. with a lift-truck) to avoid back or other physical injuries.
2. Handles on the products are designed exclusively to enable personnel to transport the product. It is therefore not permissible to use handles to fasten the product to or on transport equipment such as cranes, fork lifts, wagons, etc. The user is responsible for securely fastening the products to or on the means of transport or lifting. Observe the safety regulations of the manufacturer of the means of transport or lifting. Noncompliance can result in personal injury or material damage.
3. If you use the product in a vehicle, it is the sole responsibility of the driver to drive the vehicle safely and properly. The manufacturer assumes no responsibility for accidents or collisions. Never use the product in a moving vehicle if doing so could distract the driver of the vehicle. Adequately secure the product in the vehicle to prevent injuries or other damage in the event of an accident.

Waste disposal/Environmental protection

1. Specially marked equipment has a battery or accumulator that must not be disposed of with unsorted municipal waste, but must be collected separately. It may only be disposed of at a suitable collection point or via a Rohde & Schwarz customer service center.
2. Waste electrical and electronic equipment must not be disposed of with unsorted municipal waste, but must be collected separately.
Rohde & Schwarz GmbH & Co. KG has developed a disposal concept and takes full responsibility for take-back obligations and disposal obligations for manufacturers within the EU. Contact your Rohde & Schwarz customer service center for environmentally responsible disposal of the product.
3. If products or their components are mechanically and/or thermally processed in a manner that goes beyond their intended use, hazardous substances (heavy-metal dust such as lead, beryllium, nickel) may be released. For this reason, the product may only be disassembled by specially trained personnel. Improper disassembly may be hazardous to your health. National waste disposal regulations must be observed.
4. If handling the product releases hazardous substances or fuels that must be disposed of in a special way, e.g. coolants or engine oils that must be replenished regularly, the safety instructions of the manufacturer of the hazardous substances or fuels and the applicable regional waste disposal regulations must be observed. Also observe the relevant safety instructions in the product documentation. The improper disposal of hazardous substances or fuels can cause health problems and lead to environmental damage.

For additional information about environmental protection, visit the Rohde & Schwarz website.

Instrucciones de seguridad elementales

¡Es imprescindible leer y cumplir las siguientes instrucciones e informaciones de seguridad!

El principio del grupo de empresas Rohde & Schwarz consiste en tener nuestros productos siempre al día con los estándares de seguridad y de ofrecer a nuestros clientes el máximo grado de seguridad. Nuestros productos y todos los equipos adicionales son siempre fabricados y examinados según las normas de seguridad vigentes. Nuestro sistema de garantía de calidad controla constantemente que sean cumplidas estas normas. El presente producto ha sido fabricado y examinado según el certificado de conformidad de la UE y ha salido de nuestra planta en estado impecable según los estándares técnicos de seguridad. Para poder preservar este estado y garantizar un funcionamiento libre de peligros, el usuario deberá atenerse a todas las indicaciones, informaciones de seguridad y notas de alerta. El grupo de empresas Rohde & Schwarz está siempre a su disposición en caso de que tengan preguntas referentes a estas informaciones de seguridad.

Además queda en la responsabilidad del usuario utilizar el producto en la forma debida. Este producto está destinado exclusivamente al uso en la industria y el laboratorio o, si ha sido expresamente autorizado, para aplicaciones de campo y de ninguna manera deberá ser utilizado de modo que alguna persona/cosa pueda sufrir daño. El uso del producto fuera de sus fines definidos o sin tener en cuenta las instrucciones del fabricante queda en la responsabilidad del usuario. El fabricante no se hace en ninguna forma responsable de consecuencias a causa del mal uso del producto.















Instrucciones de seguridad elementales

Se parte del uso correcto del producto para los fines definidos si el producto es utilizado conforme a las indicaciones de la correspondiente documentación del producto y dentro del margen de rendimiento definido (ver hoja de datos, documentación, informaciones de seguridad que siguen). El uso del producto hace necesarios conocimientos técnicos y ciertos conocimientos del idioma inglés. Por eso se debe tener en cuenta que el producto solo pueda ser operado por personal especializado o personas instruidas en profundidad con las capacidades correspondientes. Si fuera necesaria indumentaria de seguridad para el uso de productos de Rohde & Schwarz, encontraría la información debida en la documentación del producto en el capítulo correspondiente. Guarde bien las informaciones de seguridad elementales, así como la documentación del producto, y entréguelas a usuarios posteriores.





Tener en cuenta las informaciones de seguridad sirve para evitar en lo posible lesiones o daños por peligros de toda clase. Por eso es imprescindible leer detalladamente y comprender por completo las siguientes informaciones de seguridad antes de usar el producto, y respetarlas durante el uso del producto. Deberán tenerse en cuenta todas las demás informaciones de seguridad, como p. ej. las referentes a la protección de personas, que encontrarán en el capítulo correspondiente de la documentación del producto y que también son de obligado cumplimiento. En las presentes informaciones de seguridad se recogen todos los objetos que distribuye el grupo de empresas Rohde & Schwarz bajo la denominación de "producto", entre ellos también aparatos, instalaciones así como toda clase de accesorios. Los datos específicos del producto figuran en la hoja de datos y en la documentación del producto.

Señalización de seguridad de los productos

Las siguientes señales de seguridad se utilizan en los productos para advertir sobre riesgos y peligros.

Símbolo	Significado	Símbolo	Significado
	Aviso: punto de peligro general Observar la documentación del producto		Tensión de alimentación de PUESTA EN MARCHA / PARADA
	Atención en el manejo de dispositivos de peso elevado		Indicación de estado de espera (standby)
	Peligro de choque eléctrico		Corriente continua (DC)
	Advertencia: superficie caliente		Corriente alterna (AC)
	Conexión a conductor de protección		Corriente continua / Corriente alterna (DC/AC)
	Conexión a tierra		El aparato está protegido en su totalidad por un aislamiento doble (reforzado)
	Conexión a masa		Distintivo de la UE para baterías y acumuladores Más información en la sección "Eliminación/protección del medio ambiente", punto 1.

Instrucciones de seguridad elementales

Símbolo	Significado	Símbolo	Significado
	Aviso: Cuidado en el manejo de dispositivos sensibles a la electrostática (ESD)	 	Distintivo de la UE para la eliminación por separado de dispositivos eléctricos y electrónicos Más información en la sección "Eliminación/protección del medio ambiente", punto 2.
	Advertencia: rayo láser Más información en la sección "Funcionamiento", punto 7.		

Palabras de señal y su significado

En la documentación del producto se utilizan las siguientes palabras de señal con el fin de advertir contra riesgos y peligros.



Indica una situación de peligro que, si no se evita, causa lesiones graves o incluso la muerte.



Indica una situación de peligro que, si no se evita, puede causar lesiones graves o incluso la muerte.



Indica una situación de peligro que, si no se evita, puede causar lesiones leves o moderadas.



Indica información que se considera importante, pero no en relación con situaciones de peligro; p. ej., avisos sobre posibles daños materiales.

En la documentación del producto se emplea de forma sinónima el término CUIDADO.

Las palabras de señal corresponden a la definición habitual para aplicaciones civiles en el área económica europea. Pueden existir definiciones diferentes a esta definición en otras áreas económicas o en aplicaciones militares. Por eso se deberá tener en cuenta que las palabras de señal aquí descritas sean utilizadas siempre solamente en combinación con la correspondiente documentación del producto y solamente en combinación con el producto correspondiente. La utilización de las palabras de señal en combinación con productos o documentaciones que no les correspondan puede llevar a interpretaciones equivocadas y tener por consecuencia daños en personas u objetos.

Estados operativos y posiciones de funcionamiento

El producto solamente debe ser utilizado según lo indicado por el fabricante respecto a los estados operativos y posiciones de funcionamiento sin que se obstruya la ventilación. Si no se siguen las indicaciones del fabricante, pueden producirse choques eléctricos, incendios y/o lesiones graves con posible consecuencia de muerte. En todos los trabajos deberán ser tenidas en cuenta las normas nacionales y locales de seguridad del trabajo y de prevención de accidentes.

Instrucciones de seguridad elementales

1. Si no se convino de otra manera, es para los productos Rohde & Schwarz válido lo que sigue: como posición de funcionamiento se define por principio la posición con el suelo de la caja para abajo, modo de protección IP 2X, uso solamente en estancias interiores, utilización hasta 2000 m sobre el nivel del mar, transporte hasta 4500 m sobre el nivel del mar. Se aplicará una tolerancia de $\pm 10\%$ sobre el voltaje nominal y de $\pm 5\%$ sobre la frecuencia nominal. Categoría de sobrecarga eléctrica 2, índice de suciedad 2.
2. No sitúe el producto encima de superficies, vehículos, estantes o mesas, que por sus características de peso o de estabilidad no sean aptos para él. Siga siempre las instrucciones de instalación del fabricante cuando instale y asegure el producto en objetos o estructuras (p. ej. paredes y estantes). Si se realiza la instalación de modo distinto al indicado en la documentación del producto, se pueden causar lesiones o, en determinadas circunstancias, incluso la muerte.
3. No ponga el producto sobre aparatos que generen calor (p. ej. radiadores o calefactores). La temperatura ambiente no debe superar la temperatura máxima especificada en la documentación del producto o en la hoja de datos. En caso de sobrecalentamiento del producto, pueden producirse choques eléctricos, incendios y/o lesiones graves con posible consecuencia de muerte.

Seguridad eléctrica

Si no se siguen (o se siguen de modo insuficiente) las indicaciones del fabricante en cuanto a seguridad eléctrica, pueden producirse choques eléctricos, incendios y/o lesiones graves con posible consecuencia de muerte.

1. Antes de la puesta en marcha del producto se deberá comprobar siempre que la tensión preseleccionada en el producto coincida con la de la red de alimentación eléctrica. Si es necesario modificar el ajuste de tensión, también se deberán cambiar en caso dado los fusibles correspondientes del producto.
2. Los productos de la clase de protección I con alimentación móvil y enchufe individual solamente podrán enchufarse a tomas de corriente con contacto de seguridad y con conductor de protección conectado.
3. Queda prohibida la interrupción intencionada del conductor de protección, tanto en la toma de corriente como en el mismo producto. La interrupción puede tener como consecuencia el riesgo de que el producto sea fuente de choques eléctricos. Si se utilizan cables alargadores o regletas de enchufe, deberá garantizarse la realización de un examen regular de los mismos en cuanto a su estado técnico de seguridad.
4. Si el producto no está equipado con un interruptor para desconectarlo de la red, o bien si el interruptor existente no resulta apropiado para la desconexión de la red, el enchufe del cable de conexión se deberá considerar como un dispositivo de desconexión.
El dispositivo de desconexión se debe poder alcanzar fácilmente y debe estar siempre bien accesible. Si, p. ej., el enchufe de conexión a la red es el dispositivo de desconexión, la longitud del cable de conexión no debe superar 3 m).
Los interruptores selectores o electrónicos no son aptos para el corte de la red eléctrica. Si se integran productos sin interruptor en bastidores o instalaciones, se deberá colocar el interruptor en el nivel de la instalación.
5. No utilice nunca el producto si está dañado el cable de conexión a red. Compruebe regularmente el correcto estado de los cables de conexión a red. Asegúrese, mediante las medidas de protección y de instalación adecuadas, de que el cable de conexión a red no pueda ser dañado o de que nadie pueda ser dañado por él, p. ej. al tropezar o por un choque eléctrico.

Instrucciones de seguridad elementales

6. Solamente está permitido el funcionamiento en redes de alimentación TN/TT aseguradas con fusibles de 16 A como máximo (utilización de fusibles de mayor amperaje solo previa consulta con el grupo de empresas Rohde & Schwarz).
7. Nunca conecte el enchufe en tomas de corriente sucias o llenas de polvo. Introduzca el enchufe por completo y fuertemente en la toma de corriente. La no observación de estas medidas puede provocar chispas, fuego y/o lesiones.
8. No sobrecargue las tomas de corriente, los cables alargadores o las regletas de enchufe ya que esto podría causar fuego o choques eléctricos.
9. En las mediciones en circuitos de corriente con una tensión $U_{\text{eff}} > 30 \text{ V}$ se deberán tomar las medidas apropiadas para impedir cualquier peligro (p. ej. medios de medición adecuados, seguros, limitación de tensión, corte protector, aislamiento etc.).
10. Para la conexión con dispositivos informáticos como un PC o un ordenador industrial, debe comprobarse que éstos cumplan los estándares IEC60950-1/EN60950-1 o IEC61010-1/EN 61010-1 válidos en cada caso.
11. A menos que esté permitido expresamente, no retire nunca la tapa ni componentes de la carcasa mientras el producto esté en servicio. Esto pone a descubierto los cables y componentes eléctricos y puede causar lesiones, fuego o daños en el producto.
12. Si un producto se instala en un lugar fijo, se deberá primero conectar el conductor de protección fijo con el conductor de protección del producto antes de hacer cualquier otra conexión. La instalación y la conexión deberán ser efectuadas por un electricista especializado.
13. En el caso de dispositivos fijos que no estén provistos de fusibles, interruptor automático ni otros mecanismos de seguridad similares, el circuito de alimentación debe estar protegido de modo que todas las personas que puedan acceder al producto, así como el producto mismo, estén a salvo de posibles daños.
14. Todo producto debe estar protegido contra sobretensión (debida p. ej. a una caída del rayo) mediante los correspondientes sistemas de protección. Si no, el personal que lo utilice quedará expuesto al peligro de choque eléctrico.
15. No debe introducirse en los orificios de la caja del aparato ningún objeto que no esté destinado a ello. Esto puede producir cortocircuitos en el producto y/o puede causar choques eléctricos, fuego o lesiones.
16. Salvo indicación contraria, los productos no están impermeabilizados (ver también el capítulo "Estados operativos y posiciones de funcionamiento", punto 1). Por eso es necesario tomar las medidas necesarias para evitar la entrada de líquidos. En caso contrario, existe peligro de choque eléctrico para el usuario o de daños en el producto, que también pueden redundar en peligro para las personas.
17. No utilice el producto en condiciones en las que pueda producirse o ya se hayan producido condensaciones sobre el producto o en el interior de éste, como p. ej. al desplazarlo de un lugar frío a otro caliente. La entrada de agua aumenta el riesgo de choque eléctrico.
18. Antes de la limpieza, desconecte por completo el producto de la alimentación de tensión (p. ej. red de alimentación o batería). Realice la limpieza de los aparatos con un paño suave, que no se deshilache. No utilice bajo ningún concepto productos de limpieza químicos como alcohol, acetona o diluyentes para lacas nitrocelulósicas.

Funcionamiento

1. El uso del producto requiere instrucciones especiales y una alta concentración durante el manejo. Debe asegurarse que las personas que manejen el producto estén a la altura de los requerimientos necesarios en cuanto a aptitudes físicas, psíquicas y emocionales, ya que de otra manera no se pueden excluir lesiones o daños de objetos. El empresario u operador es responsable de seleccionar el personal usuario apto para el manejo del producto.
2. Antes de desplazar o transportar el producto, lea y tenga en cuenta el capítulo "Transporte".
3. Como con todo producto de fabricación industrial no puede quedar excluida en general la posibilidad de que se produzcan alergias provocadas por algunos materiales empleados —los llamados alérgenos (p. ej. el níquel)—. Si durante el manejo de productos Rohde & Schwarz se producen reacciones alérgicas, como p. ej. irritaciones cutáneas, estornudos continuos, enrojecimiento de la conjuntiva o dificultades respiratorias, debe avisarse inmediatamente a un médico para investigar las causas y evitar cualquier molestia o daño a la salud.
4. Antes de la manipulación mecánica y/o térmica o el desmontaje del producto, debe tenerse en cuenta imprescindiblemente el capítulo "Eliminación/protección del medio ambiente", punto 1.
5. Ciertos productos, como p. ej. las instalaciones de radiocomunicación RF, pueden a causa de su función natural, emitir una radiación electromagnética aumentada. Deben tomarse todas las medidas necesarias para la protección de las mujeres embarazadas. También las personas con marcapasos pueden correr peligro a causa de la radiación electromagnética. El empresario/operador tiene la obligación de evaluar y señalizar las áreas de trabajo en las que exista un riesgo elevado de exposición a radiaciones.
6. Tenga en cuenta que en caso de incendio pueden desprenderse del producto sustancias tóxicas (gases, líquidos etc.) que pueden generar daños a la salud. Por eso, en caso de incendio deben usarse medidas adecuadas, como p. ej. máscaras antigás e indumentaria de protección.
7. Los productos con láser están provistos de indicaciones de advertencia normalizadas en función de la clase de láser del que se trate. Los rayos láser pueden provocar daños de tipo biológico a causa de las propiedades de su radiación y debido a su concentración extrema de potencia electromagnética. En caso de que un producto Rohde & Schwarz contenga un producto láser (p. ej. un lector de CD/DVD), no debe usarse ninguna otra configuración o función aparte de las descritas en la documentación del producto, a fin de evitar lesiones (p. ej. debidas a irradiación láser).
8. Clases de compatibilidad electromagnética (conforme a EN 55011 / CISPR 11; y en analogía con EN 55022 / CISPR 22, EN 55032 / CISPR 32)
 - Aparato de clase A:
Aparato adecuado para su uso en todos los entornos excepto en los residenciales y en aquellos conectados directamente a una red de distribución de baja tensión que suministra corriente a edificios residenciales.
Nota: Los aparatos de clase A están destinados al uso en entornos industriales. Estos aparatos pueden causar perturbaciones radioeléctricas en entornos residenciales debido a posibles perturbaciones guiadas o radiadas. En este caso, se le podrá solicitar al operador que tome las medidas adecuadas para eliminar estas perturbaciones.
 - Aparato de clase B:
Aparato adecuado para su uso en entornos residenciales, así como en aquellos conectados directamente a una red de distribución de baja tensión que suministra corriente a edificios residenciales.

Reparación y mantenimiento

1. El producto solamente debe ser abierto por personal especializado con autorización para ello. Antes de manipular el producto o abrirlo, es obligatorio desconectarlo de la tensión de alimentación, para evitar toda posibilidad de choque eléctrico.
2. El ajuste, el cambio de partes, el mantenimiento y la reparación deberán ser efectuadas solamente por electricistas autorizados por Rohde & Schwarz. Si se reponen partes con importancia para los aspectos de seguridad (p. ej. el enchufe, los transformadores o los fusibles), solamente podrán ser sustituidos por partes originales. Después de cada cambio de partes relevantes para la seguridad deberá realizarse un control de seguridad (control a primera vista, control del conductor de protección, medición de resistencia de aislamiento, medición de la corriente de fuga, control de funcionamiento). Con esto queda garantizada la seguridad del producto.

Baterías y acumuladores o celdas

Si no se siguen (o se siguen de modo insuficiente) las indicaciones en cuanto a las baterías y acumuladores o celdas, pueden producirse explosiones, incendios y/o lesiones graves con posible consecuencia de muerte. El manejo de baterías y acumuladores con electrolitos alcalinos (p. ej. celdas de litio) debe seguir el estándar EN 62133.

1. No deben desmontarse, abrirse ni triturarse las celdas.
2. Las celdas o baterías no deben someterse a calor ni fuego. Debe evitarse el almacenamiento a la luz directa del sol. Las celdas y baterías deben mantenerse limpias y secas. Limpiar las conexiones sucias con un paño seco y limpio.
3. Las celdas o baterías no deben cortocircuitarse. Es peligroso almacenar las celdas o baterías en estuches o cajones en cuyo interior puedan cortocircuitarse por contacto recíproco o por contacto con otros materiales conductores. No deben extraerse las celdas o baterías de sus embalajes originales hasta el momento en que vayan a utilizarse.
4. Las celdas o baterías no deben someterse a impactos mecánicos fuertes indebidos.
5. En caso de falta de estanqueidad de una celda, el líquido vertido no debe entrar en contacto con la piel ni los ojos. Si se produce contacto, lavar con agua abundante la zona afectada y avisar a un médico.
6. En caso de cambio o recarga inadecuados, las celdas o baterías que contienen electrolitos alcalinos (p. ej. las celdas de litio) pueden explotar. Para garantizar la seguridad del producto, las celdas o baterías solo deben ser sustituidas por el tipo Rohde & Schwarz correspondiente (ver lista de recambios).
7. Las baterías y celdas deben reciclarse y no deben tirarse a la basura doméstica. Las baterías o acumuladores que contienen plomo, mercurio o cadmio deben tratarse como residuos especiales. Respete en esta relación las normas nacionales de eliminación y reciclaje.

Transporte

1. El producto puede tener un peso elevado. Por eso es necesario desplazarlo o transportarlo con precaución y, si es necesario, usando un sistema de elevación adecuado (p. ej. una carretilla elevadora), a fin de evitar lesiones en la espalda u otros daños personales.

Instrucciones de seguridad elementales

2. Las asas instaladas en los productos sirven solamente de ayuda para el transporte del producto por personas. Por eso no está permitido utilizar las asas para la sujeción en o sobre medios de transporte como p. ej. grúas, carretillas elevadoras de horquilla, carros etc. Es responsabilidad suya fijar los productos de manera segura a los medios de transporte o elevación. Para evitar daños personales o daños en el producto, siga las instrucciones de seguridad del fabricante del medio de transporte o elevación utilizado.
3. Si se utiliza el producto dentro de un vehículo, recae de manera exclusiva en el conductor la responsabilidad de conducir el vehículo de manera segura y adecuada. El fabricante no asumirá ninguna responsabilidad por accidentes o colisiones. No utilice nunca el producto dentro de un vehículo en movimiento si esto pudiera distraer al conductor. Asegure el producto dentro del vehículo debidamente para evitar, en caso de un accidente, lesiones u otra clase de daños.

Eliminación/protección del medio ambiente

1. Los dispositivos marcados contienen una batería o un acumulador que no se debe desechar con los residuos domésticos sin clasificar, sino que debe ser recogido por separado. La eliminación se debe efectuar exclusivamente a través de un punto de recogida apropiado o del servicio de atención al cliente de Rohde & Schwarz.
2. Los dispositivos eléctricos usados no se deben desechar con los residuos domésticos sin clasificar, sino que deben ser recogidos por separado.
Rohde & Schwarz GmbH & Co.KG ha elaborado un concepto de eliminación de residuos y asume plenamente los deberes de recogida y eliminación para los fabricantes dentro de la UE. Para desechar el producto de manera respetuosa con el medio ambiente, dirijase a su servicio de atención al cliente de Rohde & Schwarz.
3. Si se trabaja de manera mecánica y/o térmica cualquier producto o componente más allá del funcionamiento previsto, pueden liberarse sustancias peligrosas (polvos con contenido de metales pesados como p. ej. plomo, berilio o níquel). Por eso el producto solo debe ser desmontado por personal especializado con formación adecuada. Un desmontaje inadecuado puede ocasionar daños para la salud. Se deben tener en cuenta las directivas nacionales referentes a la eliminación de residuos.
4. En caso de que durante el trato del producto se formen sustancias peligrosas o combustibles que deban tratarse como residuos especiales (p. ej. refrigerantes o aceites de motor con intervalos de cambio definidos), deben tenerse en cuenta las indicaciones de seguridad del fabricante de dichas sustancias y las normas regionales de eliminación de residuos. Tenga en cuenta también en caso necesario las indicaciones de seguridad especiales contenidas en la documentación del producto. La eliminación incorrecta de sustancias peligrosas o combustibles puede causar daños a la salud o daños al medio ambiente.

Se puede encontrar más información sobre la protección del medio ambiente en la página web de Rohde & Schwarz.

Quality management and environmental management

Certified Quality System
ISO 9001

Certified Environmental System
ISO 14001

Sehr geehrter Kunde,

Sie haben sich für den Kauf eines Rohde&Schwarz Produktes entschieden. Sie erhalten damit ein nach modernsten Fertigungsmethoden hergestelltes Produkt. Es wurde nach den Regeln unserer Qualitäts- und Umweltmanagementsysteme entwickelt, gefertigt und geprüft. Rohde&Schwarz ist unter anderem nach den Managementsystemen ISO9001 und ISO 14001 zertifiziert.

Der Umwelt verpflichtet

- Energie-effiziente, RoHS-konforme Produkte
- Kontinuierliche Weiterentwicklung nachhaltiger Umweltkonzepte
- ISO 14001-zertifiziertes Umweltmanagementsystem

Dear customer,

You have decided to buy a Rohde&Schwarz product. This product has been manufactured using the most advanced methods. It was developed, manufactured and tested in compliance with our quality management and environmental management systems. Rohde&Schwarz has been certified, for example, according to the ISO 9001 and ISO 14001 management systems.

Environmental commitment

- Energy-efficient products
- Continuous improvement in environmental sustainability
- ISO 14001-certified environmental management system

Cher client,

Vous avez choisi d'acheter un produit Rohde&Schwarz. Vous disposez donc d'un produit fabriqué d'après les méthodes les plus avancées. Le développement, la fabrication et les tests de ce produit ont été effectués selon nos systèmes de management de qualité et de management environnemental. La société Rohde&Schwarz a été homologuée, entre autres, conformément aux systèmes de management ISO 9001 et ISO 14001.

Engagement écologique

- Produits à efficience énergétique
- Amélioration continue de la durabilité environnementale
- Système de management environnemental certifié selon ISO 14001



Customer Support

Technical support – where and when you need it

For quick, expert help with any Rohde & Schwarz equipment, contact one of our Customer Support Centers. A team of highly qualified engineers provides telephone support and will work with you to find a solution to your query on any aspect of the operation, programming or applications of Rohde & Schwarz equipment.

Up-to-date information and upgrades

To keep your instrument up-to-date and to be informed about new application notes related to your instrument, please send an e-mail to the Customer Support Center stating your instrument and your wish. We will take care that you will get the right information.

Europe, Africa, Middle East

Phone +49 89 4129 12345
customersupport@rohde-schwarz.com

North America

Phone 1-888-TEST-RSA (1-888-837-8772)
customer.support@rsa.rohde-schwarz.com

Latin America

Phone +1-410-910-7988
customersupport.la@rohde-schwarz.com

Asia/Pacific

Phone +65 65 13 04 88
customersupport.asia@rohde-schwarz.com

China

Phone +86-800-810-8228 /
+86-400-650-5896
customersupport.china@rohde-schwarz.com



1 Overview

The acoustic transmission and reproduction quality of a mobile phone is its most important characteristic in everyday use. Even the most visually appealing design and wonderfully sophisticated operating concept are not much use, when the user cannot or can hardly understand what is being said at the other end.

Instruments and methods for measuring acoustic characteristics are therefore essential tools for assessing the quality and suitability of a mobile phone.

R&S UPV-K92 provides all tests specified in TIA-1042 version 1.0 (3GPP2 C.S0056-0 Version 1.0). It uses the NORMAL real speech signal for sending and receiving frequency response and loudness rating measurements and the ECHOLOSS speech signal for the echo loss measurement.

An additional test case for peak acoustic level is provided. This test uses the PEAKLEV test signal.

For sending measurements, the frequency response of the artificial mouth needs to be equalized. For the equalization of arbitrary signals like the NORMAL speech signal, R&S UPV-K92 provides an off-line filtering tool that compensates the frequency response of the artificial mouth used in order to generate an acoustically correct spectrum of the test signal at the mouth reference point (MRP).

With update key UPV-K9201 present, the program provides in addition all testcases according to TIA-1042-A:2013-03 (3GPP2 C.S0056-A v1.0). This version is harmonized with 3GPP TS 26.132 and uses Single Talk speech signal according to ITU-T P.501 for frequency response tests and a dynamically compressed real speech signal for echo loss tests.

The new testcase "Speech Quality in sending in the Presence of Ambient Noise" requires additional option UPV-K98 and UPV-K101, additional hardware UPP200 with UPP-B8 and UP-Z8A as well as additional acoustic equipment not supplied by Rohde & Schwarz.

2 Preparation and Start of the Application Software

Required Measuring Instruments and Accessories

The Audio Analyzer R&S UPV with the following options is required for the measurements:

- Base Software for Mobile Phone Tests R&S UPV-K9
- CDMA2000[®] Mobile Phone Tests R&S UPV-K92

The CDMA2000[®] 1xRTT mobile phone under test is connected via the RF interface using either the Universal Digital Radio Communication Tester R&S[®] CMU200, called herein below CMU200, or the Wideband Radio Communication Tester R&S[®] CMW500, called herein below CMW500.. This tester simulates a base station for the mobile phone so that a call can be set up. Tests with wideband EVRC codec (SO68 and SO73) are only possible using the CMW500.

The CMU200 must be equipped with the options CMU-B83 v22 (CDMA2000 1xRTT Signalling Unit), CMU-B85 v22 (8k/13k QCELP, 8k EVRC, EVRC-B Speech Codec) and the appropriate software options CMU-K8x for the band used (CMU-K83: 450MHz bands, -K84: Cellular bands, -K85: PCS bands, -K86: IMT-2000 bands). The firmware version in the CMU200 must be 3.50 or higher.

The CMW500 must be equipped with the options CMW-B400B (Audio Board), CMU-B405A (Speech Board), CMW-B200A, CMW-B220A and CMW-PK80.

Acoustic devices such as an artificial mouth, artificial ear and other accessories are required for the measurements. The following equipment from Brüel & Kjær or G.R.A.S. is normally used:

Table 1 Third party acoustic test equipment

Device	Description	Type (examples)
Telephone test head (Only for TIA-1042)	Device for fixing the DUT in the prescribed position	B&K 4602B
Wideband ear simulator (Only for TIA-1042)	IEC 711 type occluded ear simulator with adapters for connection to the ear piece of the DUT	B&K 4195 (type 3.2)
Artificial mouth (Only for TIA-1042)	Special loudspeaker for simulation of the mouth	B&K 4227 or G.R.A.S. 44AB or 44AA (with power amplifier)
Head and torso simulator	Head and torso simulator with artificial ear (type 3.3) and artificial mouth, may be used alternatively to the abovementioned devices	B&K 4128D
Second (left) artificial ear for head and torso simulator	Required for handsfree tests and adjustment of the background noise field for "speech quality in presence of ambient noise"	B&K 4159C (included with 4128D-002)
Handset fixture for Head and Torso simulator	Required to position the handset on the artificial head, and to apply a defined force with the earpiece against the pinna	B&K 4606 (included with 4128D)

Acoustic Measurements on Mobile Phones

Device	Description	Type (examples)
Drive amplifier for artificial mouth	Required for delivering the current into the 5 Ohms load of the loudspeaker. Should have roughly 0 dB voltage gain.	B&K 2735
Measurement microphone	¼" measurement microphone with preamplifier for measurement of artificial mouth output during calibration.	B&K 4939 with B&K 2670 or G.R.A.S. 40BF with G.R.A.S. 26AC
Acoustic calibrator	Sound level calibrator for calibrating the measuring microphone	B&K 4231
¼" Adapter for calibrator	For inserting ¼" microphones into the 4231 calibrator	B&K DP0775
Microphone power supply	Power supply and preamplifier for the measuring microphone	B&K 2829, 5935L or 2690A0S2 or G.R.A.S. 12AR or 12AA

Note: *With the amplifier set to 0 dB, the microphone power supply B&K 2690A0S2 produces too much noise for measuring idle noise and distortion. It is therefore advisable to set a gain of 20 dB.*

Natural speech signals have a high crest factor (approx. 24 dB peak-to-rms value). Therefore, the R&S UPV generator cannot deliver enough peak power to drive the artificial mouth even using the impedance transformer that is supplied along with option R&S UPV-K9. Thus, it is necessary to connect the artificial mouth via an additional audio power amplifier. The generator 1 output of the R&S UPV is connected to the power amplifier input, and the power amplifier output is connected to the artificial mouth.

Any standard small audio power amplifier can be used for this task. An output power of only a few watts is sufficient. The most important factor is the long-term stability of the gain of this amplifier. The voltage gain should be set in to about 0 dB and must remain unchanged after mouth calibration. An amplifier with a means of holding the gain control steady or at least with a lock knob for the volume control is preferred in order to avoid any unwanted gain variation.

For use with Digital Radio Communication Tester CMU200, a cable with male (analyzer) and female (generator) XLR connector is supplied for connection to the "Speech" connector of the Digital Radio Communication Tester CMU200.

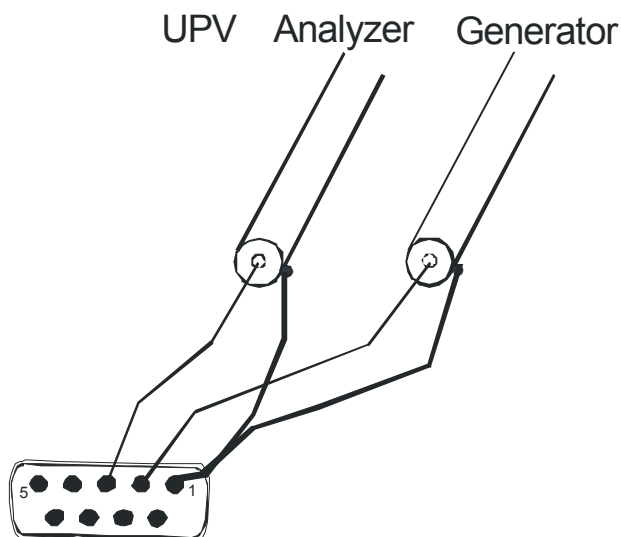

Fig. 1 Assignment of 9-contact speech connector on CMU front panel

This cable is configured for connection to link handler #1 in the CMU200. Depending on the CMU200 hardware, link handler #2 in the CMU200 can also be used for CDMA2000, in particular if the CMU200 also supports GSM and/or WCDMA. In this case, the supplied adapter must be inserted between the cable and the speech connector on the CMU200.

Caution: *If the CMU CODEC calibration fails, the adapter has most likely to be inserted.*

The CMU connects pin 1 of the R&S UPV generator output to the equipment grounding conductor of the mains. If an external power amplifier is used, care must be taken that the external power amplifier does not connect R&S UPV generator output pin 2 to the equipment grounding conductor of the mains. If available, a balanced connection to the power amplifier should be preferred.

An external power amplifier should be switched on after the R&S UPV-K9y program has been started, and switched off before the program is ended. This prevents the artificial mouth from undue power loading by setups which are loaded external to the application.

An external USB keyboard and a mouse must be connected to the R&S UPV.

Caution: *R&S UPV-K9y does not support the use of headphones. Do not connect headphones to the R&S UPV during mobile phone tests. High level signals may be present at the headphone connector.*

The program required and the associated files are in the folder "UPV-K9y Software" on the installation CD supplied with the R&S UPV-K92 option. The audio analyzer must meet the following firmware requirements:

- R&S UPV firmware version 3.3.4.822 or higher
- Option R&S UPV-K9 installed

- Option R&S UPV-K92 installed.
- Testcases according to TIA-1042-A:2013-03 (3GPP2 C.S0056-A v1.0) require update key UPV-K9201. This update key is automatically delivered with every new UPV-K92 option after release of this software version. For older installations this update key can be ordered separately and retro-fitted.

For the testcases “speech quality in sending in the presence of ambient noise” narrowband and wideband the following additional equipment and options are required:

Table 2 Test equipment from R&S required for speech quality tests in the presence of ambient noise

Description	Instrument Type	Ordering Number
R&S® UPV-K98	Background noise control software acc. ETSI ES 202 396-1	1424.2003.02
R&S® UPV-K101	Measurements using background noise acc. ETSI TS 103 106 and EG 202 396-3	1424.2203.02
R&S® UPP200	Audio Analyzer two channels	1411.1003.02
R&S® UPP-B8	Eight-channel generator	1411.2700.02
R&S® UP-Z8A	8-channel analog cable for R&S®UPP-B8	1411.3206.02

The following equipment not supplied by Rohde & Schwarz is also required:

Table 3 Third party equipment required for speech quality tests in the presence of ambient noise

Device	Description	Type (examples)
2 Pairs of full-range speakers	Frequency response at least 100 Hz to 10 kHz	Behringer Truth B2031A
Subwoofer	Frequency response at least 40 Hz to 120 Hz	M-Audio SBX-10
5 Speaker cables	XLR male – XLR female length approx. 10m	
4 Speaker stands	The base plane of the speaker should be adjustable such that the tweeter of the speaker is at the same height as the artificial ears of the head-and-torso simulator. With the B2031A speakers, the tweeter is about 31 cm above the base. With the Bruel & Kjaer HATS, the entrance of the artificial ear is about 60 cm above the base.	

Installing the Software

The application program requires option keys K9 and K92 to be installed. Testcases according to TIA-1042-A:2013-03 (3GPP2 C.S0056-A v1.0) require

option key K9201 to be installed. The keys are installed in the factory in case a new R&S UPV is ordered together with these options. If the options are ordered separately, the keys as well as the installation manual are part of the delivery.

It is recommended to copy the files MCRInstaller.exe, CRRruntime_12_3_mlb.exe, RsVisaTarget_307.msi, UPV-K9y_30065.msi and dotnetfx35.exe from the folder "UPV-K9y Software" on the installation CD to drive D: on the R&S UPV hard disk drive, e.g. to a folder named "D:\R&S Software\UPV-K9y\Version 3.0.0". First, start "MCRInstaller.exe" to install the Matlab runtime for the offline filter tool. Run also "CRRruntime_12_3_mlb.exe". "RsVisaTarget_307.msi" needs only to be run on UPVs with operation system Windows XP. Once installed, it must not be uninstalled. Next, run the file "UPV-K9y_30065.msi" to start the installation. Follow the instructions of the installer on the screen.

Verification of the Installation

After the installation, check the existence of the folder "MATLAB" in "C:\Program Files", and of the subfolder "UPV-K9y Mobile Phone Tests" in "C:\Program Files\Rohde&Schwarz".

If the software reports a missing key code at the first start, delete folder "D:\Phone" (if existing) and install the missing key code before starting the software again.

Test Setup

In the setups using the input switcher, each device type (e.g. free field microphone, right artificial ear, left artificial ear, decoder output) is always assigned to the same switcher input. Therefore connections which are not required for a specific setup do not have to be removed. The schematics below, however, show only the connections required for the specific setup.

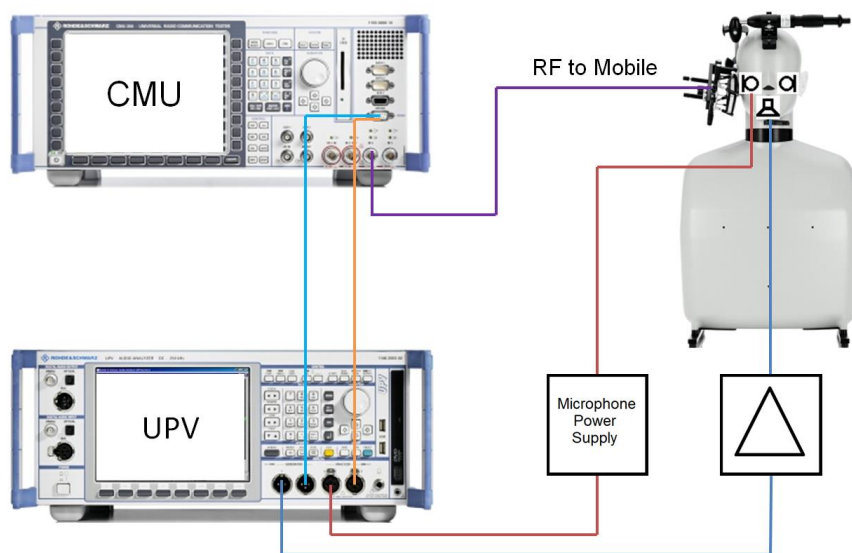

Fig. 2 Test setup and connection of external components with CMU200

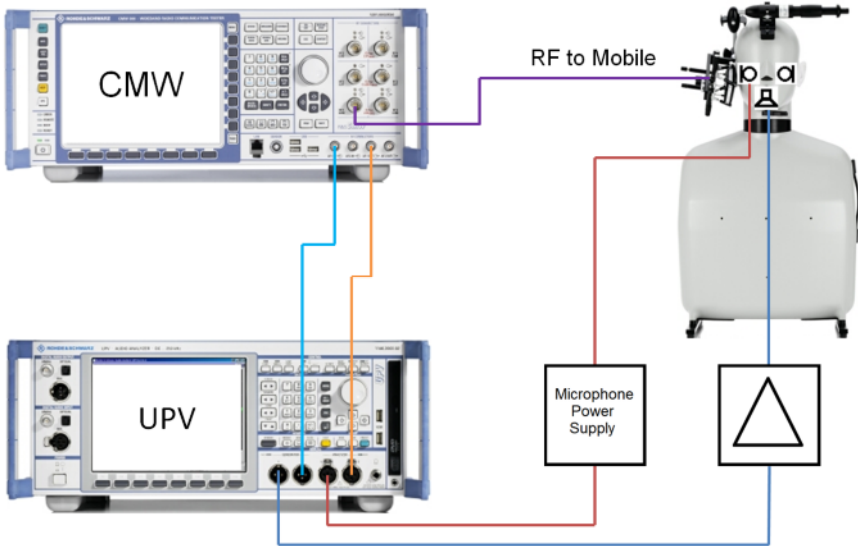

Fig. 3 Test setup and connection of external components with CMW500

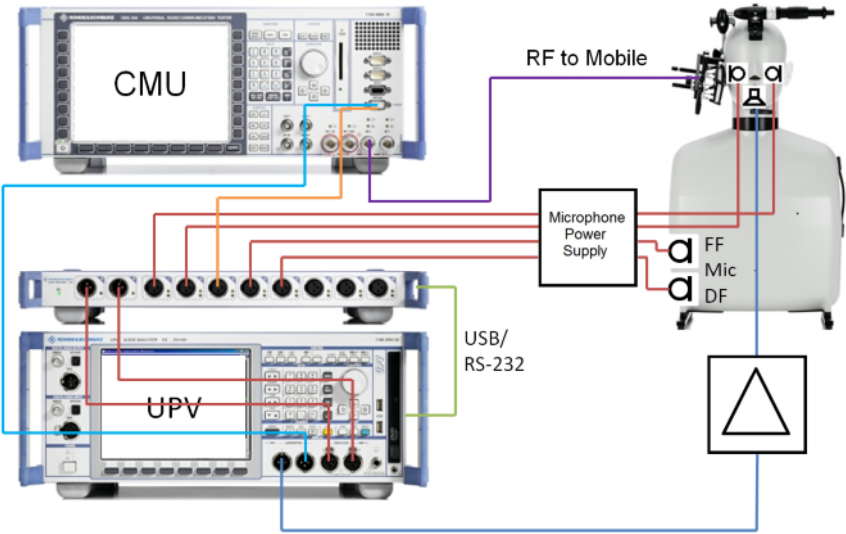

Fig. 4 Test setup and connection of external components with input switcher UPZ and CMU200

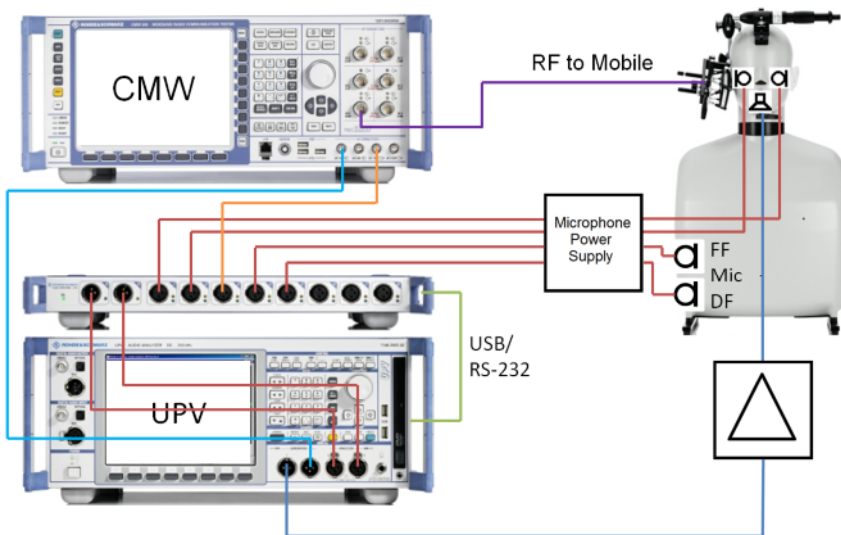

Fig. 5 Test setup and connection of external components with input switcher UPZ and CMW500

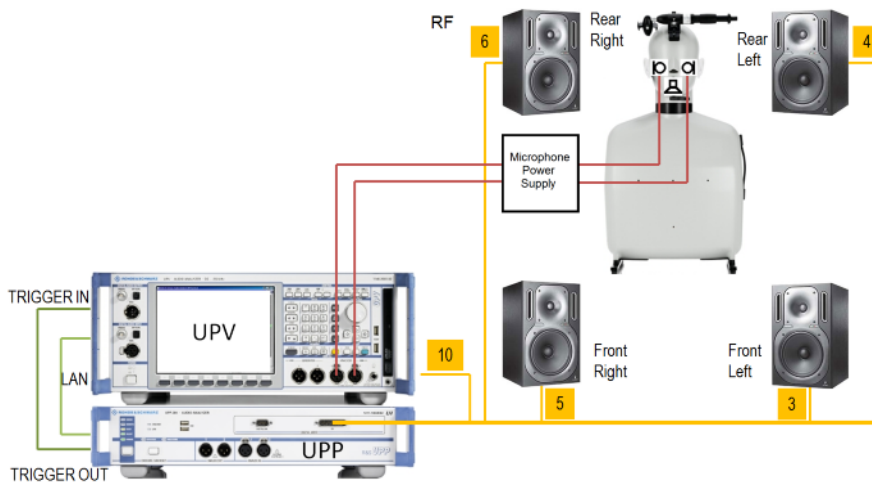

Fig. 6 Test setup and connection of external components for the adjustment of the background noise field

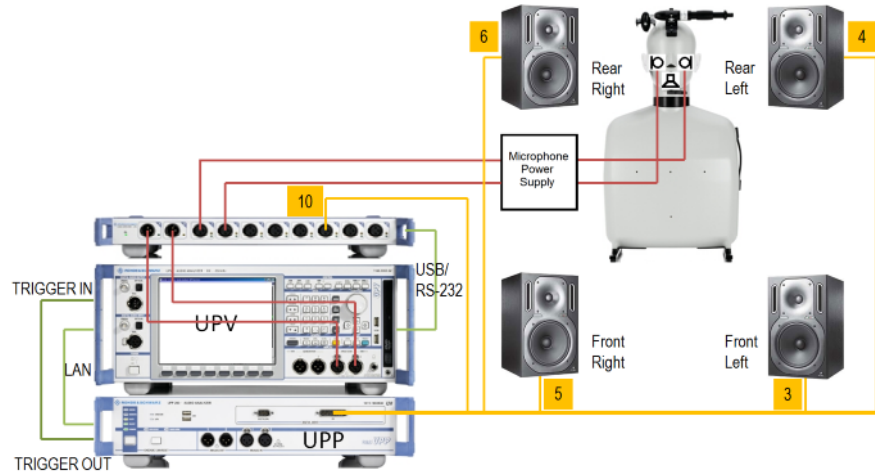

Fig. 7 Test setup and connection of external components with input switcher UPZ for the adjustment of the background noise field

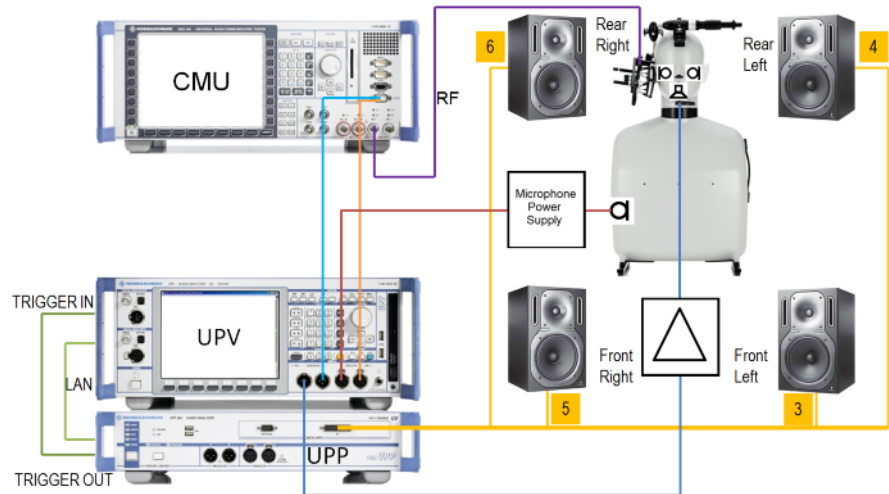

Fig. 8 Test setup and connection of external components with CMU200 for measurements with background noise field

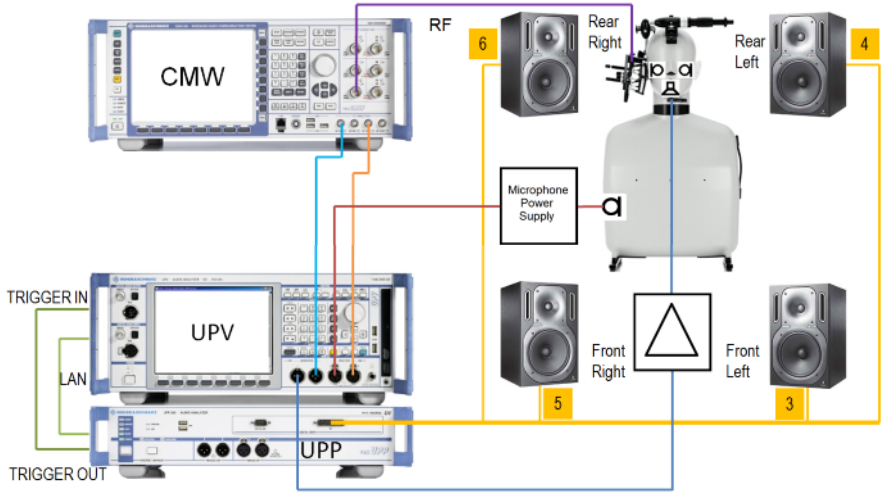

Fig. 9 Test setup and connection of external components with CMW500 for measurements with background noise field

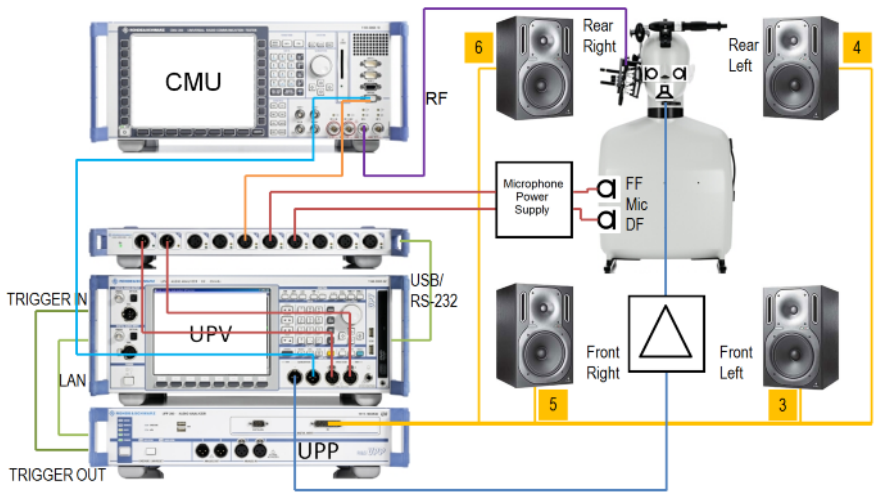

Fig. 10 Test setup and connection of external components with CMU200 and input switcher UPZ for measurements with background noise field

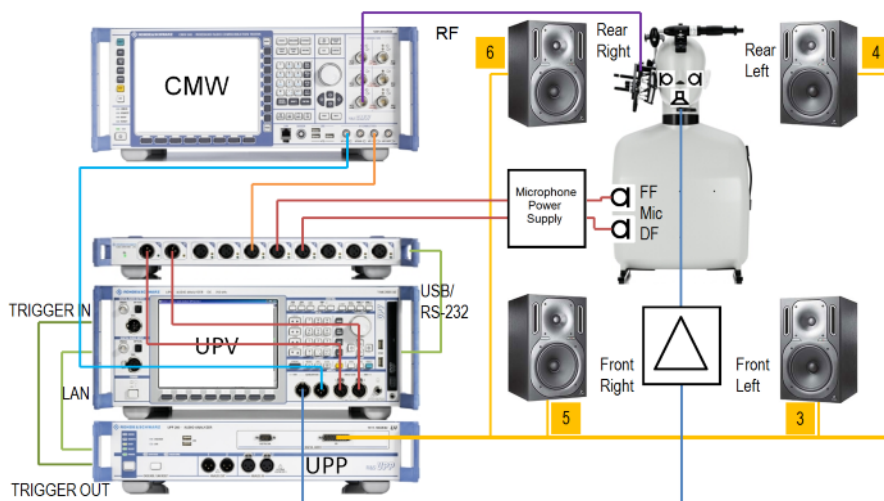

Fig. 11 Test setup and connection of external components with CMW500 and input switcher UPZ for measurements with background noise field

Starting the Application Software

After installation, the program can be started by double-clicking the Icon “UPV-K9y Mobile Phone Tests” or by clicking “R&S UPV Applications → UPV-K9y Mobile Phone Tests” in the “Programs” menu.

At the first start of the program, selection windows appear for the standard according to which the measurements should be made, and for the artificial ear and artificial mouth used.

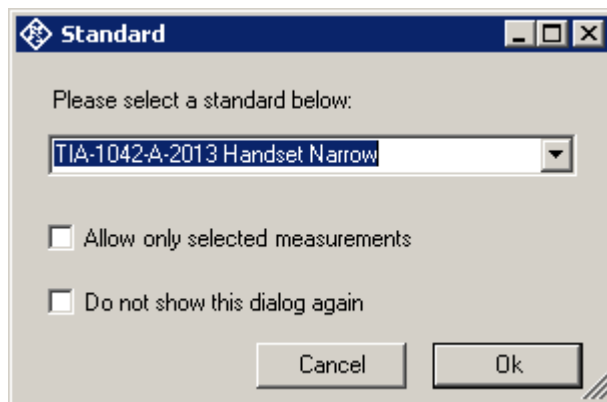

Fig. 12 Query window for selection of applied standard

If “No Standard” is selected in the standard selection window, all measurements appear in the “Measurement” menu. If a standard is selected, all measurements appear in the “Measurement” menu, but compliant measurements are checked. If “Allow only standard measurements” is checked, non-compliant measurements are suppressed in the Measurement menu.

“TIA-1042:2005” comprises sending and receiving tests (frequency response and loudness rating) for CDMA2000 and AMPS, weighted terminal coupling loss and the maximum acoustic pressure test from annex B. “TIA-1042:2005 and Auxiliaries” comprises in addition sidetone masking

rating, sending and receiving distortion and idle channel noise tests according to 3GPP standard. These tests are not specified in TIA-1042 and offered for information only.

“TIA-1042-A-2013 Handset Narrow” and “TIA-1042-A-2013 Handset Wide” offer all testcases according to the updated standard for narrowband and wideband connections, respectively. “TIA-1042-A-2013 Handset Narrow and Auxiliaries” and “TIA-1042-A-2013 Handset Wide and Auxiliaries” provide additional testcases according to 3GPP TS 26.132 Release 11.

While 3GPP2 C.S0056-A and TIA-1042-A-2013 do not specify testcases for handsfree devices, the present software provides tests for handheld handsfree, desktop handsfree and vehicle-mounted handsfree devices according to 3GPP TS 26.132 Release 11 in Standards “CDMA2k HHHF Narrow”, “CDMA2k HHHF Wide”, “CDMA2k DTHF and VMHF Narrow” and “CDMA2k DTHF and VMHF Wide”.

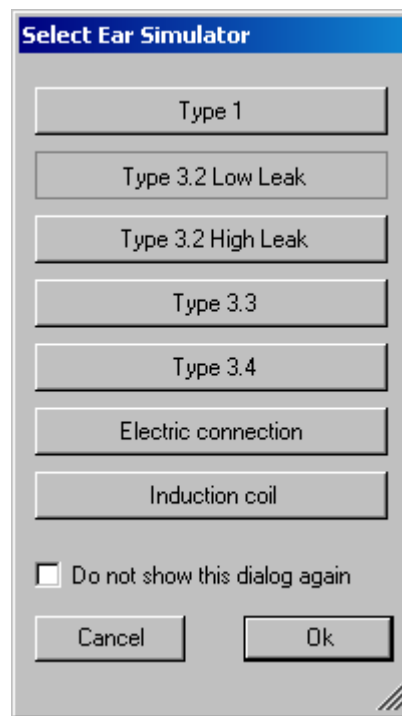

Fig. 13 Query window for selection of artificial ear

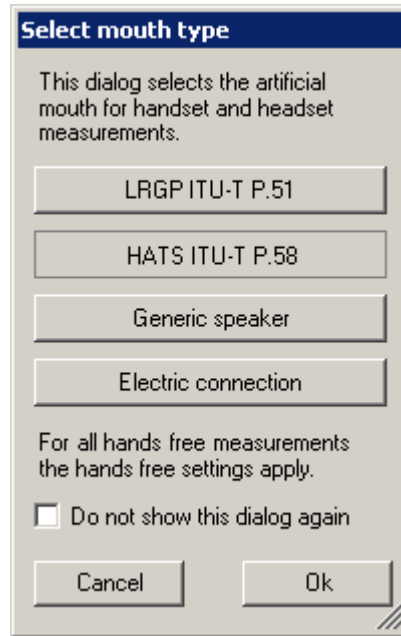

Fig. 14 Query window for selection of artificial mouth

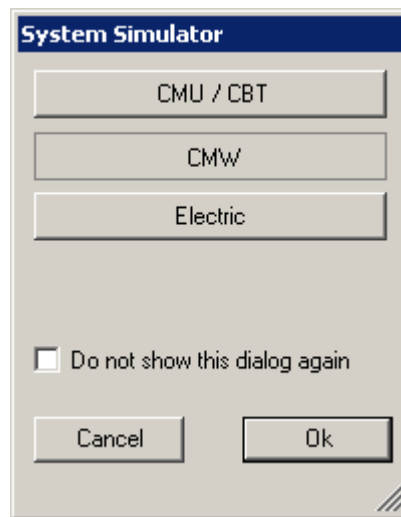

Fig. 15 Query window for selection of system simulator

When the checkbox “Do not show this dialog again” is checked, the corresponding selection window will not appear at the program start in future. However, the selection is still available in the “Options” menu (see below). After the last of the three selection windows has been closed, the main window of the R&S UPV-K9 opens.

Select	Date and time	Measurement title	Test object	Verdict	Main Result
<input type="checkbox"/>	02/27/2015 13:06:32	3GPP2 Sending Handset Narrowband	UE 2	PASS	Sending Loudness Rating
<input type="checkbox"/>	02/27/2015 13:07:34	3GPP2 Weighted Terminal Coupling Loss, NB	UE 2	PASS	Echo Loss = 49.8 dB
<input type="checkbox"/>	02/27/2015 13:09:33	3GPP2 Idle Channel Noise Sending NB	UE 2	PASS	Idle Channel Noise Sendir
<input type="checkbox"/>	02/27/2015 13:10:08	3GPP2 STMR NB, Nominal Volume Setting	UE 2	FAIL	Sidetone Masking Rating
<input type="checkbox"/>	02/27/2015 13:11:08	3GPP2 Talker Sidetone Delay	UE 2	PASS	(null)
<input type="checkbox"/>	02/27/2015 13:11:42	3GPP2 Receiving Handset NB, nom. Vol.	UE 2	FAIL	RLR = -10.7 dB
<input type="checkbox"/>	02/27/2015 13:12:29	3GPP2 Idle channel noise receiving, max. vol.	UE 2	FAIL	Idle Channel Noise Receiv
<input type="checkbox"/>	02/27/2015 13:12:47	3GPP2 Sending Handset Narrowband	UE 2	PASS	Sending Loudness Rating
<input type="checkbox"/>	02/27/2015 13:13:31	3GPP2 Weighted Terminal Coupling Loss, NB	UE 2	PASS	Echo Loss = 45.1 dB
<input type="checkbox"/>	02/27/2015 13:14:32	3GPP2 Idle Channel Noise Sending NB	UE 2	FAIL	Idle Channel Noise Sendir
<input type="checkbox"/>	02/27/2015 13:14:47	3GPP2 STMR NB, Nominal Volume Setting	UE 2	FAIL	Sidetone Masking Rating
<input type="checkbox"/>	02/27/2015 13:15:31	3GPP2 Talker Sidetone Delay	UE 2	PASS	(null)
<input type="checkbox"/>	02/27/2015 14:34:29	3GPP2 Receiving Handset NB, nom. Vol.	UE 2	FAIL	RLR = -35.6 dB
<input type="checkbox"/>	02/27/2015 14:35:33	3GPP2 Idle channel noise receiving, max. vol.	UE 2	PASS	Idle Channel Noise Receiv
<input type="checkbox"/>	02/27/2015 14:35:52	3GPP2 Sending Handset Narrowband	UE 2	FAIL	Sending Loudness Rating
<input type="checkbox"/>	02/27/2015 14:36:51	3GPP2 Weighted Terminal Coupling Loss, NB	UE 2	PASS	Echo Loss = 92.2 dB
<input type="checkbox"/>	02/27/2015 14:37:53	3GPP2 Idle Channel Noise Sending NB	UE 2	PASS	Idle Channel Noise Sendir
<input type="checkbox"/>	02/27/2015 14:38:08	3GPP2 STMR NB, Nominal Volume Setting	UE 2	FAIL	Sidetone Masking Rating
<input type="checkbox"/>	02/27/2015 14:39:09	3GPP2 Talker Sidetone Delay	UE 2	FAIL	(null)
<input type="checkbox"/>	02/27/2015 15:00:01	3GPP2 Receiving Handset NB, nom. Vol.	UE 2	FAIL	RLR = -35.6 dB
<input type="checkbox"/>	02/27/2015 15:01:05	3GPP2 Idle channel noise receiving, max. vol.	UE 2	PASS	Idle Channel Noise Receiv
<input type="checkbox"/>	02/27/2015 15:01:23	3GPP2 Sending Handset Narrowband	UE 2	FAIL	Sending Loudness Rating
<input type="checkbox"/>	02/27/2015 15:02:23	3GPP2 Weighted Terminal Coupling Loss, NB	UE 2	PASS	Echo Loss = 92.2 dB
<input type="checkbox"/>	02/27/2015 15:03:25	3GPP2 Idle Channel Noise Sending NB	UE 2	PASS	Idle Channel Noise Sendir
<input type="checkbox"/>	02/27/2015 15:09:10	3GPP2 Receiving Handset NB, nom. Vol.	UE 2	FAIL	RLR = -35.6 dB
<input type="checkbox"/>	02/27/2015 15:10:14	3GPP2 Idle channel noise receiving, max. vol.	UE 2	PASS	Idle Channel Noise Receiv
<input type="checkbox"/>	02/27/2015 15:10:32	3GPP2 Sending Handset Narrowband	UE 2	FAIL	Sending Loudness Rating

Fig. 16 Main window

Initially the data grid in the center of the screen which shows the result overview is empty. The screenshot in Fig.6 shows an example after a number of measurements have been made.

3 Operating Concept

R&S mobile phone tests consist of at least two components. R&S UPV-K9 provides the main user interface window, general settings, calibration routines, data handling, automatic sequencing and reporting tools.

Separate options for different standards (R&S UPV-K92 for CDMA2000 tests) provide test macros for basic measurement types defined in the standards. Each measurement type provides a set of parameters (R&S UPV setup files, limits etc.) which are defined in separated measurement definition files, one for each test case.

Options (General settings)

The “Options” menu in the main window allows to change a set of general settings like ear type and mouth type used which are valid for all or at least a plurality of the tests.

Standard

“Standard” allows to select one of the available standards. Measurements belonging to this standard will be checked in the measurement menu. If “Allow only standard measurements” is checked, it is not possible to start single measurements which do not belong to the standard.

Select standard at startup

If “Select standard at startup” is checked, the selection window for the standard is opened at each start of the program.

Ear simulator

“Ear simulator” allows to select the type of ear simulator used for handset and headset tests. For details on the handling of calibration data see section 4 “Calibration” below.

Select ear simulator at startup

If “Select ear simulator at startup” is checked, the selection window for the ear simulator is opened at each start of the program.

Artificial mouth

“Artificial mouth” allows to select the type of artificial mouth used for handset and headset tests. For details on the handling of calibration data see section 4 “Calibration” below.

Select artificial mouth at startup

If “Select artificial mouth at startup” is checked, the selection window for the artificial mouth is opened at each start of the program.

System simulator

“System simulator” allows to select the type of system simulator used. For details on the handling of calibration data see section 4 “Calibration” below.

Select system simulator at startup

If “Select system simulator at startup” is checked, the selection window for the system simulator is opened at each start of the program.

Hands free settings

“Hands free settings” allows selecting the acoustic instruments used for hands free testing. It is possible to use an ITU-T P.51 artificial mouth together with a free field microphone, a HATS with one artificial ear or a HATS with two artificial ears. If two artificial ears are used, the decoder has to be disconnected from analyzer input 2 and the second artificial ear has to be connected to it for receiving measurements. Do not forget to re-connect the decoder for any measurement in sending direction. Alternatively a UPZ input switcher can be used for automatic connection of the sound sources to the UPV analyzer inputs.

Activation signal for distortion tests

In the sub-menu to “Activation signal for distortion tests”, signals can be imported to the test system. If more than one imported signal is available, it is possible to choose one of them for actual use.

Import Activation Signal

Browse to an appropriate wave file.
The file must be recorded in mono with 48 kHz sample rate.
Maximum permissible length is 10 seconds.

File Name

D:\NUPV\User\Male#1_1_48kHz.wav

Sample Rate Hz

Mono Stereo

Duration Seconds

Average Level dBFS

Active Level dBFS

Equalise for Selected Artificial Mouth

Immediately select this activation signal

Fig. 17 Window for import of activation signals

Use the “Browse” button to select a wave file which fulfills the conditions shown on top of the window. The selected signal is analyzed and checked for appropriateness. Note that a high crest factor of the signal may

overdrive the codec or artificial mouth. If “Equalize for Selected Artificial Mouth” is activated, the file is immediately equalized for the selected artificial mouth when the “Ok” button is clicked. Otherwise or when the mouth calibration has been re-done or a different artificial mouth has been selected in the meantime, the signal is equalized automatically immediately before the sending distortion test starts.

If “Immediately select this activation signal” is checked, the signal is selected for use when the “Ok” button is clicked.

Show Operator Instructions

If “Show operator instructions” is checked, instructions to the operator are displayed in a window before the measurement starts. The operator may be prompted to position the mobile in a defined way or to set the volume to a certain setting

Auxiliary delay measurements

For the alignment of the acquisition with the arrival of the test signal at the analyzer input, an auxiliary end-to-end delay measurement is performed before the main measurement. The item “Auxiliary delay measurements → Configure” allows to select the measurement method (sine burst or cross correlation), the test signal for the cross correlation method (composite source signal or real speech word “five”) and the re-use of a delay value which has been measured for the same device under test on the same path for a previous test. A maximum age has to be specified for the use of existing delay values to avoid the use of outdated values.

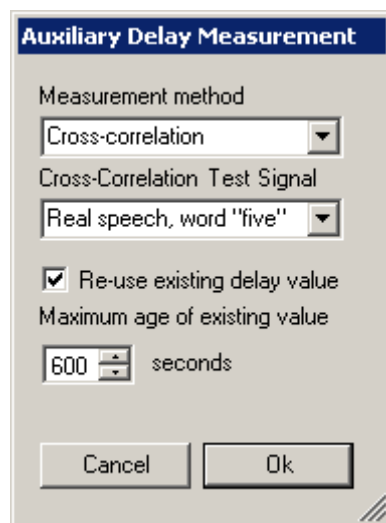

Fig. 18 Window for configuration of auxiliary delay measurements

The recommended method for auxiliary delay measurement is cross-correlation using the real speech word “five” as test signal. Re-use of existing delay results speeds up the tests, which is particularly helpful in automatic test sequences. It avoids changing of the test setup when uplink and downlink delay values are required for echo loss and stability loss tests. However, if changes are done in the setup which could have an influence on the end-to-end delay, like changing the device under test, the codec or codec rate etc, the auxiliary delay measurement has to be re-run. If a different device under test is selected in menu item “Data → Test object →

Select "...", the memorized auxiliary delay values are automatically invalidated. In all other cases the operator has to invalidate them using menu item "Auxiliary delay measurements → Invalidate all existing values".

CMU remote control

If it is intended to remote control a R&S CMU200 from a sequence of this program, menu item "CMU remote control" can be used to select the communication interface (GPIB or RS-232) and, if multiple devices are found, to select one of them.

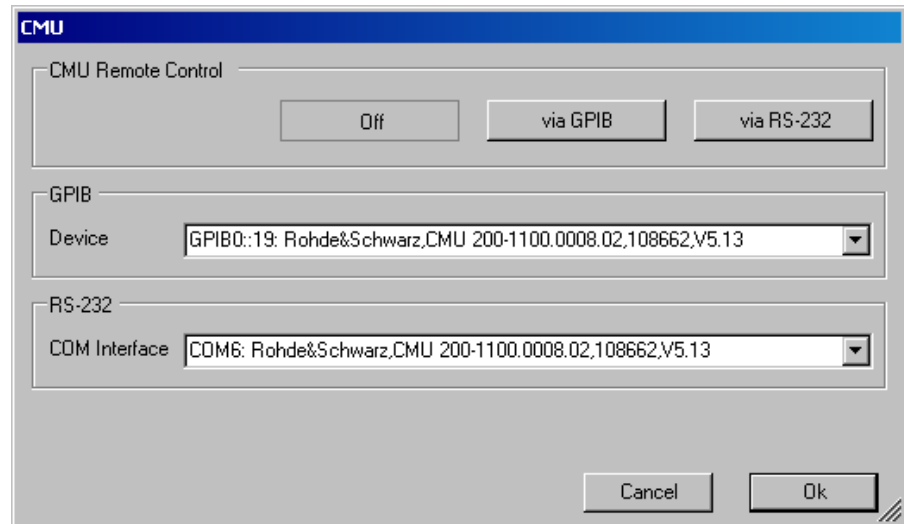

Fig. 19 Window for configuring the CMU remote control

For remote control via RS-232, an external USB-to-serial converter has to be connected and installed. For remote control via GPIB, the R&S VISA has to be installed. The installer for the R&S VISA is distributed with the Option R&S UPV-K92. For details of the remote control see section 8 and the operation manuals of the R&S CMU200.

CMU subsystem

In "CMU subsystem", one of the communication standards can be selected. This allows sequences to be run in different communication standards without changing the subsystem in every single CMU control instance in the sequence.

Noise Calibration Configuration

In "Noise Calibration Configuration" parameters for the background noise field used for the "Speech Quality in Presence of Ambient Noise" test can be set.

The configuration of the noise field calibration comprises

1. Choice of the calibration method
2. Speaker configuration and setup
3. Bandwidth and tolerance settings
4. Switcher usage

5. Other settings.

It is done in the 'Noise Calibration Configuration' window. This window is opened with item 'Noise calibration configuration' in the "Options" menu. The figure below shows the default settings. If any item has been changed then user can retain the default settings by selecting the button "Set to default".

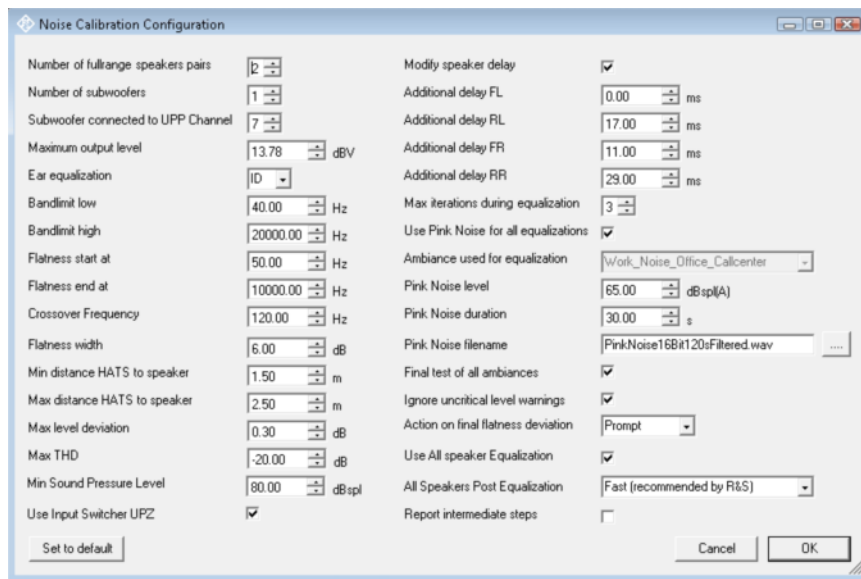

Fig. 20 Noise Calibration Configuration Window, Default state.

The configuration is saved in the settings of the UPV-K9y program, so that any modification will be effective and re-used as long as the speaker configuration and calibration methods do not need to be changed.

Choice of calibration method

Three different calibration methods are available which differ in time consumption and accuracy:

Pink Noise Equalization (recommended by Rohde & Schwarz) equalizes speaker and room with an uncorrelated, non-periodical Pink Noise signal and uses this equalization for all ambiances. It offers the best compromise between calibration time and accuracy. After room equalization with the pink noise signal only an individual level correction has to be done for each ambiance.

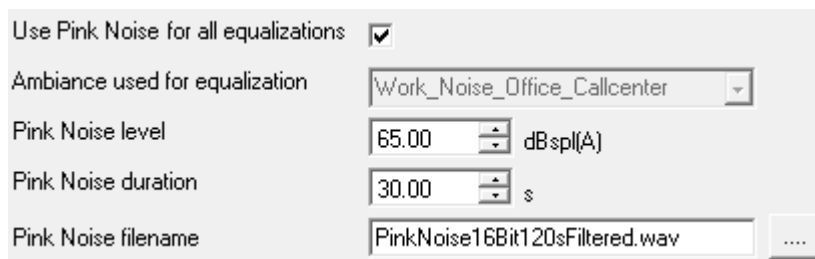

Fig. 21 Configuration Window, calibration method Pink Noise.

Although it is not recommended to change the default settings, a user can select level and duration of the Pink Noise. Specifying a longer duration

results in longer calibration time but might increase the accuracy especially at low frequencies. Instead of using the recommended WAV file the user could provide an own noise file.

Shared equalization with one ambiance (recommended by ETSI ES 202 396) equalizes speaker and room with one of the ambiances and uses this equalization for all other ambiances, too. Because the real ambiances do not contain the same energy in each frequency band, the equalization is optimal only for the selected ambiance.

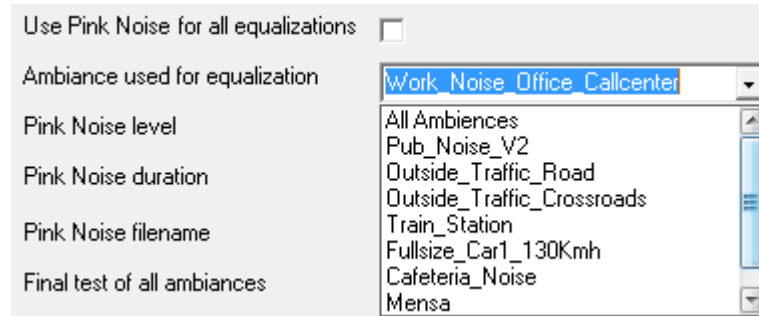

Fig. 22 Configuration Window, calibration method shared ambiance.

This method takes the same calibration time as Pink Noise but normally offers worse accuracy. After room equalization, the individual level correction has to be done for each ambiance.

Individual equalization of each ambiance results in best equalization accuracy but makes the calibration process more than 3 times longer (about 8 hours). It could be considered if the room and speaker setup will never be changed.

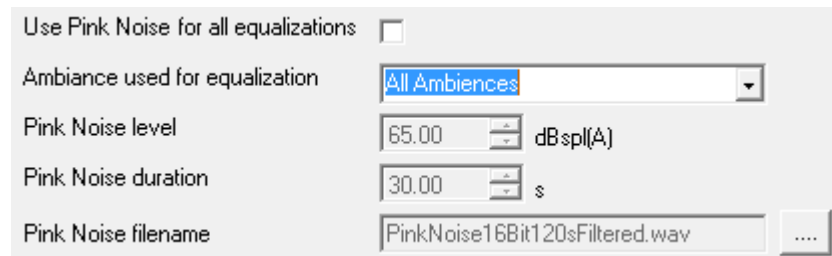

Fig. 23 Configuration Window, calibration method individual ambiance.

Speaker configuration and setup

Currently two different speaker configurations are allowed for background noise generation:

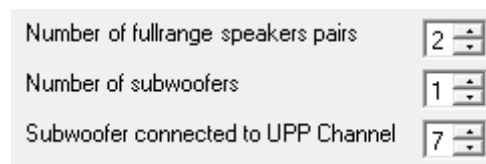
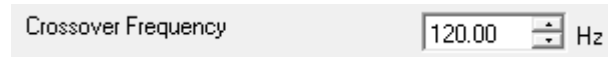

Fig. 24 Configuration Window, speaker configuration.

4 full range speakers (2 pairs) with 1 subwoofer or 4 full range speakers without subwoofer. A subwoofer must be used if the full range speakers do not pass frequencies down to 50 Hz. The full range speakers are connected

to UPP channel 3...6. The optional subwoofer is connected to channel 7. UPP channel 10 is reserved for connection to UPV output.

If a subwoofer is used, the crossover frequency between full range speakers and subwoofer can be adjusted:



Crossover Frequency Hz

Fig. 25 Configuration Window, speaker crossover frequency.

To avoid overdriving maximum input voltage of the speakers (or amplifiers), the operator can adjust the UPP maximum (RMS) output level:

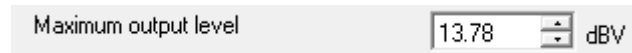

Maximum output level dBV

Fig. 26 Configuration Window, speaker maximal output level.

At the beginning of the calibration process, checks for each speaker are performed to achieve a minimum sound pressure level and to detect speaker overdrive by measuring THD. The operator is instructed to increase the speaker (or amplifier) gain if the required sound level could not be reached. The required sound pressure level can be set in the range from 80 to 99 dBspl:

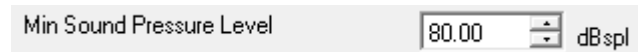

Min Sound Pressure Level dBspl

Fig. 27 Configuration Window, speaker Min Sound Pressure Level.

For speakers that generate higher harmonic distortion than 10% (-20 dB), the tolerable THD can be increased (to e.g. -10 dB):

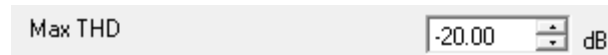

Max THD dB

Fig. 28 Configuration Window, speaker Max THD.

To detect left/right speaker connection faults, the calibration process needs to know the rough speaker-to-microphone distances. If the test room is much larger or smaller than the recommended size, the operator has to adjust the minimum or maximum speaker distance:

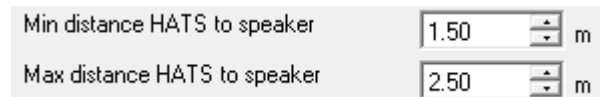

Min distance HATS to speaker m
Max distance HATS to speaker m

Fig. 29 Configuration Window, expected HATS to speaker distance.

Bandwidth and tolerance settings

The bandlimits specify the frequency range where the equalization will be performed.

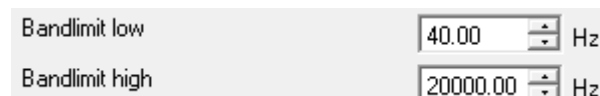

Bandlimit low Hz
Bandlimit high Hz

Fig. 30 Configuration Window, Bandlimit.

The 'low' value additionally enables a highpass filter. To *include* the lowest third octave (50 Hz), the lower bandlimit should be lower or equal to a half third octave ($f / 1.122$) below. To *exclude* the 40 Hz third octave from equalization, the bandlimit low should be set to 44.5 Hz

Flatness check is limited to the frequency range between start and end.

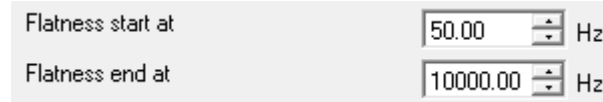

Flatness start at 50.00 Hz
Flatness end at 10000.00 Hz

Fig. 31 Configuration Window, Flatness range.

According to ETSI ES 202 396 the equalization must be flat to +/-3 dB, thus the flatness width must not be greater than 6 dB.

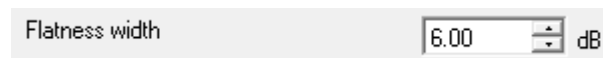

Flatness width 6.00 dB

Fig. 32 Configuration Window, Flatness width.

To achieve an even better flatness this value might be reduced by 1 or 2 dB, if room and speaker setup are able to fulfil such narrow flatness.

Switcher Usage

To reduce user interaction during calibration and measurement an R&S Input switcher UPZ can be used. This allows hard wired connection to be established between each signal source and the UPZ while the calibration process automatically switches the required UPZ input channels to UPV input



Use Input Switcher UPZ

Fig. 33 Configuration Window, Use Input Switcher UPZ.

Other settings

All other configuration settings normally need not to be changed. User should modify these settings only to change the default behaviour of the calibration.

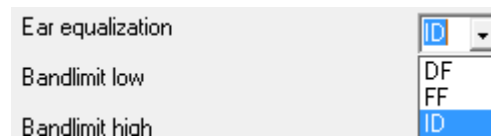

Ear equalization ID
Bandlimit low DF
Bandlimit high FF

Fig. 34 Configuration Window, Ear equalization.

Instead of using ID ear equalization (Independent of Direction), 'free field (FF)' or 'diffuse field (DF)' ear equalization can be selected.

Modify speaker delay	<input checked="" type="checkbox"/>
Additional delay FL	0.00 ms
Additional delay RL	17.00 ms
Additional delay FR	11.00 ms
Additional delay RR	29.00 ms

Fig. 35 Configuration Window, Modify speaker delay.

To avoid coherent superposition of sound from two speakers reproducing the same signal, the determined speaker delay is individually increased. Only experienced users should modify these settings to fix acoustical problems!

Max iterations during equalization	3
------------------------------------	---

Fig. 36 Configuration Window, Max iterations during equalization.

To achieve flat frequency response, several iterations of equalization are performed for single and pair of speakers. Iteration is terminated if flatness is better than 1 dB or 'Max iterations during equalization' is reached. This value can be selected between 1 (no iteration) and 5.

Action on final flatness deviation	Prompt
Use All speaker Equalization	Prompt
	Retry once
	Retry twice

Fig. 37 Configuration Window, Action on final flatness deviation.

This item specifies how the calibration process should behave if – after all iteration steps – the flatness deviation is higher than 'Flatness width'. By default it would prompt the operator how to proceed (retry, ignore or abort). To avoid this interruption of calibration process, the operator can predefine if (and how often) the measurement should be retried.

Max level deviation	0.30 dB
---------------------	---------

Fig. 38 Configuration Window, Max level deviation.

During level adjustment the sound pressure level of each speaker is iterated to the requested value. This iteration terminates if the level deviation is below the selected 'Max level deviation'. To achieve higher level accuracy this value can be decreased; however, this might increase the count of iteration steps and total calibration time.

Ignore uncritical level warnings	<input checked="" type="checkbox"/>
----------------------------------	-------------------------------------

Fig. 39 Configuration Window, Ignore uncritical warnings.

To avoid interruption of calibration process, by default only *errors* are reported to user. *Warnings* about uncritical deviations (e.g. noise floor, flatness of unequalised room, level deviation during single speaker adjustment) are suppressed, but entered in report.

To get uncritical warning as soon as they appear, this tick box has to be

deactivated.

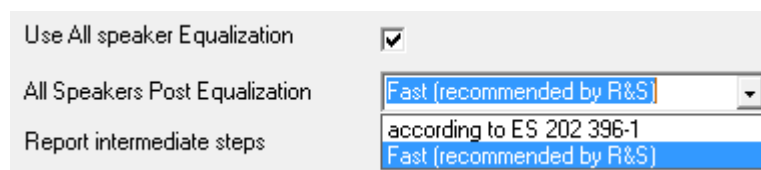

Fig. 40 Configuration Window, Use All speaker Equalization.

If the sound super positioning of all speakers degrades the flatness to more than 6 dB (or the selected 'flatness width') a post equalization process should be used to improve this flatness. Otherwise the calibration would fail!

Instead of using the R&S recommended algorithm, the post equalization can be done according to ES 202 396-1.

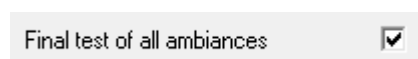

Fig. 41 Configuration Window, Final test of all ambiances.

After successful calibration a final level and equalization test of all ambiances should be performed. Additionally this test adjusts the total level setting to minimum deviation.

Disabling this test reduces the total calibration time.

The final test of successfully calibrated noise field (but without level optimization) can be performed separately from the calibration process by executing the calibration and skipping all calibration steps.



Fig. 42 Configuration Window, report intermediate steps.

In case of problems during the calibration process the operator can activate a detailed reporting that logs all intermediate steps.

Selecting 'Report intermediate steps' does not increase total calibration time but the number of pages in the report.

UPP Remote Control

This dialog allows to detect and connect a UPP with option UPP-B8 on the LAN, to be used as playback system for the background noise generation.

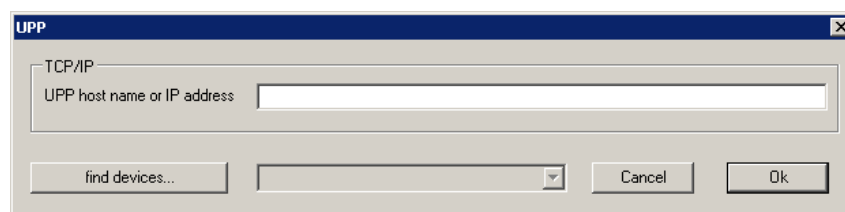

Fig. 43 Window for connecting to a UPP on the LAN

A click on the "find devices..." button searches the local area network for audio analyzers and fills the combobox next to the button with the computer names and IP addresses of the found devices. Select the appropriate instrument in the combobox and click "Ok".

To establish a remote control connection between UPV and UPP do the following:

1. Once the “LAN” LED on the UPP is on, press button “CASCADE / LAN RESET” once and wait until the “CASCADE” LED is blinking.
2. Press the “CASCADE / LAN RESET” button again.
3. Click the “Find” button in the UPP remote control window on the UPV.
4. Now the computer name on the UPP appears in the UPP remote control window. Select it and close the window with “Ok”.

Input Switcher

“Input Switcher” allows configuring the use of an R&S UPZ input switcher connected to the R&S UPV RS-232 port, to switch analyzer input 2 between sending tests and binaural receiving tests.

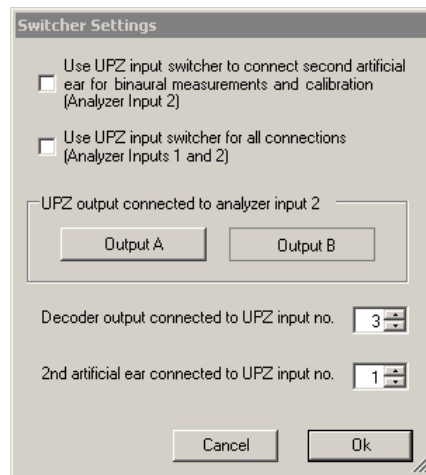

Fig. 44 Switcher window

If only the first tick box is activated, the switcher is only used to switch the second analyser input between decoder output and second artificial ear. In this case the channel assignments in the “Switcher Settings” window are applied.

If the second tick box is activated, the switcher is used for all signal sources and both UPV analyser inputs.

The following table shows the assignment of the signal sources to the switcher channels when the second tick box is activated.

Channel	Signal Source
1	Second (left) artificial ear
2	First (right) artificial ear
3	Decoder output
4	Free field microphone
5	Diffuse field microphone
6	UPP-B8 output channel 10

Table 4 Input switcher channel assignment

Connect switcher output A to UPV analyser input 1 and switcher output B to UPV analyser input 2.

Report settings

“Report settings” allows defining the type of information which should appear in the reports. For details on reporting, see section 8 below.

Generate temporary export files

If “Generate temporary export files” is checked, some of the measurement macros create “result.exp” with result value and verdict, and, if applicable, “curve.exp” or “abscurve.exp” and “relcurve.exp” files with curve data in ASCII format. This function is provided for compatibility with R&S UPL-B9.

Generate temporary image files

Item “Generate temporary image files” causes the measurement macros to store a screenshot of the measurement window after completion of the test to a file “Image.TIF” for use by a remote controlling host.

Store results of further measurements

If “Store results of further measurements” is checked, curves and calculated values like loudness ratings are also stored for additional measurements started with the “Add Measurement” key. They will appear in reports of the respective measurements.

Do not change scale for further meas.

Menu item “Do not change scale for further meas.” deactivates the automatic Y-axis scaling if the curve of an additional measurement leaves the plot area partially or totally.

Store loaded curve data to results

If “Store loaded curve data to results” is checked, curves loaded from file with the “Load Curve” softkey are stored to the results database and will appear in reports of the respective measurements.

Enable remote control

Menu item “Enable remote control” activates the interface of the program for remote control using the client “ControlK9.exe”.

4 Calibration

Calibration Devices

R&S UPV-K9 allows to simultaneously storing calibration values for multiple individuals of the same type. This allows switching devices without the requirement for re-calibration. However, regular re-calibration is recommended in order to assure the correct function of the used devices.

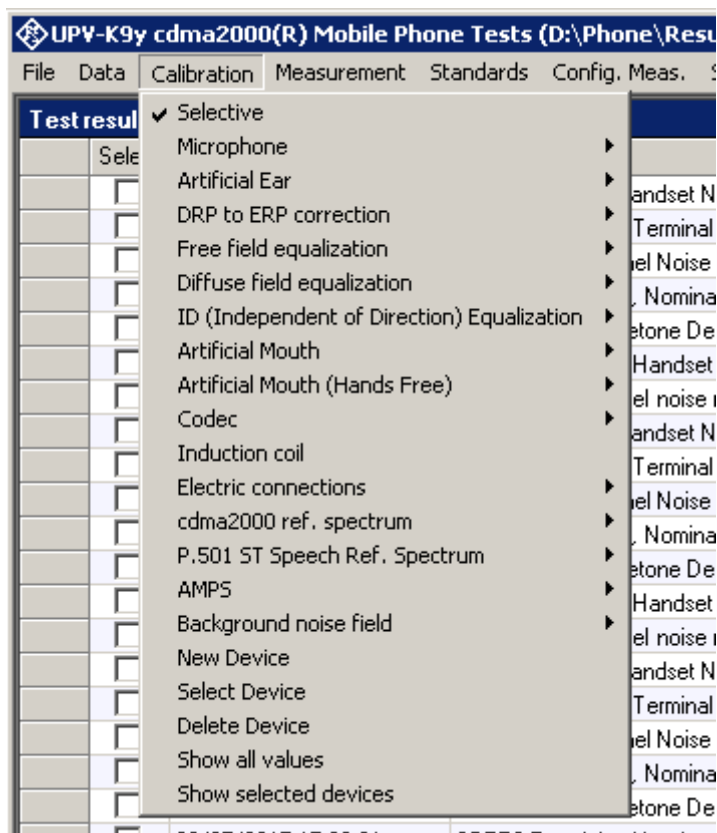

Fig. 45 Calibration menu

For every device to be calibrated, an entry must be created using “Calibration → New device” in the main menu. This menu item opens an entry window to specify the calibrated device. A category of device must be chosen from the combo box on top. Type, manufacturer and serial number are entered into the text boxes below. The entries are confirmed by clicking on the “Save and close” button.



Fig. 46 Input window for information about calibrated device

Before a device can be calibrated or used, it must be selected with “Calibration → Select device” in the main menu. Clicking on this item opens a window with a table of all entered devices.

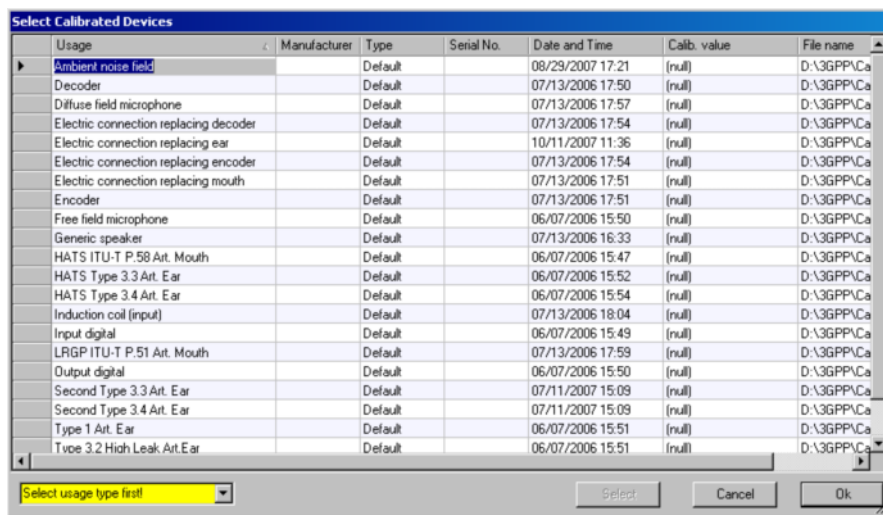

Fig. 47 Window for selection of calibrated devices

In the combo box lower left, a category of devices must be selected. Subsequently the table is reduced to available devices in this category. At first startup, there is only a “Default” device for each category, but when more devices have been created with the “New device” function, a choice will be available in this view. In this state a row in the table can be marked with a mouse click on its left end. A mouse click on the button “Select” selects this device for the associated usage.

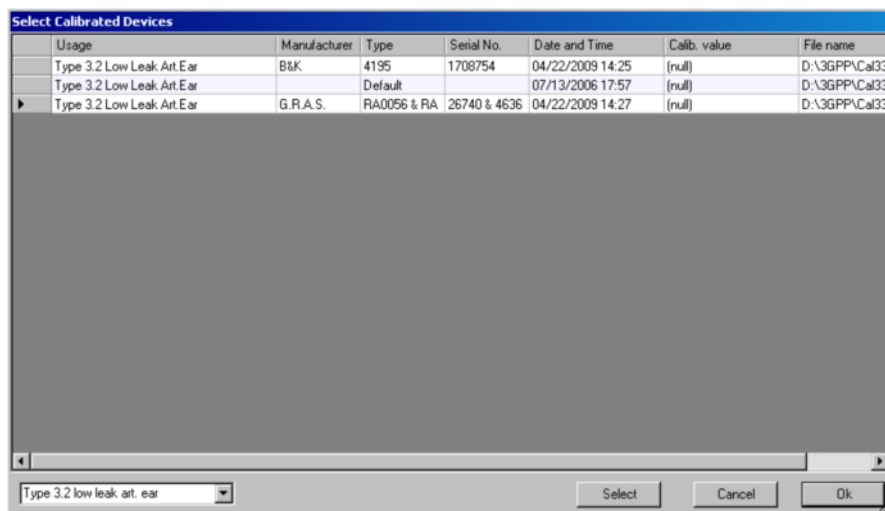

Fig. 48 Selection window for particular device type

Subsequently this procedure may be repeated for other categories. Finally all selections are confirmed by clicking the “Ok” button.

All calibration data are stored on the R&S UPV hard disk and are therefore automatically available again after every restart. The calibration values for the R&S UPV-K9 option are stored independently of other options.

All calibration routines below require as pre-requisite that a device for the respective usage has been generated and selected.

To simplify the procedure for the case that it is not intended to use multiple devices of the same category or to include information about the used devices into a report, there is a “Default” device selected for each device type or category after the first start of the program.

An overview all selected calibration devices together with the calibration values is given under the menu item “Calibration → Show selected devices”.

Microphone Calibration

- **Insert the measuring microphone fully into the adapter of the sound level calibrator and switch on the calibrator.**

Note: *After inserting the microphone, wait about 10 s to allow for static pressure equalization.*

- **Call the test routine with “Calibration → Microphone → Free field” or “Calibration → Microphone → Diffuse field” from the main menu, depending on the microphone.**

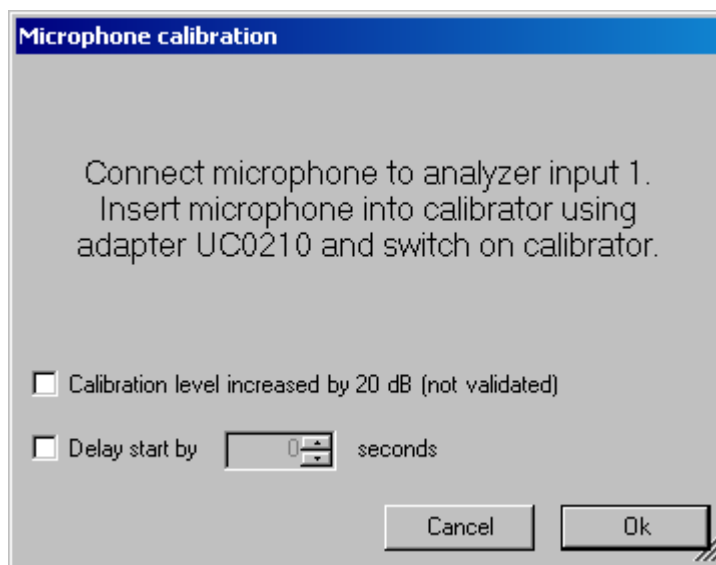

Fig. 49 Initial window of microphone calibration

For calibrators providing a sound pressure level of 114 dB (10 Pa), the checkbox “Calibration level increased by 20 dB” must be checked. In all other cases the checkbox must remain unchecked!

The output voltage of the microphone is measured and the sensitivity displayed with reference to 1 Pa. If a mere power supply without gain is used, the displayed sensitivity must approximately match the value in the calibration certificate of the microphone capsule (typical value for microphone capsule 4134 of artificial ear 4185 is approx. 12 mV/Pa, display = 120 mV/Pa). If a conditioning amplifier with 20 dB gain (recommended value) is used, the displayed sensitivity must be about 10 times higher. If the voltage measured is below 3 mV, an error message is displayed. Possible error sources are, for example, a switched-off microphone power supply or a disabled calibrator. In this case, the program requests that the test be repeated. After switching on the microphone power supply, wait approx. 20 s before restarting the measurement with the “Ok” button.

Calibration of Artificial Ear

Prior to the measurements, the absolute sensitivity of the microphone in the artificial ear must be determined using a sound level calibrator such as the Brüel & Kjær 4231 with a sound pressure level of 94 dB SPL or a sound pressure of 1 Pa at 1 kHz.

Calibration of Ear Type 1

Note: *The use of artificial ear type 1 is not foreseen in TIA-1042. However, R&S UPV-K9 offers the use of this device regardless whether it is supported by the particular standard applied.*

➤ Switch off the microphone power supply.

Note: *The 200 V polarization voltage of the microphone may cause a slight electric shock. The current is harmless, but the microphone preamplifier may be damaged.*

- **Remove the microphone from the artificial ear.**
- **Screw back the microphone capsule and switch on the operating voltage.**
- **Insert the microphone fully into the adapter of the sound level calibrator and switch on the calibrator.**

Note: *After inserting the microphone wait about 10 s to allow for static pressure compensation.*

- **Select “Calibration → Artificial ear → Type 1” from the main menu.**

For calibrators providing a sound pressure level of 114 dB (10 Pa), the checkbox “Calibration level increased by 20 dB” must be checked. In all other cases the checkbox must remain unchecked!

The output voltage of the microphone is measured and the sensitivity displayed with reference to 1 Pa. If a mere power supply without gain is used, the displayed sensitivity must approximately match the value in the calibration certificate of the microphone capsule (typical value for microphone capsule 4134 of artificial ear 4185 is approx. 12 mV/Pa, display = 120 mV/Pa). If a conditioning amplifier with 20 dB gain (recommended value) is used, the displayed sensitivity must be about 10 times higher. If the voltage measured is below 3 mV or fluctuating by more than 0.2 dB, an error message is displayed. Possible error sources are, for example, a switched-off microphone power supply or a disabled calibrator. In this case, the program requests that the test be repeated. After switching on the microphone power supply, wait approx. 20 s before restarting the measurement.

The reference value measured is stored in a file on the hard disk and used for all subsequent measurements when the same artificial ear type 1 is used as currently selected.

Calibration of Ear Type 3.2 Low Leakage

- **Connect the sound level calibrator tightly to the artificial ear using the adapter DP0939 and switch on the calibrator.**
- **Select “Calibration → Artificial ear → Type 3.2 Low Leak” from the main menu.**

For calibrators providing a sound pressure level of 114 dB (10 Pa), the checkbox “Calibration level increased by 20 dB” must be checked. In all other cases the checkbox must remain unchecked!

The output voltage of the microphone in the ear is measured and the sensitivity displayed with reference to 1 Pa. If the voltage measured is below 3 mV or fluctuating by more than 0.2 dB, an error message is displayed. Possible error sources are, for example, a switched-off microphone power supply or a disabled calibrator. In this case, the program requests that the test be repeated. After switching on the microphone power supply, wait approx. 20 s before restarting the measurement.

The measured reference value is stored in a file on the hard disk and used for all subsequent measurements when the same ear type 3.2L is used as currently selected.

Reading the Calibration Data of Ear Type 3.2 LL

The frequency response of the artificial ear of type 3.2L is supplied on a floppy together with the artificial ear. The data is used for transforming the measurement values from the drum reference point to the ear reference point.

- Connect a USB floppy disk drive with the calibration disk to the R&S UPV, copy the file "OES_LL.ADA" from the manufacturer's calibration disk to a USB stick or a CD-ROM or make this file available on a network drive via LAN.
- Call the routine "Calibration → DRP to ERP Correction → Type 3.2 Low leak". Browse to the file "OES_LL.ADA" and click "Open".

The calibration file is read. The modified data is stored on the R&S UPV hard disk. This procedure needs only be repeated after a change of the calibration data, e.g. after a recalibration of the ear by the manufacturer, or when the "Phone" directory has been renamed or removed.

Calibration of Ear Type 3.2 High Leakage

- **Connect the sound level calibrator tightly to the artificial ear using the adapter DP0939 and switch on the calibrator.**
- **Select "Calibration → Artificial ear → Type 3.2 High Leak" from the main menu.**

For calibrators providing a sound pressure level of 114 dB (10 Pa), the checkbox "Calibration level increased by 20 dB" must be checked. In all other cases the checkbox must remain unchecked!

The output voltage of the microphone in the ear is measured and the sensitivity displayed with reference to 1 Pa. If the voltage measured is below 3 mV or fluctuating by more than 0.2 dB, an error message is displayed. Possible error sources are, for example, a switched-off microphone power supply or a disabled calibrator. In this case, the program requests that the test be repeated. After switching on the microphone power supply, wait approx. 20 s before restarting the measurement.

The measured reference value is stored in a file on the hard disk and used for all subsequent measurements when the same ear type 3.2H is used as currently selected.

Reading the Calibration Data of Ear Type 3.2 HL

The frequency response of the artificial ear of type 3.2H is supplied on a floppy together with the artificial ear. The data is used for transforming the measurement values from the drum reference point to the ear reference point.

- Connect a USB floppy disk drive with the calibration disk to the R&S UPV, copy the file "OES_HL.ADA" from the manufacturer's calibration disk to a USB stick or a CD-ROM or make this file available on a network drive via LAN.
- Call the routine "Calibration → DRP to ERP Correction → Type 3.2 High leak". Browse to the file "OES_HL.ADA" and click "Open".

The calibration file is read. The modified data is stored on the R&S UPV hard disk. This procedure needs only be repeated after a change of the calibration data, e.g. after a recalibration of the ear by the manufacturer, or when the "Phone" directory has been renamed or removed.

Calibration of Ear Type 3.3

- Connect the sound level calibrator tightly to the artificial ear using the adapter UA-1546 and switch the calibrator on.
- Select “Calibration → Artificial ear → HATS Type 3.3” from the main menu.

For calibrators providing a sound pressure level of 114 dB (10 Pa), the checkbox “Calibration level increased by 20 dB” must be checked. In all other cases the checkbox must remain unchecked!

The type 3.3 ear calibration requires the calibrator with adapter UA-1546 to be held manually against the ear. If the HATS is installed remote from the R&S UPV, the checkbox “Delay start by ... seconds” can be checked and a time interval can be entered by which the start of the calibration measurement is delayed. The countdown is displayed on the R&S UPV screen.

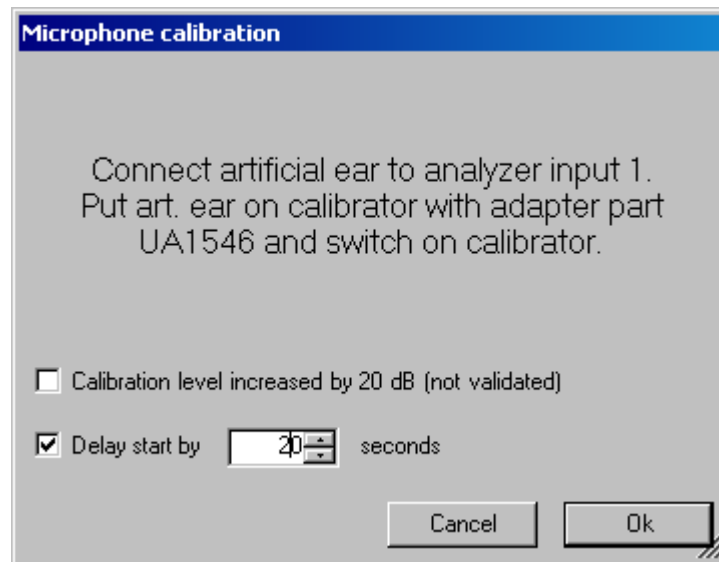

Fig. 50 Ear calibration window with delayed start

The output voltage of the microphone in the ear is measured and the sensitivity displayed with reference to 1 Pa. If the voltage measured is below 3 mV or fluctuating by more than 0.2 dB, an error message is displayed. Possible error sources are, for example, a switched-off microphone power supply or a disabled calibrator. In this case, the program requests that the test be repeated. After switching on the microphone power supply, wait approx. 20 s before restarting the measurement.

The measured reference value is stored in a file on the hard disk and used for all subsequent measurements when the same ear type 3.2L is used as currently selected.

Reading the DRP-ERP Correction Data of Ear Type 3.3

Call the routine “Calibration → DRP to ERP Correction → Type 3.3 → From ITU-T P.57 Table 2b”. This procedure needs only be repeated when the “Phone” directory has been renamed or removed.

Alternatively it is also possible to load individual DRP-ERP correction data from a calibration disk. This option is not conformant with the standards.

Reading the Diffuse Field Equalization Data of Ear Type 3.3

3GPP C.S0056-A (TIA1042-A), diffuse field equalization is applied to receiving frequency response results with handset and headset UEs. Call the routine "Calibration → Diffuse field equalization → Type 3.3 → From ITU-T P.58 Table 3". This procedure needs only be repeated when the "Phone" directory has been renamed or removed.

Alternatively it is also possible to load individual diffuse field equalization data from a calibration disk. This option is not conformant with the standards.

Calibration of Ear Type 3.4

- **Remove the pinna and the ear canal simulator, connect the sound level calibrator tightly to the artificial ear using the short steel adapter and switch the calibrator on.**
- **Select "Calibration → Artificial ear → HATS Type 3.4" from the main menu.**

For Head Acoustics HMS II, calibrator B&K 4231 must be used in conjunction with the short steel calibration adapter.

For calibrators providing a sound pressure level of 114 dB (10 Pa), the checkbox "Calibration level increased by 20 dB" must be checked. In all other cases the checkbox must remain unchecked!

The output voltage of the microphone in the ear is measured and the sensitivity displayed with reference to 1 Pa. If the voltage measured is below 3 mV or fluctuating by more than 0.2 dB, an error message is displayed. Possible error sources are, for example, a switched-off microphone power supply or a disabled calibrator. In this case, the program requests that the test be repeated. After switching on the microphone power supply, wait approx. 20 s before restarting the measurement.

The measured reference value is stored in a file on the hard disk and used for all subsequent measurements when the same ear type 3.4 is used as currently selected.

Reading the DRP-ERP Correction Data of Ear Type 3.4

Call the routine "Calibration → DRP to ERP Correction → Type 3.4 → From ITU-T P.57 Table 2b". This procedure needs only be repeated when the "Phone" directory has been renamed or removed.

Alternatively it is also possible to load individual DRP-ERP correction data from a calibration disk. This option is not conformant with the standards.

Reading the Diffuse Field Equalization Data of Ear Type 3.4

From Release 10 of 3GPP TS 26.132, diffuse field equalization is applied to receiving frequency response results with handset and headset UEs. Call the routine "Calibration → Diffuse field equalization → Type 3.4 → From ITU-T P.58 Table 3". This procedure needs only be repeated when the "Phone" directory has been renamed or removed.

Alternatively it is also possible to load individual diffuse field equalization data from a calibration disk. This option is not conformant with the standards.

Calibration of Artificial Mouth for Handset Tests

Before a mobile phone can be tested, the absolute sensitivity and frequency response of the artificial mouth have to be measured and corrected with the aid of a previously calibrated pressure-field microphone. The measuring microphone removed from artificial ear type 1 can be used for this purpose or an additional microphone capsule is screwed to the microphone preamplifier. The standard microphone is used as a reference for determining the frequency response of the mouth. The frequency response of the microphone can be ignored in the test frequency range (100 Hz to 8 kHz) (see also calibration certificate of microphone capsule).

Since interfering sound falsifies the corrections, the artificial mouth must be calibrated in the sound-proof test chamber.

First of all, the measuring microphone has to be calibrated.

- **Select a reference microphone type with “Calibration → Artificial mouth → Select reference mic”.**

For the selected microphone type, a device must be selected and calibrated (see above). This device must be connected to R&S UPV analyzer input 1 via power supply/conditioning amplifier.

If the selected reference microphone is a diffuse field or pressure field type (e.g. B&K 4131 or 4134) or a microphone from a Type1 artificial ear, fit the microphone at right angles to the mouth at the mouth reference point (MRP) using the gauge supplied with the mouth (positioning at right angles is necessary because diffuse field or pressure-calibrated microphones have a flat frequency response to sound from random incident direction and therefore exhibit an emphasis on high frequencies with frontal sound incidence).

If the selected microphone is a free field microphone, it must be mounted in the axis of the sound outlet of the artificial mouth.

- **Call the calibration routine with “Calibration → Artificial mouth → LRGP ITU-T P.51” or “Calibration → Artificial mouth → HATS ITU-T P.58” from the main menu.**

The sound pressure generated at the MRP is set to exactly -4.7 dBPa in an automatic measurement routine at 1 kHz. The generator voltage required is stored in a file on the hard disk and used as a reference for all subsequent settings with the same artificial mouth. If the sound pressure cannot be adjusted to -4.7 dBPa, an error message is displayed with a request to check the connection of the artificial mouth and to repeat the measurement. A possible error source would be that the transformer supplied is not connected between the generator and the artificial mouth.

The uncorrected frequency response of the artificial mouth is measured and displayed. Next, the frequency response is measured with the inverse frequency response correction automatically selected in the generator (equalization). Residual errors caused by nonlinearities of the speaker in the mouth are measured and taken into account in the final equalization file as fine correction.

To verify the results, the absolute sound pressure versus frequency is

measured at a sound pressure of 4.7 dBPa (reference value for most of the measurements). The absolute sound pressure at each frequency must be within a tolerance band of ± 0.2 dB. Correct calibration without interfering sound yields an almost straight line in the middle between the two limit lines.

Before sending tests can be performed, a reference spectrum calibration of the sending signal at the Mouth Reference Point is required which equalizes the speech signal “Normal” according to the measured frequency response of the artificial mouth and measures the resulting acoustic spectrum at the MRP.

Speech Spectrum Calibration

For tests using speech signal “Normal” or natural voice according to ITU-T P.501 as test signal, the spectrum of the test signal has to be measured and stored as reference spectrum for the transfer function (gain) calculation. For sending and sidetone tests, the signal has to be filtered in addition with the inverse frequency response of the artificial mouth. A calibrated reference microphone must be placed at the Mouth Reference Point (MRP) for this purpose. It is recommended to perform the reference spectrum calibration directly after the mouth calibration, using sub-menu item “Calibration → Artificial Mouth → ... → With cdma2000 Ref. Spectrum” or “Calibration → Artificial Mouth → ... → With P.501 Ref. Spectrum”, respectively.

The reference spectrum calibration for the receiving direction does not require external equipment or wiring. The reference signal at the output from the R&S UPV generator to the speech input of the system simulator is measured via internal connection to the R&S UPV analyzer input. For narrow-band tests in receiving direction, a band-limited version of the test signal is used. Each version of the test signal has to be calibrated separately.

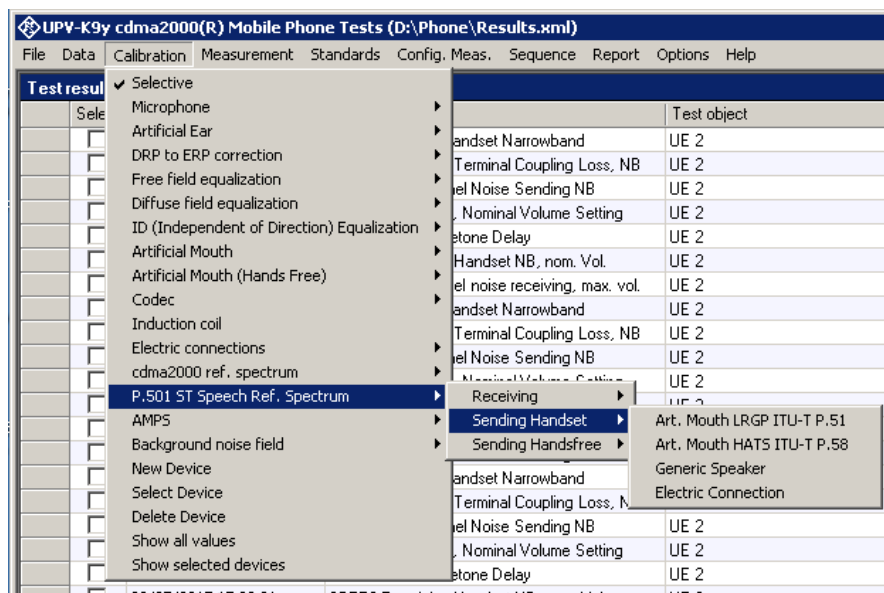

Fig. 51 Submenu for reference speech spectrum calibration

Calibration of CMU Speech Codec

The calibration of the speech coder and decoder is necessary to be able to calculate absolute loudness. Calibration has to be performed only once and must be repeated only if the CMU used is replaced.

Note that encoder and decoder are handled as separate devices but calibrated with one routine.

Auxiliary settings required for calibration can be found in the CMU under "Service Cfg.". Call the calibration routines with "Calibration → Codec" from the main menu.

The following information is displayed:

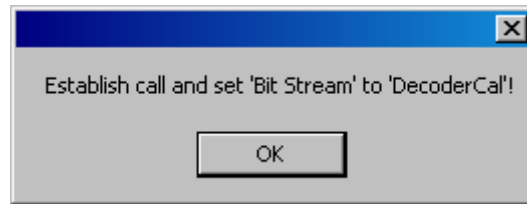

Fig. 52 Message box during decoder calibration

Set up a call to the mobile phone. Set bit stream or voice setting on the CMU to "Decoder Cal" and then click the "OK" button.

The actual voltage at the decoder output of the CMU is now measured for a digital full-scale signal and the required correction value is calculated and saved in the R&S UPV. The following request is then displayed:

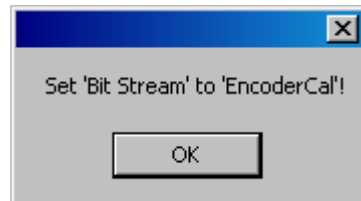

Fig. 53 Message box during encoder calibration

After the "OK" button has been clicked, the input sensitivity of the speech coder is measured and the input voltage required for digital full scale is measured at the speech coder and saved in the R&S UPV.

Calibration of CMW Speech Codec

The CMW500 does not provide the "Decoder Cal" and "Encoder Cal" functionalities. Instead the maximum peak input and output voltage can be set in the user interface.

Speech Analysis	
Routing	AF-1
Signaling	No Connection
Control	
Input Level Full-Scale (Peak)	0.100 V
Output Level Full-Scale (Peak)	0.300 V

Fig. 54 Setting of the full-scale peak input and output values in the CMW user interface

“Calibration → Codec → CMW” opens windows where these values can be entered in unit mV in the mobile phone test program.

Calibration of Noise Field for “Speech Quality in Presence of Background Noise” Test

Connections

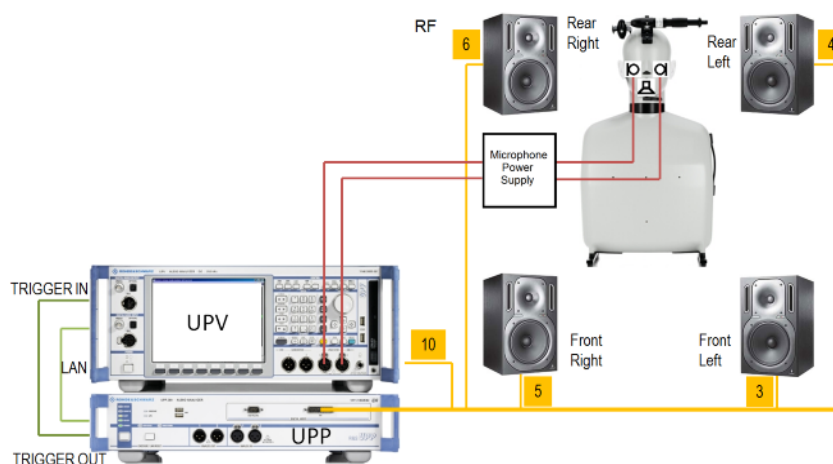

Fig. 55 Test setup and connection of external components for the adjustment of the background noise field.

Connect

1. LAN socket of UPV to LAN socket of UPP
2. UPP trigger output to UPV trigger input
3. UPP-Z8A output 3 to input of front left active speaker
4. UPP-Z8A output 4 to input of rear left active speaker
5. UPP-Z8A output 5 to input of front right active speaker
6. UPP-Z8A output 6 to input of rear right active speaker
7. UPP-Z8A configured subwoofer output (by default 7) to input of active subwoofer
8. Right artificial ear to UPV analyzer input 1 via microphone power supply
9. Left artificial ear to UPV analyzer input 2 via microphone power supply

For the delay measurements, the operator will be prompted to modify the input connections: a connection has to be made from UPP-Z8A output 10 to UPV input 1, and both artificial ears have to be connected subsequently to UPV analyzer input 2.

Optionally a UPZ input switcher can be used (see chapter 'Switcher Support').

Establishing the remote control connection between UPV and UPP

After power up of both instruments and the interconnection with a LAN switch cable, first an IP connection has to be established between UPV and UPP.

1. Start the UPV-K9x program and open window "Options → UPP remote control".
2. Once the "LAN" LED on the UPP is on, press button "CASCADE / LAN RESET" once and wait until the "CASCADE" LED is blinking.
3. Press the "CASCADE / LAN RESET" button again.
4. Click the "Find" button in the UPP remote control window on the UPV.
5. Now the computer name on the UPP appears in the UPP remote control window. Select it and close the window with "Ok".

Prerequisites

The calibration of both artificial ears of the HATS is required for performing the calibration of the background noise field.

Switcher Support

If "Input Switcher UPZ" is enabled in "Noise Calibration Configuration", the calibration process will try to connect all required signal sources automatically to UPV input instead of prompting the operator to change cabling. This presumes:

- UPV is connected to UPZ via serial cable (RS232) **OR** USB cable (do not connect USB if you want to use RS232!);
- USB-to-serial device driver is installed (only if using USB connection);
- UPZ is powered ON (green 'ON'-LED on switcher front panel)

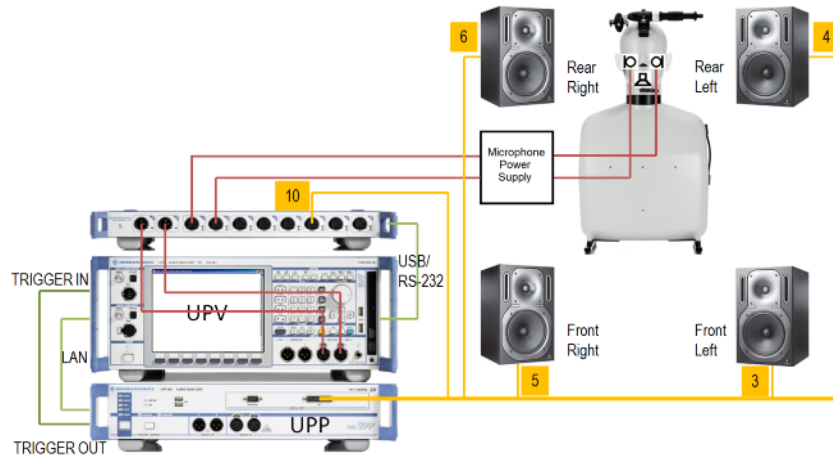

Fig. 56 Test setup and connection of external components with input switcher UPZ for the adjustment of the background noise field.

When starting the calibration process, a dialogue is displayed to instruct the operator how to connect the input switcher's analogue input and output connections. The connections to UPZ input channel 3, 4 and 5 are not necessary for the calibration, but will be needed for later measurement (note: only 1 microphone need to be connected to input channel 4 or 5, respectively).

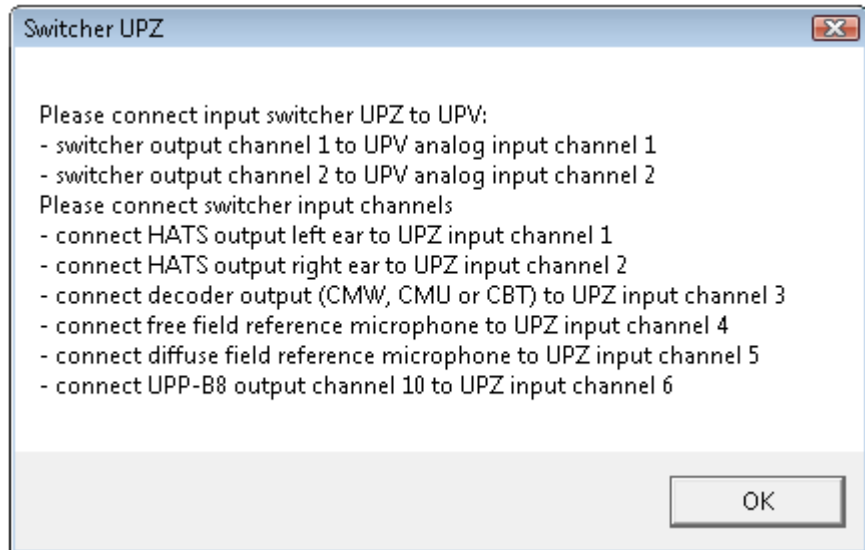

Fig. 57 Switcher support, analogue connection instructions.

or – if switcher could not be detected – how to establish the control connection from UPV to UPZ:

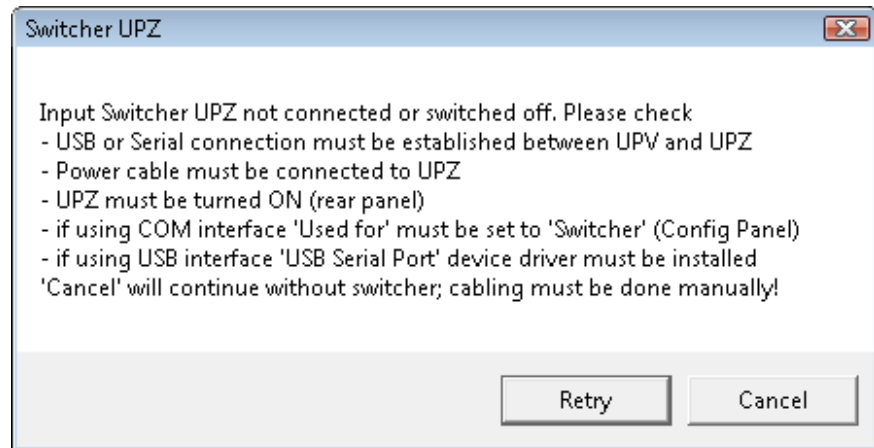

Fig. 58 Switcher support, control connection instructions.

If the switcher cannot be enabled at this point, "Cancel" will disable switcher for the current calibration. The cabling has to be done manually. The corresponding setting in configuration window will not be changed. On next start of calibration it will again be attempted to use the switcher.

The calibration process checks the connection to UPZ whenever the switcher needs to be operated. If switcher control fails while calibration is running (e.g. by unplugging the control or power cable), the user will be prompted to establish the analogue connections manually. This allows the calibration to terminate correctly:

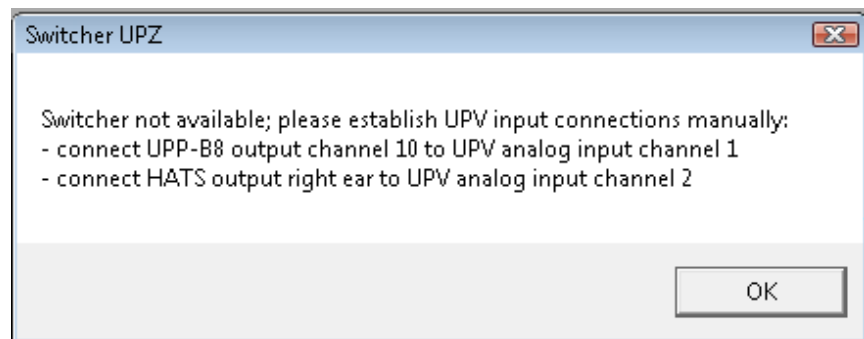

Fig. 59 Switcher support, error message if switcher failed during calibration.

Starting the calibration process

Before calibration can be started user has to select the reference microphone:

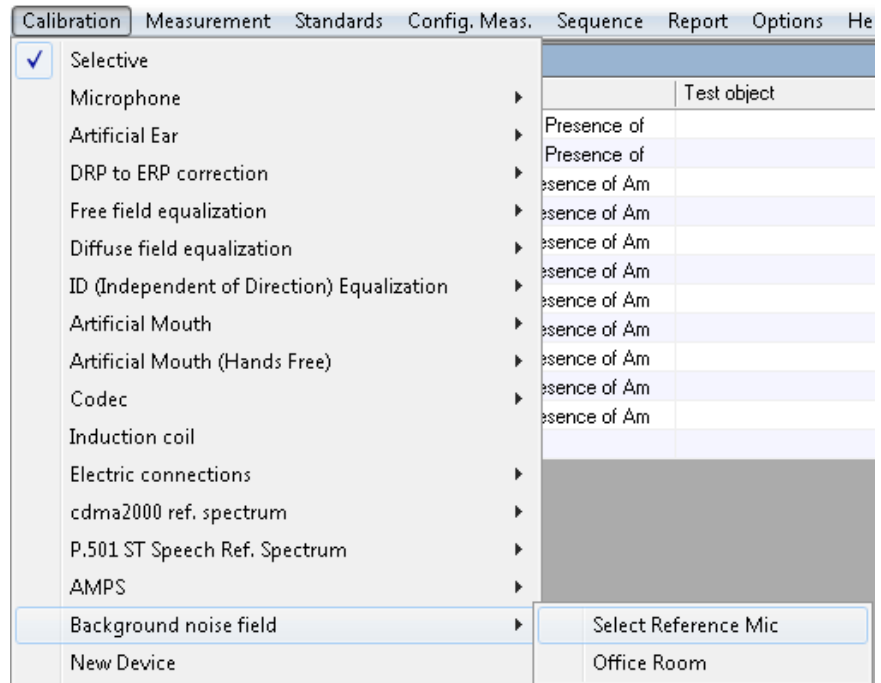

Fig. 60 Selecting the reference microphone for the background noise calibration process.

Calibration is started by selecting the 'Office Room':

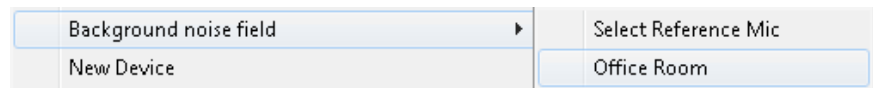

Fig. 61 Starting the background noise calibration process.

A brief set of cabling instructions appears first of all:

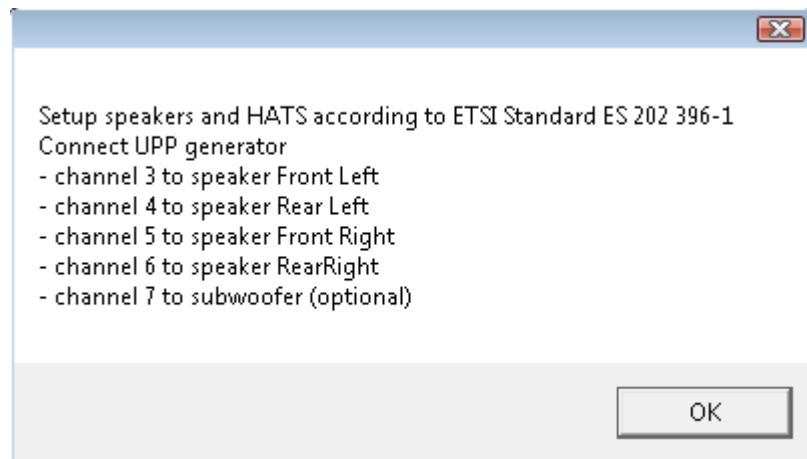

Fig. 62 Cabling instructions for the speakers.

Stopping and resuming the calibration process

The calibration process can be stopped at any time. All of the calibration data recorded up to this point are then available and can be viewed in the report.

To abort a running calibration (e.g. to improve the loudspeaker positions) is possible in the following ways:

- If a dialog box appears, click the "Abort" or "Cancel" button

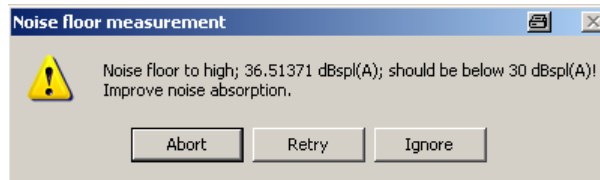

Fig. 63 Dialogue with 'Abort' button to abort calibration.

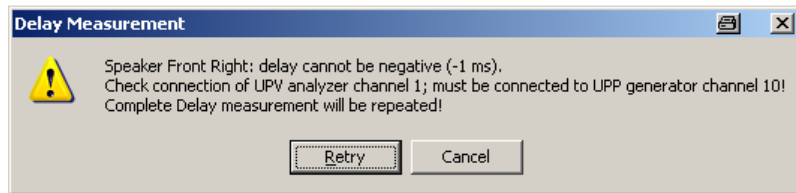

Fig. 64 Dialogue with 'Cancel' button to abort calibration.

- If measurement is running, click the "Cancel" button and confirm with 'Break':

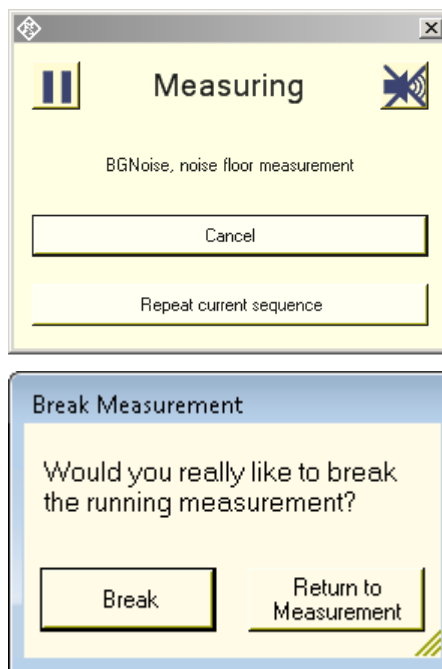

Fig. 65 Window during running measurement and 'Cancel' confirmation dialogue.

After calibration has been stopped, a dialog box informs the operator about the calibration section that was aborted.

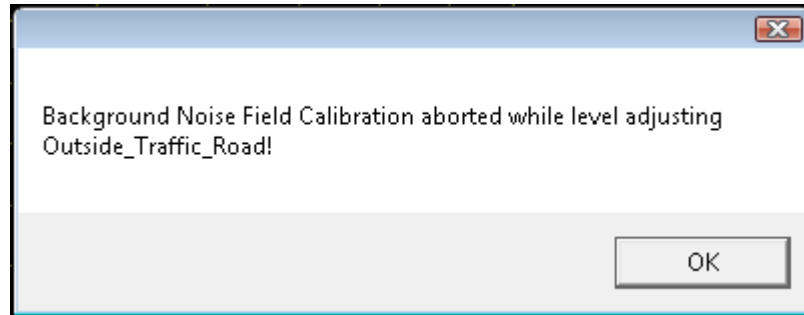

Fig. 66 'Calibration aborted' message, e.g. when level adjusting Outside_Traffic_Road.

A calibration that had been aborted can be resumed at certain resuming points. When restarting a calibration that partly had been finished the calibration process will prompt the user at every resuming point

- to resume the calibration at this point (recalibrate this and the following)
- to skip this calibration section
- to abort the calibration

By skipping all successfully terminated calibration sections, the calibration process will be resumed at the beginning of the section where it had been aborted. For details please see chapter 'Calibration Sections and Resuming Points'.

Preparatory Measurements for Delay Measurement

Before the delay measurement is performed, additional plausibility checks are carried out at each speaker to ensure that the wiring is correct and that the sound pressure level is high enough.

Measurement of Sound Pressure

The unweighted sound pressure level should reach at least 80 dBspl (or the value selected as 'Min sound pressure level' in configuration window, if modified) at normal drive level.

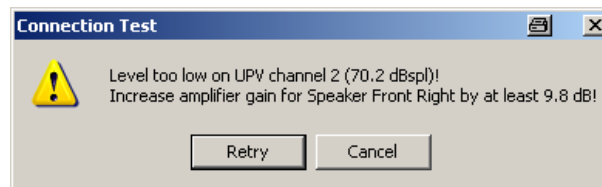

Fig. 67 Message for insufficient level.

If this sound pressure is not reached, an error message appears which cannot be ignored. After the gain factor of the external amplifier or active speaker has been increased, the measurement can be repeated (by selecting 'Retry').

Measurement of Level Change at Microphone Amplifier Output

During this measurement 2 different levels are successively applied to each speaker. The output at the microphone amplifier (measured by UPV input channel 2) is expected to change by the same amount (5 dB).

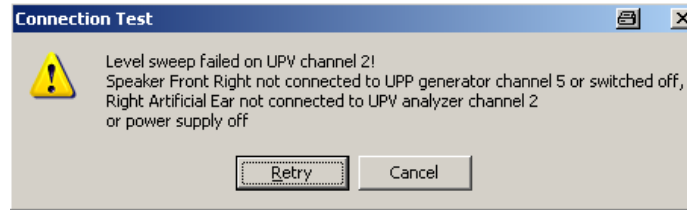

Fig. 68 Message for insufficient sound pressure level increase.

If the amplifier output does not change with the UPP output level, this may have the following causes:

- the microphone amplifier is switched off
- the HATS ear is not connected to the correct amplifier channel
- the microphone amplifier is not connected or is incorrectly connected to UPV input channel 2
- the desired speaker is switched off
- the desired speaker is not connected to the correct UPP output channel
- the requested sound pressure level cannot be output by the speaker (speaker gain too high or 'Maximum output level' too high),

After the error has been rectified, the measurement can be repeated by selecting 'Retry'. If the configuration has to be changed, the calibration must be aborted ('Cancel' button).

Measurement of Level Change at Reference Input

During this measurement 2 different levels are successively applied to UPP output channel 10. The input level at UPV input channel 1 is expected to change by the same amount (5 dB).

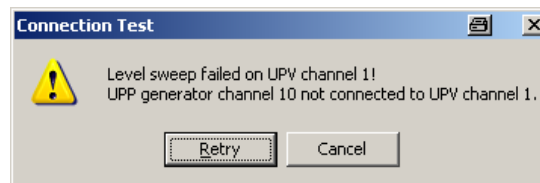

Fig. 69 Message for insufficient level change at reference input.

If the reference input does not change with the UPP output level, there is no connection between UPV channel 1 and UPP output channel 10.

After the error has been rectified, the measurement can be repeated by selecting 'Retry'.

Delay Measurement

The delay measurement determines the time it takes for the sound to travel from the speaker membranes to the left and right ear of the HATS. The travel time and therefore the distance of the full-range speakers from the HATS is measured by means of cross-correlation of the acoustic (sound pressure) signal and the electrical reference signal.

Since the delay measurement is quite complicated owing to the required cabling modifications, it can be skipped if a valid delay calibration is already available and if the speaker layout and the HATS position have not been

changed in the meantime. The latter is not recognizable by the calibration process; it is therefore the responsibility of the user to repeat the delay calibration if necessary.

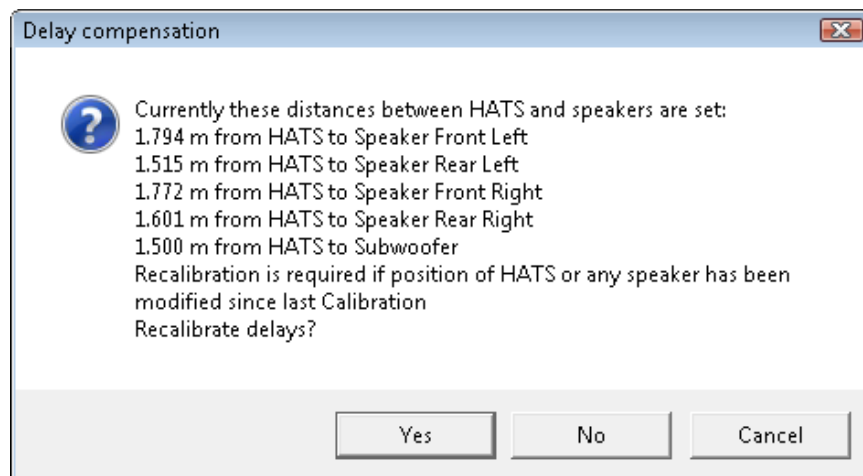

Fig. 70 Message querying the start of the delay calibration.

To perform the delay measurement, the reference signal from channel 10 of the UPP generator is connected to analyzer channel 1 of the UPV, and the signal from the respective ear is connected to analyzer channel 2 (via a preamplifier). Dialog boxes show which ear is currently being measured and therefore must be connected (to UPV input channel 2. If the R&S input switcher UPZ is used, the connection will be switched automatically without any user interaction.

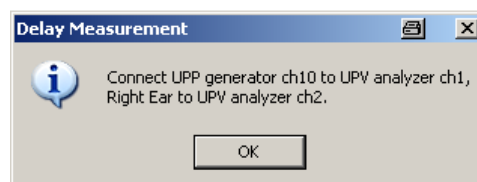

Fig. 71 Instruction for connections during delay measurement.

This box must be confirmed after reconnection of the UPV analyzer; then the measurement and the generator signal are started.

Connection problems can be determined from the measured value obtained during the delay measurement:

- Checking of the delay differences between the measurement channel and reference channel

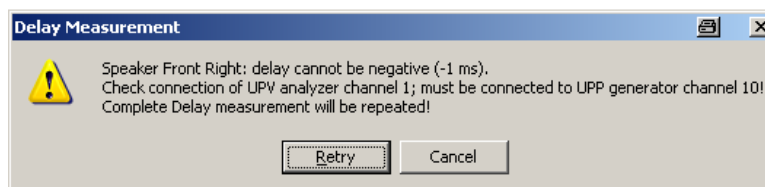

Fig. 72 Plausibility check for the delay result.

If the reference channel has a greater delay than the measurement channel, it is not connected to the reference signal but instead to the 2nd channel of the microphone amplifier.

- Distance between the speaker and associated HATS ear is too large



Fig. 73 Message for unexpectedly long delay.

If the measured distance is greater than the expected maximum distance, the longer indirect sound path to the ear located opposite may possibly have been measured. In this way it is possible to detect inadvertent swapping of the HATS ears. The 'Max distance HATS to speaker' can be adjusted in the configuration window after cancelling the calibration.

- Distance between the speaker and associated HATS ear is too small

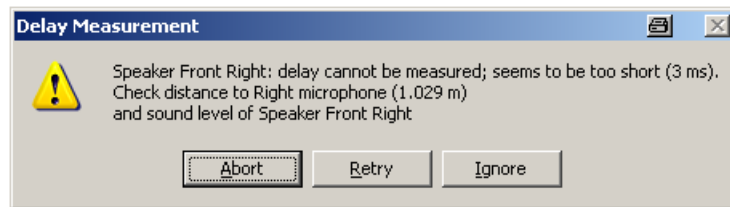

Fig. 74 Message for unexpectedly short delay.

If the distance is less than the intended minimum distance, the speaker is too close to the HATS. This warning can be ignored, if the measured distance matches the actual position of the speaker. The 'Min distance HATS to speaker' can be adjusted in the configuration window after cancelling the calibration.

The measurement can be repeated after the cabling or the amplifier level has been corrected.

If the R&S Input switcher UPZ is used, the connections are automatically switched without any user interaction. Otherwise the cabling must be changed during and after the delay measurement; the user is instructed to do this in dialog boxes.



Fig. 75 Instructions for change of cabling during the calibration process.

The distance between HATS and subwoofer cannot be measured but must be entered manually. This value is not critical for the measurement and can be given with an accuracy of 10 cm.

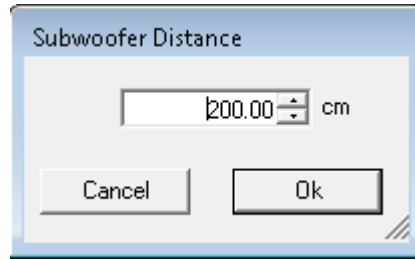

Fig. 76 Delay measurement, manual entry of subwoofer distance.

After completion of the delay measurement, it is thus ensured that the HATS ears are correctly cabled and the output level is high enough. A list showing all of the determined distances is displayed before the actual equalization begins.

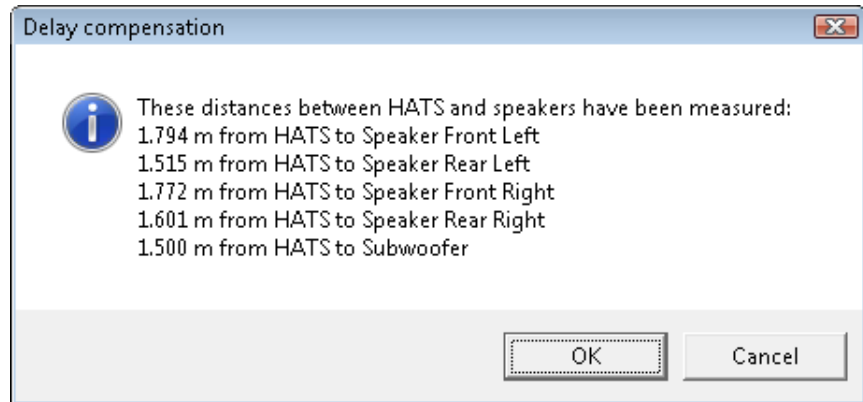

Fig. 77 List of determined distances.

Preparatory Measurements for Equalization

Equalization can only be performed successfully if the room acoustics meet certain requirements.

Noise Floor

The acceptable noise floor is max. 30 dB(A)spl. If it is above this value, equalization may fail in the case of weak noise fields.

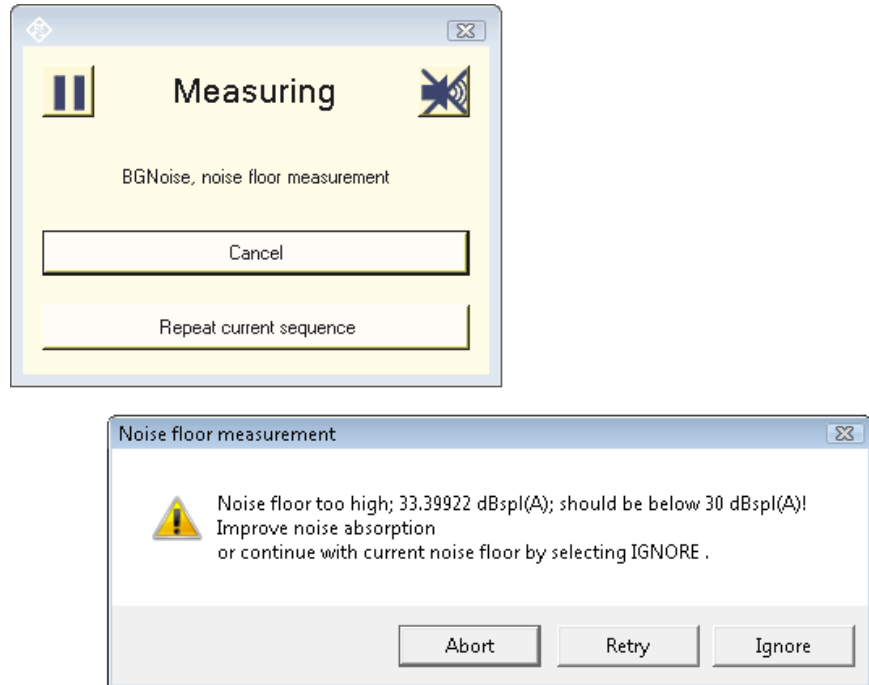

Fig. 78 Warning for exceeded noise floor limit.

This warning is suppressed if 'Ignore uncritical level warnings' is activated in configuration window. After the soundproofing has been improved, the measurement can be repeated. "Ignore" continues the calibration process although this limit has been exceeded.

Frequency Response of unequalized Speakers

The frequency response of each speaker before equalization is measured in the range of 40 Hz to 20 kHz (or the range selected as 'Bandwidth low/high' in configuration window, if modified).

The acceptable flatness deviation for fullrange speakers is max. ± 9 dB in the range 50 Hz to 10 kHz (or the range selected as 'Flatness start/end at' in configuration window, if modified).

The graph displays the frequency range that is to be equalized, the Y axis is scaled from -20 to +20 dB. The limit curve shows the range that is checked for flatness.

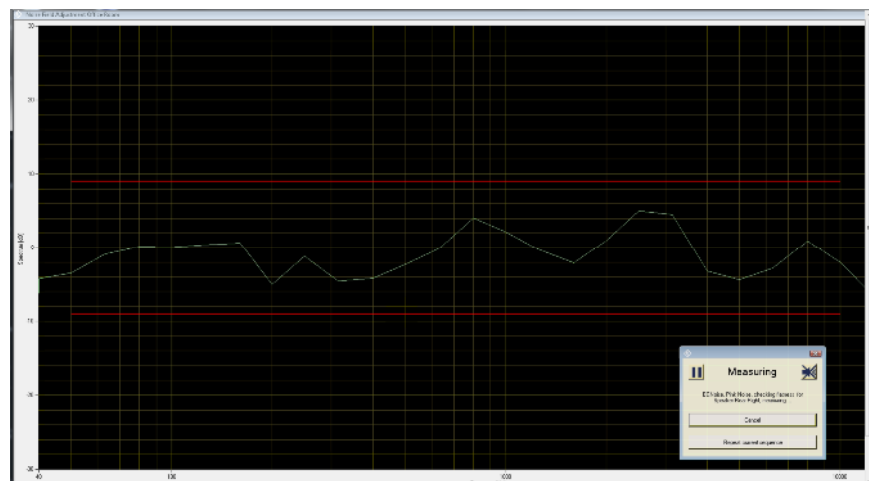

Fig. 79 Frequency response of unequalised fullrange speaker.

If the flatness deviation is above this value, equalization is hard to achieve for the room, and the room properties and the speaker layout should be improved before equalization is performed.

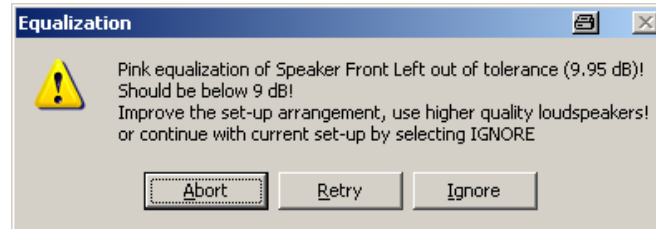

Fig. 80 Warning for excessive equalization needs.

'Ignore' continues the calibration process although this limit has been exceeded.

This warning is suppressed if 'Ignore uncritical level warnings' is activated in configuration window.

The final curve for *each* speaker and the flatness result for each *fullrange* speaker are added to the report.

The subwoofer frequency response can be used to determine the cutoff frequency, if unknown. If it is below the default value of 120 Hz, then the actual cutoff frequency must be modified in the configuration window. If the subwoofer does not pass frequencies down to 40 Hz, then the lowest third octave should not be equalized. In this case the user should set the Bandlimit Low in configuration window to 50 Hz. If it does not pass 50 Hz, then this subwoofer is not appropriate for this calibration.

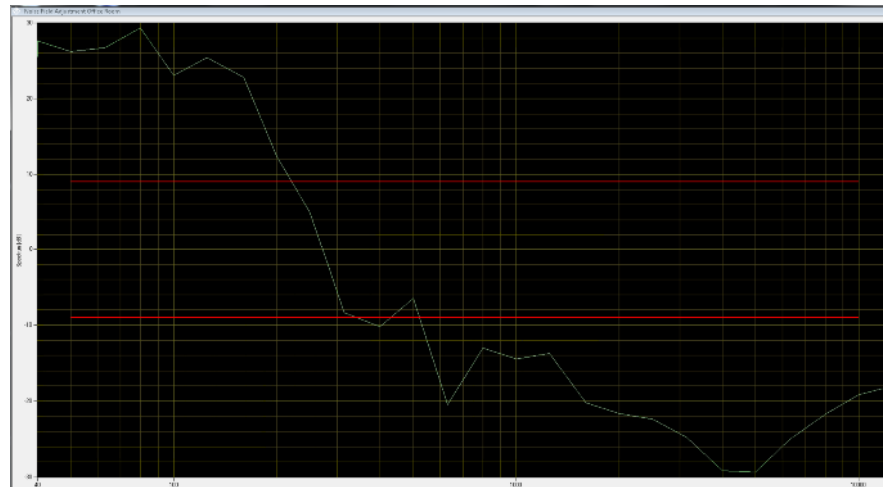

Fig. 81 Frequency response of unequalised subwoofer.

Total Harmonic Distortion

Measurement of the total harmonic distortion is performed for each speaker at nominal level in order to prevent speakers from being overdriven. Since destructive interference of the fundamental can occur at discrete frequencies which then results in a poorer total harmonic distortion being determined, the measurement is repeated at different frequencies in the case of an error.



Fig. 82 Warning for excessive total harmonic distortion of a speaker.

If speakers with a high total harmonic distortion are used, the tolerance limit 'Max THD' must be set higher (e.g. -10 dB) in the configuration window.

Cabling Check

This measurement which was already performed during the delay measurement is intended to ensure that the cabling is correct if the delay measurement is skipped and after the cabling has been changed. The results are the same as those under "Measurement of Level Change at Microphone Amplifier Output".

Shared Equalization Method

The fastest way to establish a valid calibration is to equalize room and speakers with only one signal – preferably Pink Noise – and use the equalization data for all ambiances. Afterwards the levels of all ambiances are individually adjusted. This is the default setting. Alternatively, the operator can select any of the ambiances as equalization signal in the noise calibration configuration window (see "Choice of calibration method").

At the beginning of the equalization a check is performed to determine whether a valid equalization data set is available. If this is the case, equalization can be skipped (by selecting "No") and the calibration process continues with individual level setting:

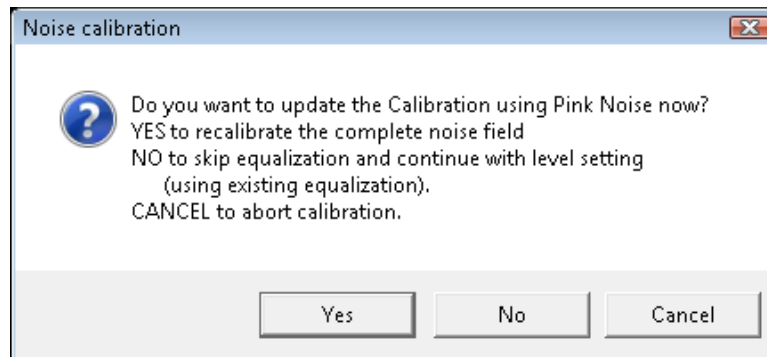

Fig. 83 Valid Shared Equalization, recalibration prompt.

Once started, the equalization as well as the subsequent level adjustment are largely performed without operator interaction. Input is only required if errors occur and the operator is prompted for a decision on the next action.

During calibration process, the equalization result graph – if equalization had been performed – and the values of the level adjustment are stored and can be reviewed in the report after termination or abort of calibration.

Individual Equalization Method

Alternatively the calibration process can generate individual equalization data for each ambiance. Depending on the room and speaker characteristic

this method could generate even better flatness, but it is very time consuming. Each ambiance will first be adjusted in level and then equalized. Before starting the calibration process the operator has to select this calibration method in the noise calibration configuration window (see “Choice of calibration method”).

For each ambiance the existence of valid calibration data is checked. If this is the case, equalization of this ambiance can be skipped by selecting “No”:

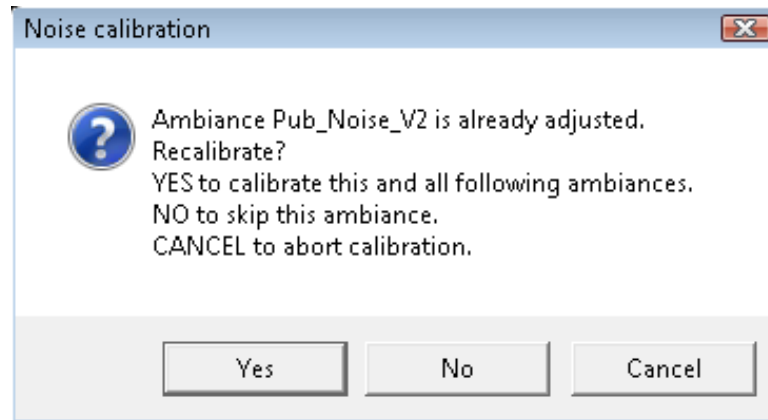

Fig. 84 Valid Individual Equalization, recalibration prompt.

Once started, the level adjustment and equalization are largely performed without operator interaction. Input is only required if errors occur and the operator is prompted for a decision on the next action.

During calibration process each measured equalization result graph and the values of the level adjustment are stored and can be reviewed in the report after termination or abort of calibration.

Level Adjustment

Level adjustment is performed with a maximum of five iteration steps. Normally two steps are sufficient to achieve the desired level tolerance (< 0.3 dB, can be modified as “Max level deviation” in the noise calibration configuration window). This number may not be sufficient for the subwoofer, especially for ambiances with low energy in the low-frequency range. A message is then displayed where the user can choose whether to accept the actual level deviation or to perform a further iteration. This dialog box by default is disabled in the noise calibration configuration window:



Fig. 85 Checkbox for suppressing the message caused by excessive single level deviation and other uncritical warnings.

Level adjustment is performed before (in case of individual equalization) or after (in other cases) the single speaker equalization.

Equalization

Equalization is performed in 4 steps:

- single speaker equalization
- pairwise equalization of the two left and the two right speakers
- flatness check of all speakers

- all speaker post equalization (optional)

Each of the two steps is performed with a maximum number of iteration steps which is selected in the configuration dialog box. 2 or 3 iterations are usually enough to achieve a flatness of 1 dB. If additional iterations are desired (up to 5), the operator can modify this setting in the configuration window

If the all speaker equalization check does not result in a PASS, the user can try to achieve a PASS by repeating this measurement. This may be successful if, for example, the tolerance violation is only slight or unwanted noise had impaired the measurement.

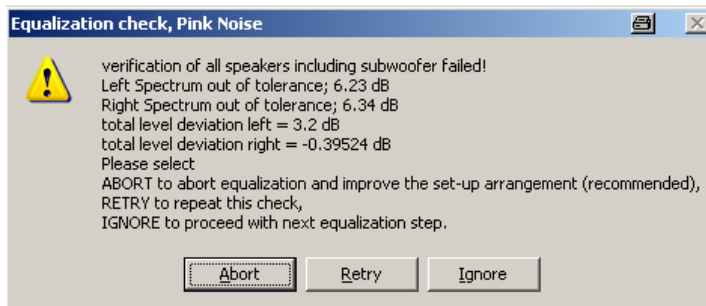

Fig. 86 Message for failed verification of all speaker equalizations.

This dialog can be suppressed by predefining the desired behavior in the configuration window:

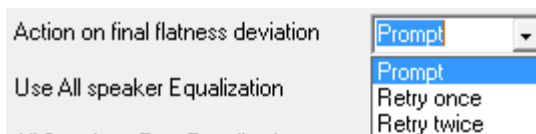

Fig. 87 Selection of action on failed verification of all speaker equalizations in the noise calibration configuration window.

Additionally optional post equalization can be performed if the all speaker equalization check fails. Activated by default, this part of the calibration slightly modifies the equalization of individual speakers to fulfil the flatness requirement. The result of each intermediate step is displayed as a trace during equalization. By selecting "Report intermediate steps" in configuration window all these traces are stored in the report.

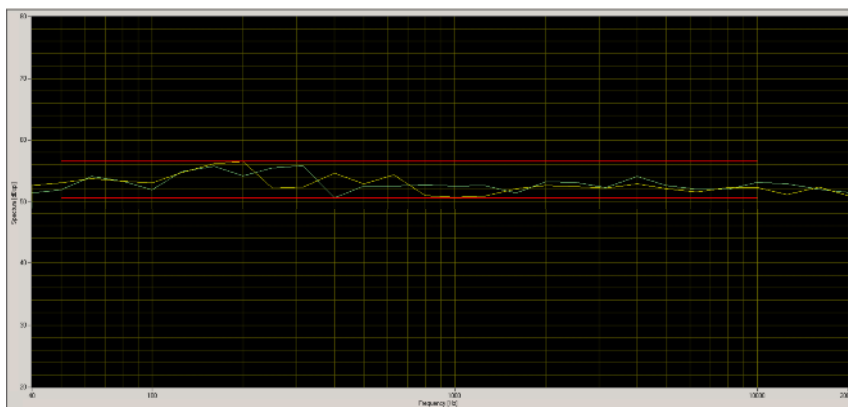

Fig. 88 Display of intermediate equalization results.

All Speaker Post Equalization

Following an unsuccessful all speaker equalization check, it is possible to adjust the all speaker equalization to within the ± 3 dB tolerance band by subsequent correction of individual speakers.

Since the algorithm recommended by ES 202 396-1 is extremely time-consuming and not always successful, a much faster post equalization is selected by default. Alternatively user can select the ETSI recommendation or deactivate the post equalization in the configuration window.

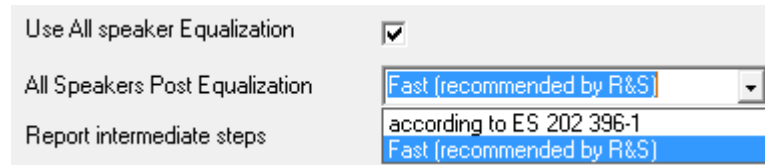

Fig. 89 Checkbox in the noise calibration configuration window for deactivating the additional all speaker equalization step.

Note: deactivating the “Use All speaker Equalization” is not recommended because it will cause a final FAIL of calibration if the first all speaker check fails.

If “All Speaker Post Equalization according to ES 202 396-1” is activated, these further equalization steps are performed:

- Measurement of the crosstalk flatness separately for left and right. If at least one of these is outside the tolerance, the crosstalk speaker which impairs the frequency response most is determined (by switching off the other crosstalk speaker). Starting with this speaker, the four crosstalk speakers are equalized again individually (next is the other speaker on the same side followed by the next worse speaker) until the interaction of all speakers is below the tolerance limit or repeated equalization of all four speakers was unsuccessful.
- If this equalization step was unsuccessful, adjustment with the direct speakers is attempted. Once again the direct speaker which impairs the frequency response most is determined. Starting with this speaker, the four direct speakers are equalized again individually until the interaction of all speakers is below the tolerance limit or repeated equalization of all four speakers was unsuccessful.

If “All Speaker Post Equalization Fast (recommended by R&S)” is activated, these further equalization steps are performed:

- Equalization of each pair (left and right) with the attenuated inverse frequency response of the *opposite* pair.
- If this equalization step was unsuccessful, then equalization of each pair (left and right) with the attenuated inverse frequency response of the *same* pair.

If this equalization step is also unsuccessful, equalization has definitively failed and must be repeated with improved room properties. After successful termination of the background noise field calibration the calibration data is valid and can be used for measurements in the presence of background noise.

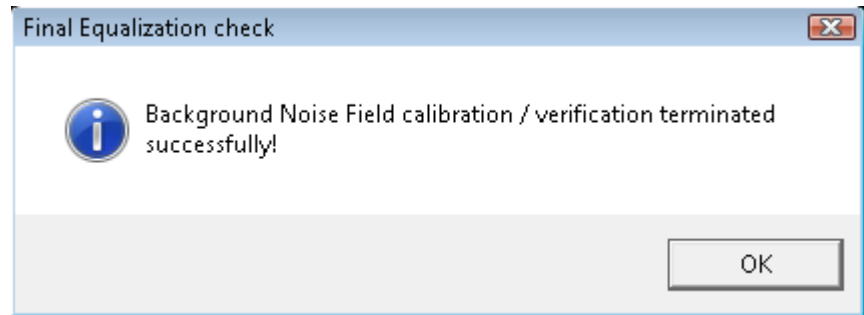

Fig. 90 Message of successful calibration or verification.

Final Test of All Ambiances

This test performs a flatness and level check of each ambiance, with the A-weighting filter activated. It can be performed during the calibration process or separately after a calibration had successfully been terminated. So it allows checking a valid calibration to see if any modification had been done that requires a recalibration.

For each checked ambiance a report entry is generated with the graph (documenting the flatness over frequency) and the numeric deviations of flatness and level for left and right channel. Note that the ± 3 dB tolerance limits in the graphs are displayed centered to the highest left and right deviation.

If performed during the calibration process the final test section additionally adjusts the total level to minimum level deviation of both channels. To have this final level optimization it is strongly recommended not to deactivate the final test!



Fig. 91 Checkbox for activation of the final test of all ambiances.

To perform the final test separately, the operator has to start the calibration and skip all calibration sections. Note that the preparatory measurements cannot be skipped but have to be done to ensure proper cabling. The final test cannot be skipped but of course aborted at any time.

Calibration Sections and Resuming Points

The calibration process consists of the following sections, depending on the calibration method used:

For Pink Noise Equalization or Equalization with shared ambiance:

- Delay Measurement
- Preparatory Measurements
- Pink Noise Frequency response before equalization
- Equalization with Pink noise or shared Ambiance
- Level adjustment of each ambiance
- Final test of all ambiances

For Individual Equalization of each ambiance:

- Delay Measurement

- Preparatory Measurements
- Pink Noise Frequency response before equalization
- Level adjustment *and Equalization* of each ambiance
- Final test of all ambiances

Resuming points are located after successful termination of

- Delay Measurement

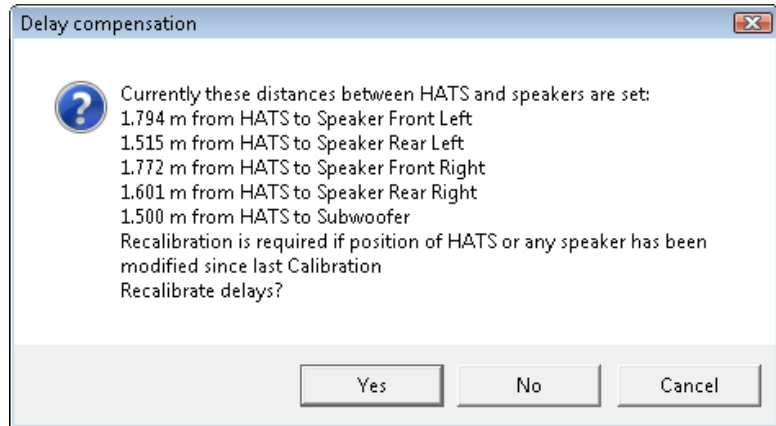

Fig. 92 Resuming Point after delay measurement

- Equalization with Pink noise or shared Ambiance

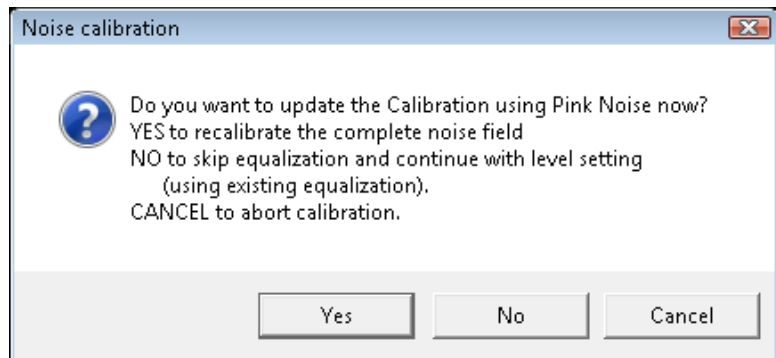

Fig. 93 Resuming Point after (shared) equalization

- Level adjustment (and Equalization) of each ambiance

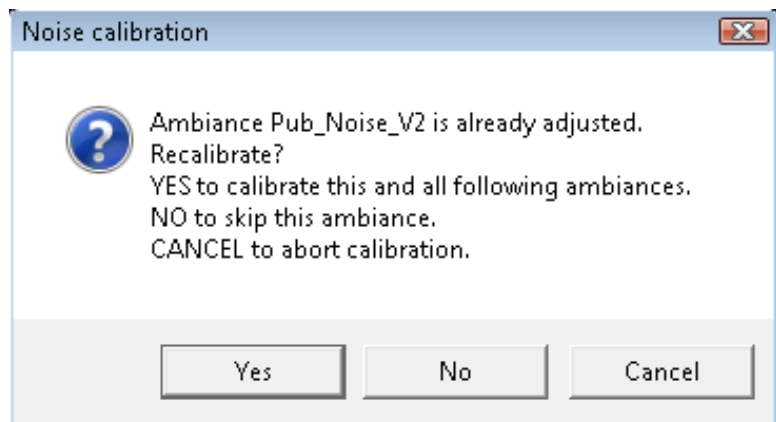

Fig. 94 Resuming Point after level adjustment or individual equalization of any ambiance, e.g. Pub_Noise_V2

Selecting 'Yes' always resumes the calibration at the current resuming point (with the current beginning calibration section), 'No' skips the current calibration section and goes to the next resuming point. If the calibration section following the current resuming point is not valid, then the calibration process will continue with this section.

Calibration Report

In the results overview of the main window an entry is available to open the report of the – failed, aborted or passed – calibration process. For each calibration that has been started a new entry is generated.

03/27/2015 12:18:03 Noise Field Adjustment Office Room PASS (null)

The complete report includes

- frequency response (unequalized) of all speakers
limit check is done for fullrange speakers only; no FAIL verdict

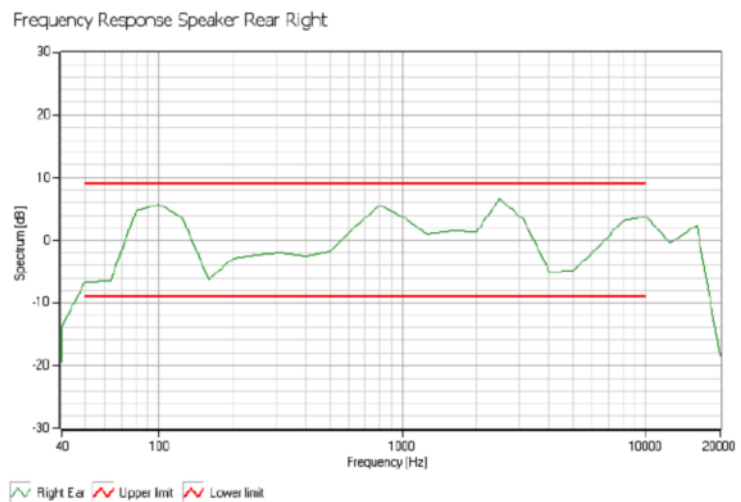

Fig. 95 Report Content: frequency response of unequalised (fullrange) speaker

- all speaker flatness of equalization method used (graph and values)
limit check for flatness and level deviation

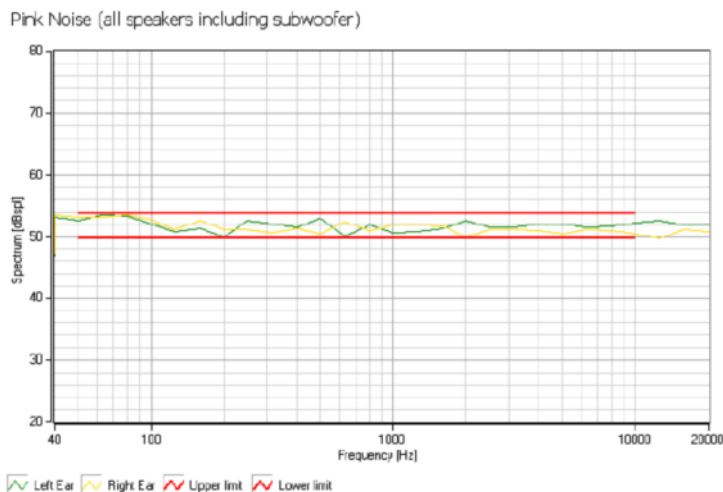

Fig. 96 Report Content: All speaker flatness after equalization

- final test results of all ambiances (graph, flatness and level deviation)
limit check for flatness (FAIL verdict for individual equalization method only) and level (including PASS/FAIL verdict)

Outside_Traffic_Crossroads (all speakers including subwoofer)

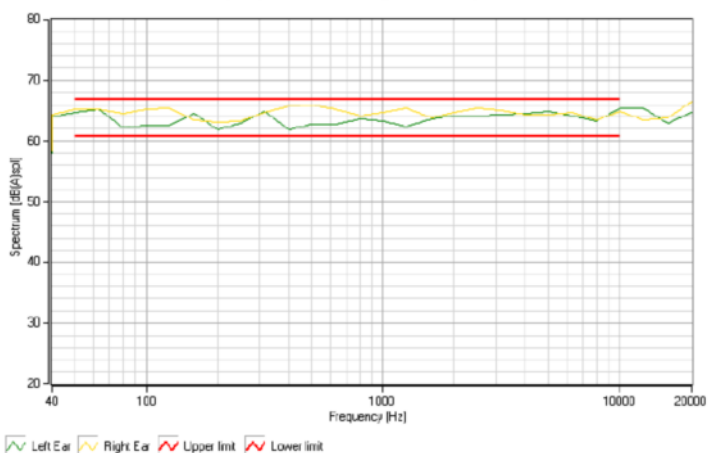

Fig. 97 Report Content: final test of each ambiance

- other numeric calibration results including Delays (verdict for fullrange speakers only), Noise Floor (no FAIL verdict)

Values:				
Value	Result	Lower Limit	Upper Limit	Verdict
Delay Speaker Front Left	5.23 ms	4.37 ms	7.29 ms	PASS
Delay Speaker Rear Left	4.42 ms	4.37 ms	7.29 ms	PASS
Delay Speaker Front Right	5.17 ms	4.37 ms	7.29 ms	PASS
Delay Speaker Rear Right	4.67 ms	4.37 ms	7.29 ms	PASS
Delay Subwoofer	4.37 ms			
Noise floor	33.78 dBsp(A)		30.00 dBsp(A)	
Flatness Speaker Front Left	11.63 dB		18.00 dB	PASS
Flatness Speaker Rear Left	15.46 dB		18.00 dB	PASS
Flatness Speaker Front Right	10.39 dB		18.00 dB	PASS
Flatness Speaker Rear Right	13.12 dB		18.00 dB	PASS
Pink Noise level dev left	-1.56 dB	-2.00 dB	2.00 dB	PASS
Pink Noise level dev right	-1.87 dB	-2.00 dB	2.00 dB	PASS
Pink Noise flatness left	3.49 dB		4.00 dB	PASS
Pink Noise flatness right	3.45 dB		4.00 dB	PASS

Fig. 98 Report Content: other numeric values

- Test Parameters (configuration window and internal settings) unused or irrelevant parameters are skipped

Test Parameters				
Description:		ETSI ES 202 396-1 V1.4.1 (2012-10) SW Version = Beta 2.3.4.64		
Name	Type	Value	Fix	
UPP setup folder	String	D:\UPV\	No	
Sonic speed [m/s]	Double	343.0	No	
retry if single flatness beyond [dB]	Double	1.0	No	
Max noise floor [dBsp(A)]	Double	30.0	No	
left microphone at UPV channel	Integer	2	No	
right microphone at UPV channel	Integer	1	No	
re-adjust level after equalization	Boolean	False	No	
Max equalization [+/- dB]	Double	9.0	No	
Number of fullrange speakers	Integer	4	No	
Number of subwoofers	Integer	1	No	
Subwoofer connected to UPP Channel	Boolean	7	No	
Maximum output level [dBV]	Double	13.78	No	
Ear equalization	String	ID	No	
Bandlimit low [Hz]	Double	40	No	
Bandlimit high [Hz]	Double	20000	No	
Flatness start at [Hz]	Double	50	No	
Flatness end at [Hz]	Double	10000	No	
Crossover Frequency [Hz]	Double	120	No	
Flatness Width [dB]	Double	4	No	
Min distance HATS to speaker [m]	Double	1.5	No	
Max distance HATS to speaker [m]	Double	2.5	No	
Max level deviation [dB]	Double	0.3	No	
Max THD [dB]	Double	-20	No	
Min Sound Pressure Level [dBsp]	Double	80	No	
Use Input Switcher UPZ	Boolean	True	No	
Modify speaker delay	Boolean	True	No	
Additional delay FL [ms]	Double	0	No	
Additional delay RL [ms]	Double	17	No	
Additional delay FR [ms]	Double	11	No	
Additional delay RR [ms]	Double	29	No	
Max iterations during equalization	Integer	3	No	
Use Pink Noise for all equalizations	Boolean	True	No	
Pink Noise level [dBsp(A)]	Double	65	No	
Pink Noise duration [s]	Double	30	No	
Pink Noise filename	String	PinkNoise16Bit120sFiltered.wav	No	
Final test of all ambiances	Boolean	True	No	
Ignore uncritical level warnings	Boolean	False	No	
Action on final flatness deviation	Integer	0	No	
Use All speaker Equalization	Boolean	True	No	
All speaker Post-Equalization policy	Integer	Fast (recommended by R&S)	No	
Report intermediate steps	Boolean	False	No	

Fig. 99 Report Content: Test parameters

- Calibration data (of HATS) used

Calibrations						
Date/Time	Usage	Manufacturer	Type	Serial	Operator	Value
12/03/2014 12:56:53	HATS Type 3.3 Art. Ear		Default		Meinof Glunz, CETECOM GmbH	-19.71 dB re 1 V / Pa
12/03/2014 12:57:43	Second Type 3.3 Art. Ear		Default		Meinof Glunz, CETECOM GmbH	-19.01 dB

Fig. 100 Report Content: HATS Calibration data

If the calibration process was aborted or partly skipped, only a subset of these data is stored

If “Report intermediate steps” is activated in configuration window, additional graphs and numeric values are stored which represent the iteration of single speaker equalization, pair of speaker equalization and all speaker equalization. To avoid this unnecessary information it is recommended to activate this option only for support purposes.

5 Data Entry for Reporting

Operator

Under “Data→Operator” an operator’s name can be entered which is stored in association with all calibration and measurement results. If “Operator” is activated in the report settings, the name will appear in all reports about these measurements.

Test object

Under “Data → Test object → New” a description of the device under test can be entered.

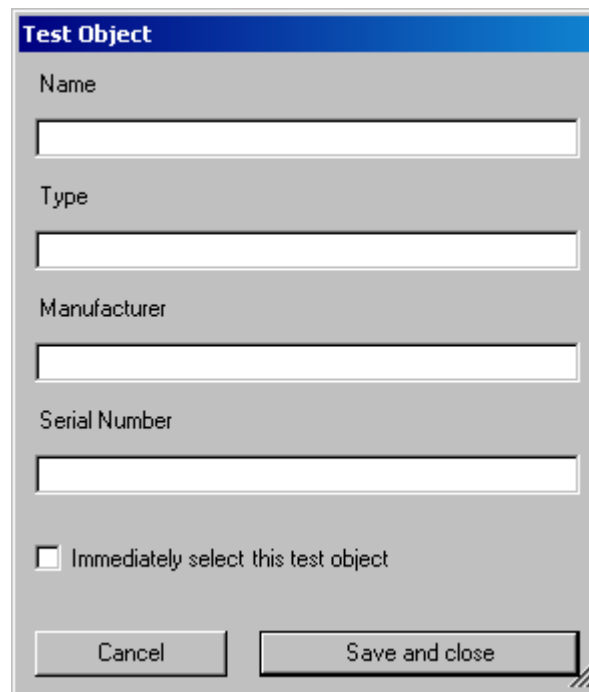

The image shows a software dialog box titled "Test Object". It contains four text input fields for "Name", "Type", "Manufacturer", and "Serial Number". Below these fields is a checkbox labeled "Immediately select this test object". At the bottom of the dialog are two buttons: "Cancel" and "Save and close".

Fig. 101 Window for input of information about a test object

If the checkbox “Immediately select this test object” is checked, the test object associated with the entered data is automatically selected upon closing the window. The data of this selected test object will be stored in association with all measurements and appear on the associated reports if “DUT information” is activated in the report settings.

A previously entered test object can be selected with “Data → Test object → Select”.

6 Measurements

General

Special problems caused by the coding and decoding algorithms of mobile phones are encountered when measuring acoustic characteristics. Vocoders are used to attain the lowest possible data rate. Mobile phone voice codecs are optimized for transmitting human speech with low data rate. Not the actual voice signals but only the filter and fundamental parameters required for signal reconstruction are transmitted.

Purely sinusoidal tones normally used for audio measurements cannot be transmitted with such a system. In commercially available mobile phones, no special test interface is accessible which would allow to measure the acoustic performance of the mobile without codec involved. Measurements during normal operation can therefore only be performed via the air interface with the speech coder and decoder included.

The codec types specified for the use in CDMA2000 phones even do not transmit complex artificial test signals like modulated multisine according to ITU-T P.501 or artificial speech according to ITU-T P.50 with sufficient fidelity. Therefore TIA-1042 and TIA-1042-A specify the use of natural speech.

Starting measurements

Measurements can be started from the “Measurement” menu. This menu contains either all available measurements, or the measurements belonging to the selected standard if the checkbox “Allow only selected measurements” in the “Options → Select standard” window is checked.

The menu “Standards” allows to start any measurement, whereby the measurements are structured into submenus according to the standards to which they belong. This allows a quick and easy access to all available measurements.

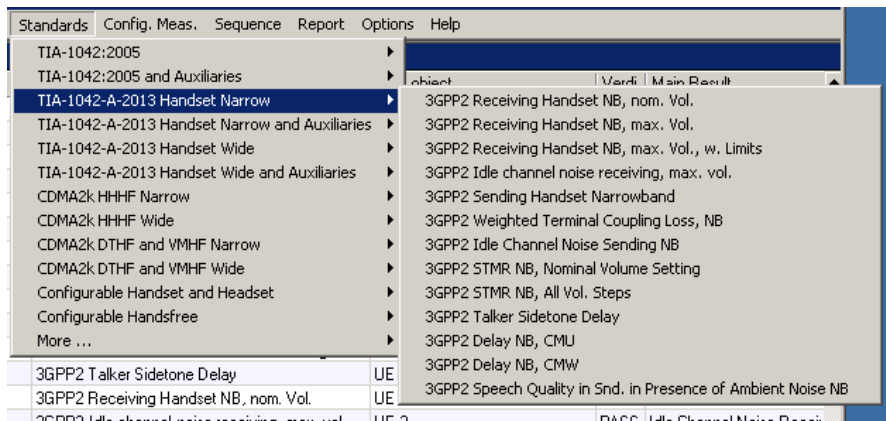

Fig. 102 “Standards” menu with submenu for narrow band handset tests according to TIA-1042-A-2013.

Functionality and control of the measurement macros

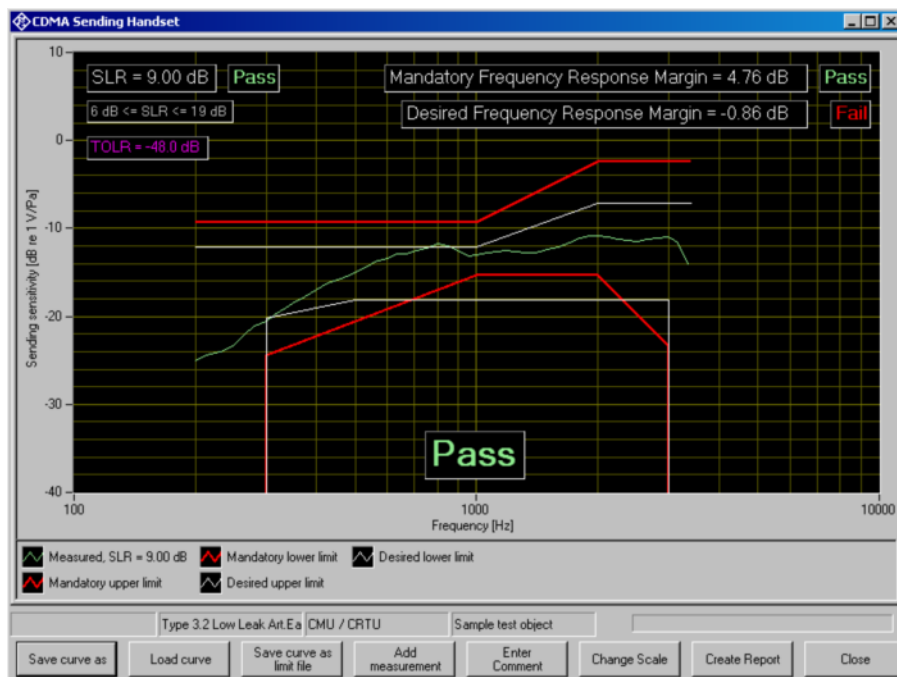

Fig. 103 Example of a measurement window

When a measurement macro is started, e.g. from the “Measurement” menu, the standardized measurement is immediately executed. With a single measurement, the window of the measurement macro stays open after the measurement is terminated. At that time, the following functionality is available:

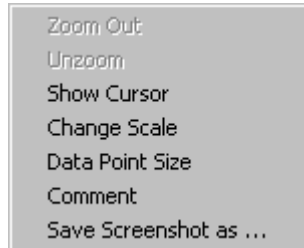

Fig. 104 Context menu of the graph window

Zooming

When the “Shift” key on the keyboard is pressed, the mouse cursor changes to the zoom cursor. When the left mouse button is pressed, a rectangle can be marked in the graph. As soon as the left mouse button is released, the graph is zoomed into the area of the marked rectangle

“Zoom Out” in the graph context menu reverses the last zooming step. “Unzoom” zooms completely out to the original scaling.

Changing the Scale of the Graph

“Change Scale” in the context menu opens a window in which the upper and lower bounds of both axes can be entered by numbers.

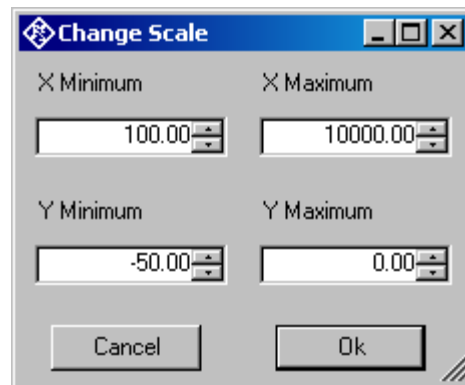

Fig. 105 Window for changing the scale of the graph

Cursor

When the item “Show Cursor” is marked in the graph context menu, a cursor is displayed which can be dragged along the graph with the mouse. X and Y values of the data points below the cursor are displayed.

Data Point Size

“Data Point Size” in the graph context menu opens a window in which the size of marks at the measured data points can be specified. Moving the mouse cursor over one of the marks causes the associated X and Y values to be displayed.

Making Additional Measurements

The softkey “Add Measurement” triggers another measurement according to the specification of the test. Loudness ratings and noise values are calculated and displayed in the legend. However, limits are not checked, and the report shows only the original results.

This function can e.g. be used to find the correct volume setting to pass nominal RLR. It can further be used for adjustments in the device under test.

Storing and Loading Curves

All curves in the graph can be stored to an ASCII file, and such curves can be loaded back into the graph. The softkey “Store Curve” opens a window in which a combo box offers choice between the legends of all curves in the graph. The curve associated in which the selected entry is stored to the file at the specified location.

Storing Curves as Limit Curves

With “Store As Limit Curve” a curve can be selected and stored into a R&S UPV format limit file with a specified shift in Y axis direction. This functionality can be used to generate limit curves from “golden” devices for evaluation purpose.

Entering a Comment

With the softkey “Enter Comment” or the item “Comment” in the graph context menu, a comment can be entered and edited which will appear in the report about the respective measurement.

Storing a Hardcopy of the Graph

With the menu item “Save Screenshot as ...” in the graph context menu, a hardcopy of the current graph window with all numeric displays, legend etc. can be stored as image. The current view of the graph including additional curves, current scaling and size is copied. However, colours are inverted to a printer-friendly colour set.

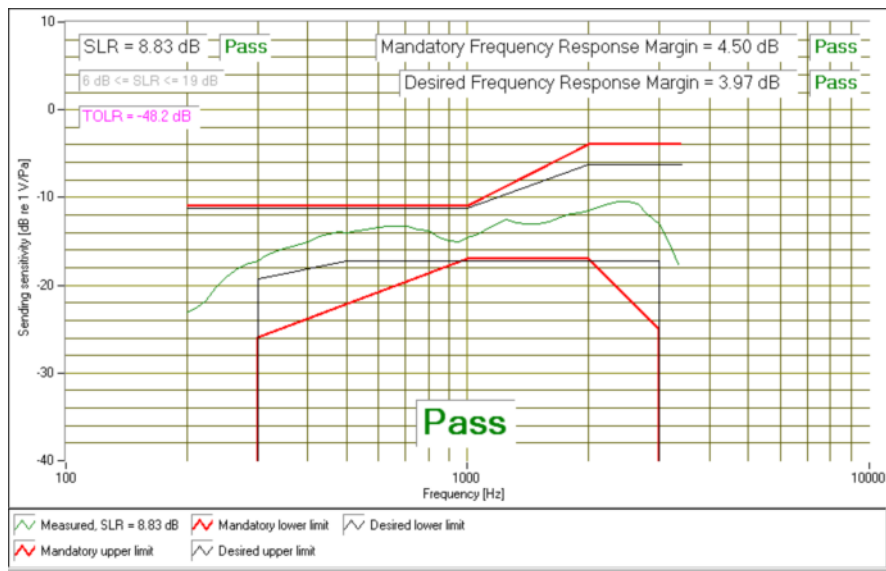

Fig. 106 Hardcopy of measurement graph

Creating a Report

The softkey “Create Report” causes a report to be prepared. The report preview window (see below) opens and shows the preview of the report. Buttons in the preview window allow to print the report or to export it to PDF, WORD, EXCEL or Rich Text format.

Closing the Measurement Window

The softkey “Close” closes the measurement window. The control is returned to the R&S UPV-K9 main window. All relevant data associated with the measurement is imported to the results data. A new entry appears for the measurement as new row on the bottom of the overview data grid in the main window.

Notes on Individual Measurements

Sending Frequency Response and Loudness Rating

Sending Frequency Response

The sending frequency response is specified as the transmission ratio in dB of the voltage at the decoder output to the input noise pressure at the artificial mouth.

The mobile phone under test is installed in the LRGP (loudness rating guard-ring position) according to ITU-T P.76, and the receiver is sealed to the artificial ear.

Natural speech with an active speech sound pressure level of -4.7 dBPa is created with the artificial mouth at the MRP (mouth reference point), and the corresponding output voltage spectrum is measured at the CMU speech

decoder output and compared to the reference spectrum obtained at the MRP.

The sending frequency response must be within the (floating) mandatory limit lines specified according to table 2.2-1 of TIA-1042. The absolute sensitivity is not taken into account.

Table 2.2-1 of TIA-1042 also specifies “desired” limit lines as a target for the acoustic design, which, however, are not mandatory to be passed. The sending tests of R&S UPV-K92 display also the desired limit template which is centred around the measured frequency response curve independently from the mandatory template. A verdict for the desired limit is also shown, which, however, does not influence the total verdict of the test case. TIA-1042-A does not specify desired limit lines.

For each of the two templates, the offset of the measured frequency response to the upper or lower limit line is calculated and then the whole limit template is shifted to be centred with respect to the measured curve. Then another limit check is performed. If the shifted curve is now within the limit lines, PASS is output, otherwise FAIL is displayed. The limit check is performed at each measured frequency. If the measured value and the end point of a limit line are not at the same frequency, it may happen that the trace slightly crosses a corner of the limit line although there are no limit violations. The remaining margin is displayed. A negative margin shows the amount of limit violation.

Sending Loudness Rating

The sending loudness rating (SLR) takes into account the absolute loudness in the transmit direction and weights the tones in compliance with the normal sensitivity of the average human ear.

To this end, for narrowband connections the frequencies (Hz) of bands 4 to 17 are evaluated according to table 1 of ITU-T P.79. For wideband connections bands 1 to 20 are evaluated.

Table 5 Band centre frequencies according to ITU-T P.79

Band	1	2	3	4	5	6	7	8	9	10
f_m /Hz	100	125	160	200	250	315	400	500	630	800

Band	11	12	13	14	15	16	17	18	19	20
f_m /Hz	1000	1250	1600	2000	2500	3150	4000	5000	6300	8000

The sensitivity at each frequency is defined as the ratio dBV/Pa referenced to the rated internal level in dBm0, and the sending loudness rating is calculated according to formula 5-1 of ITU-T P.79. Note that loudness rating values are loss values, i.e. a high loudness rating value indicates a low gain and a low loudness rating value indicates a high gain.

Due to the input sensitivity tolerance of the CMU speech coder, the individual sensitivity of the CMU used has to be taken into account in order to calculate the sending loudness rating (see calibration routines). According to TIA-1042, the sending loudness rating should be between 6 dB and 19 dB, with lower dB values corresponding to greater loudness (6 dB = maximum loudness, 19 dB = minimum loudness). Target SLR should be 11 dB. In TIA-1042-A the SLR shall fall within the range +11 dB to +5 dB. The measured SLR is indicated in a window in the frequency

response display and checked for compliance with these limits. In addition to the numeric value, either PASS or FAIL is displayed.

The general PASS or FAIL information is obtained from the limit check of the frequency response curve and the loudness rating. PASS is output only if both the curve and the loudness value are within tolerances.

The AMPS version of this test (“AMPS Sending Handset”) automatically looks for existing CDMA2000 results with the same mobile. If a result is found, the loudness contrast is displayed and checked against the limit of ± 3 dB.

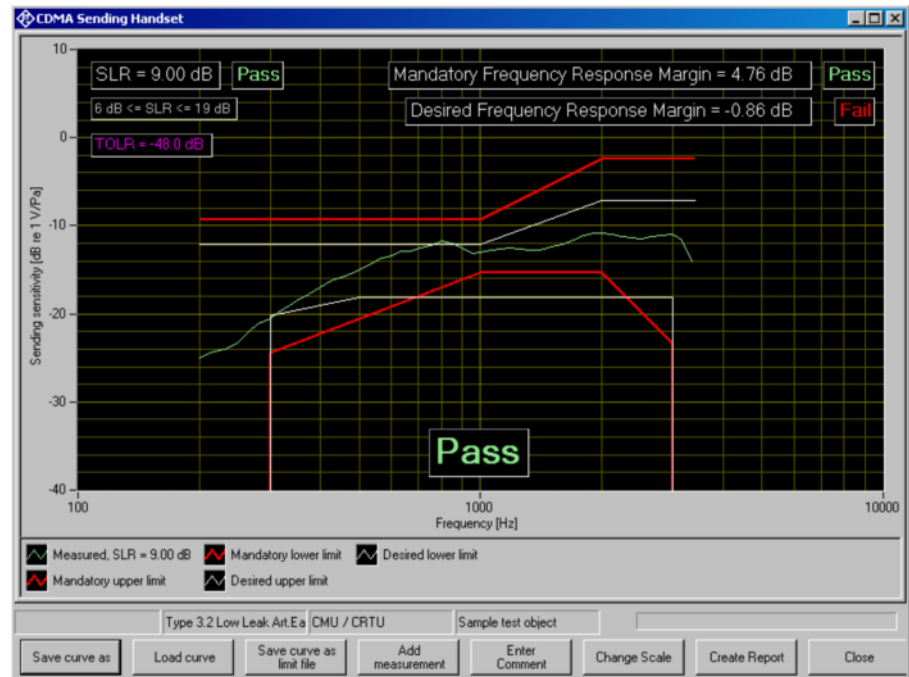

Fig. 107 Sending frequency response with SLR value displayed

Receiving Frequency Response and Loudness Rating

The following two measurement definitions are available, as the permissible limit values of the loudness rating depend on the volume set in the mobile phone under test: “CDMA Receiving Handset, nom. Vol.” checks loudness rating limits for nominal loudness setting and at the same time compliance with the frequency response limit template. “CDMA Receiving Handset, max. Vol.” checks the receiving loudness rating at the highest volume setting against a minimum. (Note: As the loudness rating is a loss value, a high RLR is associated with a soft speech signal and a low RLR is associated with a loud speech signal).

Receiving Frequency Response

The receiving frequency response is specified as the transmission ratio in dB of the sound pressure in the artificial ear to the input voltage at the speech coder input of the CMU. The measured sound pressure is referenced to the ear reference point (ERP). For ear types 3.x, the measuring microphone is applied to the drum reference point (DRP), which is the reason why any measured value has to be converted to the ERP by means of calibration factors. According to TIA-1042, the measurement must be referenced to the ear reference point (ERP). For information only there are separate measurements supplied with R&S UPV-K92 which

measure referenced to the DRP.

The mobile phone under test is installed in the LRGP (ITU-T P.76) or on the HATS. In case of ear type 3.2, the receiver is sealed to the rubber gasket of the artificial ear. If the low leak version of this ear type is used, care must be taken that the defined leak opening at the circumference of the artificial ear is not accidentally covered.

The speech coder is driven such that the received speech has an active level of -19 dBm₀ (TIA-1042) or -16 dBm₀ (TIA-1042-A) on the digital side. The sound pressure in the artificial ear is measured and evaluated.

Ear type 1 is not specified in TIA-1042 for measurements on CDMA2000 mobile phones. TIA-1042-A mandates the use of ear type 3.3 for receiving tests.

The receiving frequency response must be within the (floating) mandatory limit lines specified according to table 2.1-1 of TIA-1042 or TIA-1042-A, respectively. The absolute sensitivity is not taken into account.

Table 2.1-1 of TIA-1042 also specifies “desired” limit lines as a target for the acoustic design, which, however, are not mandatory to be passed. The receiving tests of R&S UPV-K92 display also the desired limit template which is centred around the measured frequency response curve independently from the mandatory template. A verdict for the desired limit is also shown, which, however, does not influence the total verdict of the test case. TIA-1042-A does not specify desired limit lines.

For each template, The margins of the measured frequency response to the upper and lower limit lines are calculated separately, and then the whole template is shifted such that the resulting margins to upper and lower limit are equal. Then another limit check is performed. If the shifted curve is now within the limit lines, PASS is output, otherwise FAIL is displayed. The limit check is performed at each measured frequency. If the measured value and the end point of a limit line are not at the same frequency, it may happen that the trace slightly crosses a corner of the limit line although there are no limit violations. The remaining margin is displayed. A negative margin shows the amount of limit violation.

Receiving Loudness Rating

The receiving loudness rating (RLR) takes into account the absolute loudness in the receive direction and weights the tones in compliance with the difference between an average speech spectrum and the normal threshold of hearing in quiet of the average human ear.

To this end, for narrowband connections bands 4 to 17 are evaluated according to table 1 of ITU-T P.79. For wideband connections bands 1 to 20 are evaluated.

The sensitivity at each frequency is specified as the ratio dBPa/V referenced to the rated internal level, and the receiving loudness rating is calculated according to formula 5-1 of ITU-T P.79.

Due to the input sensitivity tolerance of the speech encoder, the individual sensitivity of the encoder input used has to be taken into account in order to calculate the receiving loudness rating (see section “Calibration” above).

The receiving loudness rating depends on the receiving loudness set on the mobile phone under test and, according to TIA-1042, should be between -5 dB and +5 dB at a rated nominal loudness setting, with lower dB values corresponding to a higher loudness. According to TIA-1042-A, the RLR shall be between -1 dB and +5 dB, and the nominal target value should be 2 dB.

To prevent damage to the human ear, the maximum receiving loudness must not exceed a certain value. With the user volume setting of the mobile under test set to maximum, the RLR must not fall below -18 dB according to TIA-1042 and it shall not be less (louder) than -13 dB according to TIA-1042-A.

The measured RLR is indicated in a window in the frequency response display and checked for compliance with these limits. In addition to the numeric value, either PASS or FAIL is displayed.

According to TIA-1042-A, the RLR with the receive volume control set to minimum shall not be higher (quieter) than 18 dB.

The AMPS version of this test (“AMPS Receiving Handset”) automatically looks for existing CDMA2000 results with the same mobile and same volume control setting. If a result is found, the loudness contrast is displayed and checked against the limit of ± 3 dB.

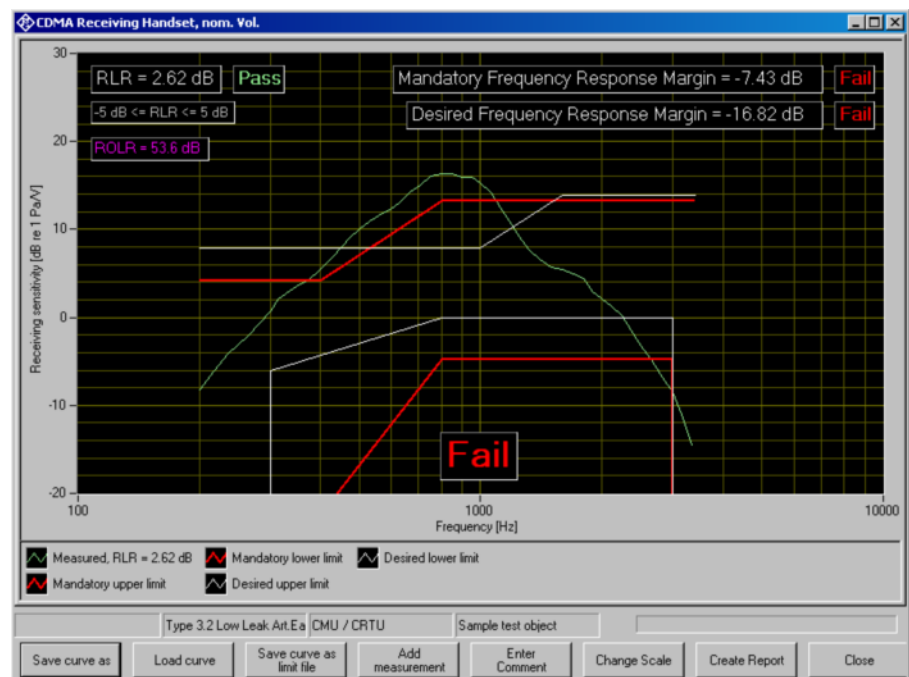

Fig. 108 Receiving frequency response with RLR value displayed

Wideband to Narrowband Loudness Contrast

For a mobile phone supporting both narrowband and wideband speech and tested according to TIA-1042-A, the differences between the sending loudness ratings in wideband mode and narrowband mode and the differences between the receiving loudness ratings in wideband and narrowband mode have to be reported as wideband to narrowband loudness contrast.

For this purpose the UPV-K9y program provides a pseudo measurement which does not really perform a measurement on the mobile phone under test, but collects the loudness ratings from the result database and calculates the difference. The evaluated loudness ratings must be measured with the currently selected device under test. If more than one result exists for a specific loudness rating of this device under test, the latest result is used.

Weighted Terminal Coupling Loss (TCLw)

The echo loss is the attenuation between the speech coder input and the speech decoder output (gain of speech coder + decoder = 1). Normally the echo loss is caused by internal acoustic coupling between the telephone receiver and the microphone. Since the echo considerably reduces the sound transmission quality, it must not exceed a certain value.

The mobile phone under test is positioned according to one of the options listed in IEEE Std 269-2002. These options comprise the handset to be mounted on the ear simulator used for the receiving measurements, suspended in free air under anechoic conditions or facing a hard, smooth surface free of any obstacles for at least 500 mm. The positioning of the mobile for this test will greatly influence the result. Hence it should be noted, e.g. as comment in the measurement result.

Artificial speech “Echoloss” is used as test signal and applied to the speech coder. The spectral energy distribution of the generated signal is measured in the third-octave bands from 200 Hz to 4 kHz. At the same time, the spectral distribution in the output signal of the speech decoder is measured. The echo loss is calculated from the differences of the bands according to ITU-T G.122.

The actual gain of the speech coder and decoder must also be considered in the result. This value is available in the CMU after calibration of the coder. In addition, the attenuation of the echo path is displayed as a curve.

TIA-1042 specifies a TCLw of at least 45 dB; mobile phones with good echo cancellers can meet this requirement. Since the microphone of the mobile phone under test also picks up any side noise and treats it like an echo, it is essential that the test chamber is well shielded against external noise.

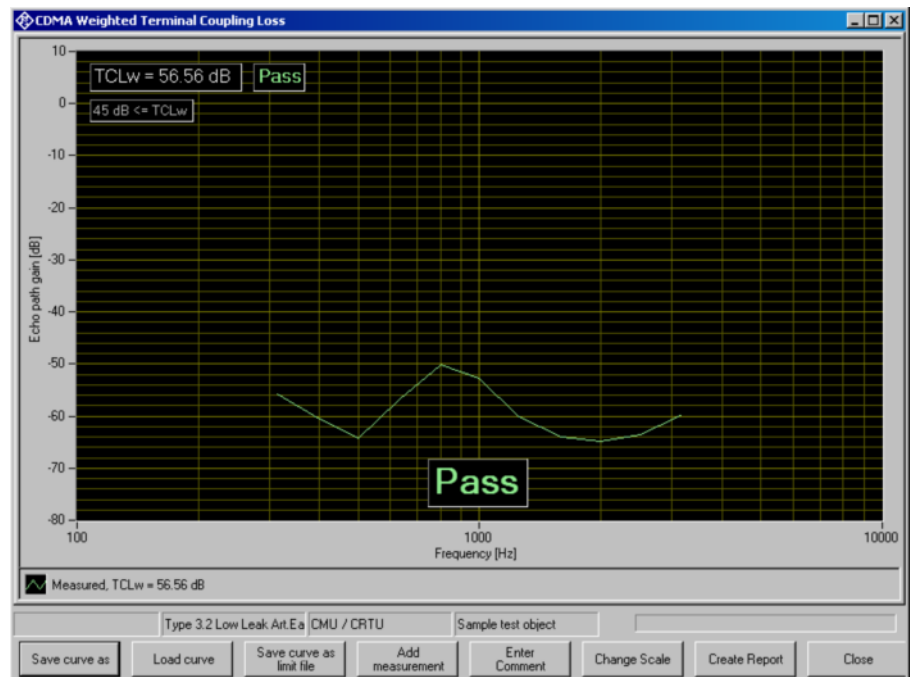

Fig. 109 Typical result of echo loss measurement

Peak Acoustic Pressure Level

To avoid damage to the ear in use of the mobile phone, the maximum

sound pressure level generated by the earpiece in the ear of the user should be limited. IEC 60950-1 specifies a respective test using the test signal "PeakLevel", a heavily clipped artificial signal which is designed to produce a high output level at the speech decoder. The maximum sound pressure level obtained in the measurement is checked against a maximum of 42 dBPa (136 dB relative to 20 μ Pa) as specified in IEC 60950-1.

If a receive volume control is provided at the mobile, this test should be performed with maximum volume setting.

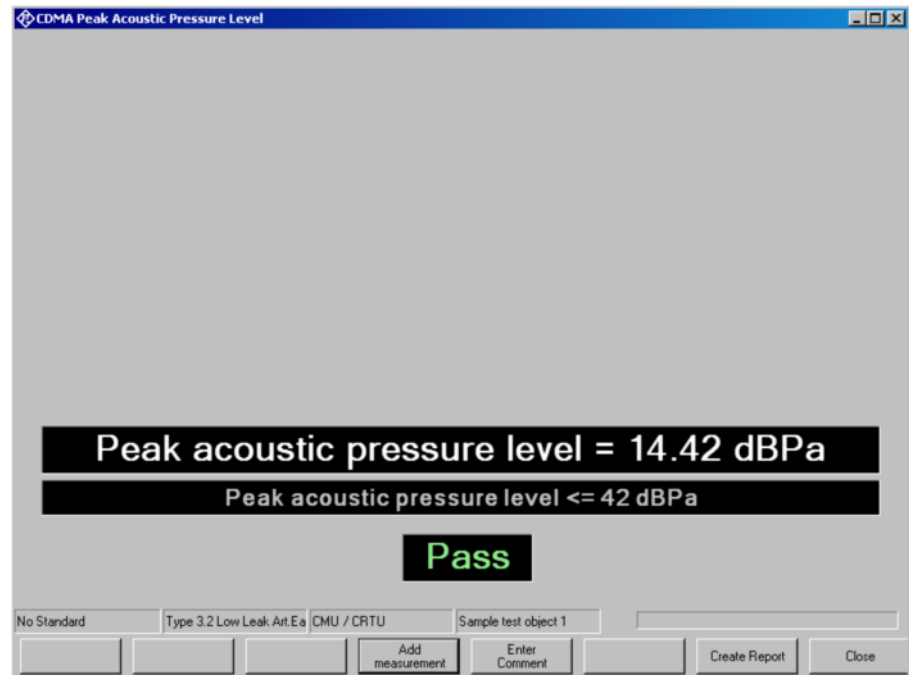

Fig. 110 Typical result of peak acoustic measurement

Sidetone Masking Rating (STMR)

This test is not specified in TIA-1042. In this standard it is provided for reference only.

The sidetone path is the deliberate output of a part of the signal picked up by the microphone to the phone's receiver. This is to create a natural hearing impression for the person speaking on the phone as is encountered under normal conditions involving an acoustic path between mouth and ear.

If an artificial ear type 3.2 is used (TIA-1042), the mobile phone under test is installed in the LRGP (ITU-T P.76), and the receiver is sealed to the artificial ear. According to TIA-1042-A the mobile phone is mounted on the HATS

The artificial mouth generates a test signal with a sound pressure of -4.7 dBPa at the MRP (mouth reference point), and the sound pressure is measured in the artificial ear. In the test according to TIA-1042-A, real speech is used as test signal. In the measurement provided for reference for use with TIA-1042, the test signal is a modulated multisine.

The attenuation of the sidetone path is determined at each frequency according to table 1 of ITU-T P.79, and the sidetone masking rating (STMR) is calculated according to formula 5-1 of ITU-T P.79 with the weighting factors of table 3 of ITU-T P.79 taken into account. In addition, the gain of the sidetone path is displayed as a curve.

According to TIA-1042-A the STMR shall be between 15 dB and 23 dB for the nominal setting of the volume control. For all other positions of the volume control, the STMR shall be ≥ 10 dB.



Fig. 111 Typical measurement of sidetone masking rating

Stability Margin

This test is provided for reference only. It is not specified in TIA-1042 nor in TIA-1042-A.

The stability margin is measured to test the susceptibility of the phone to acoustic feedback and instability.

For the test, the telephone is placed on an even, hard board with the receiver and microphone pointing downwards.

A loop is closed in the R&S UPV between the receiving and the voice channel, and an overall gain of 6 dB is set. The gain of the coder is automatically taken into account (see also Echo Loss).

To activate the loop, a noise signal of -10 dBm0 in line with ITU-T O.131 is applied for 1 s and then switched off, with the loop remaining closed.

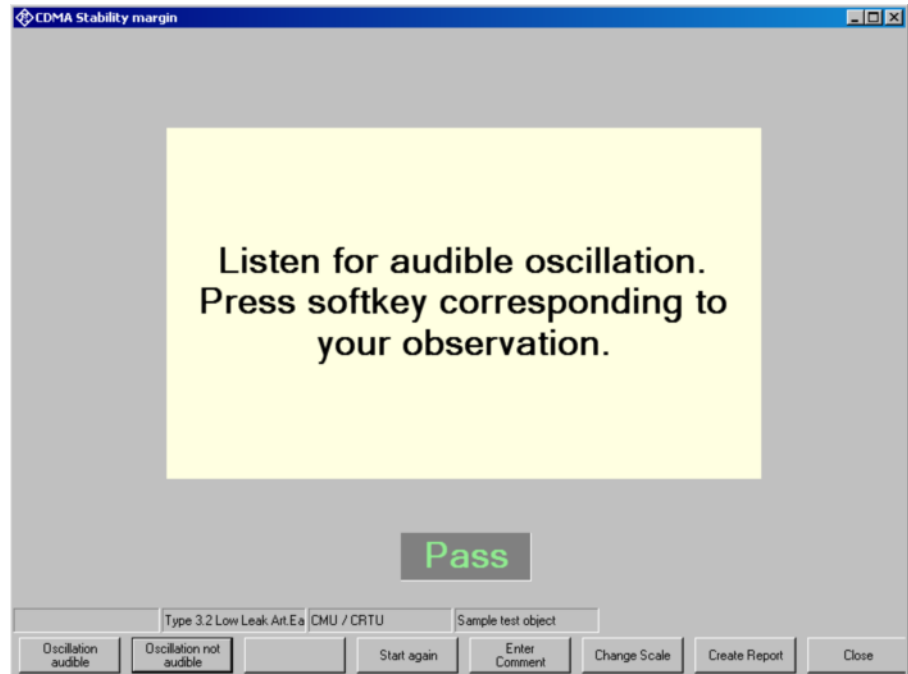

Fig. 112 Window during stability margin test

The test person has to listen to determine whether any resonances or oscillations are produced. If there are no oscillations, the minimum requirements according to 3GPP TS 26.131 for a stability margin of 6 dB are met.

Stability Loss

This test is not specified in TIA-1042 or TIA-1042-A. It is provided as an auxiliary measurement for reference.

From release 10 of 3GPP TS 26.132, the stability margin test case is replaced by a stability loss test case. The test measured the attenuation between input and output of the system simulator, similar to the echo loss measurement. Other than with the echo loss measurement, the result is not integrated over frequency, but the spectral minimum is searched.

The test routine first looks for valid delay results of the selected device under test in sending and receiving direction. If no results are found, or if the delay results are older than specified in the parameters of this measurement, the UE has to be first mounted on the HATS for the delay measurements.

When valid delay values are available, the mobile has to be set up according to the following illustration:

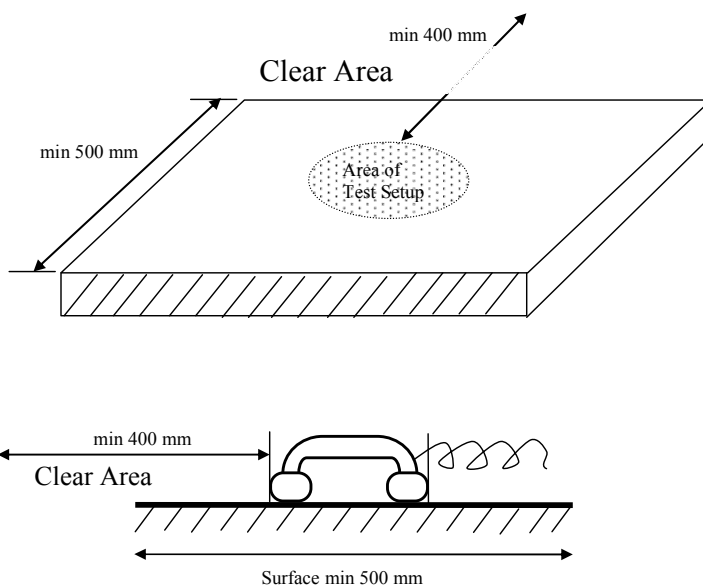

Fig. 113 Test setup for stability loss test

As soon as the operator has acknowledged the UE to be correctly placed, a PN signal with high rms level is send to the network interface, and the returned signal at the output of the system simulator after the roundtrip delay is measured. The spectral attenuation is calculated from the difference of the level spectra.

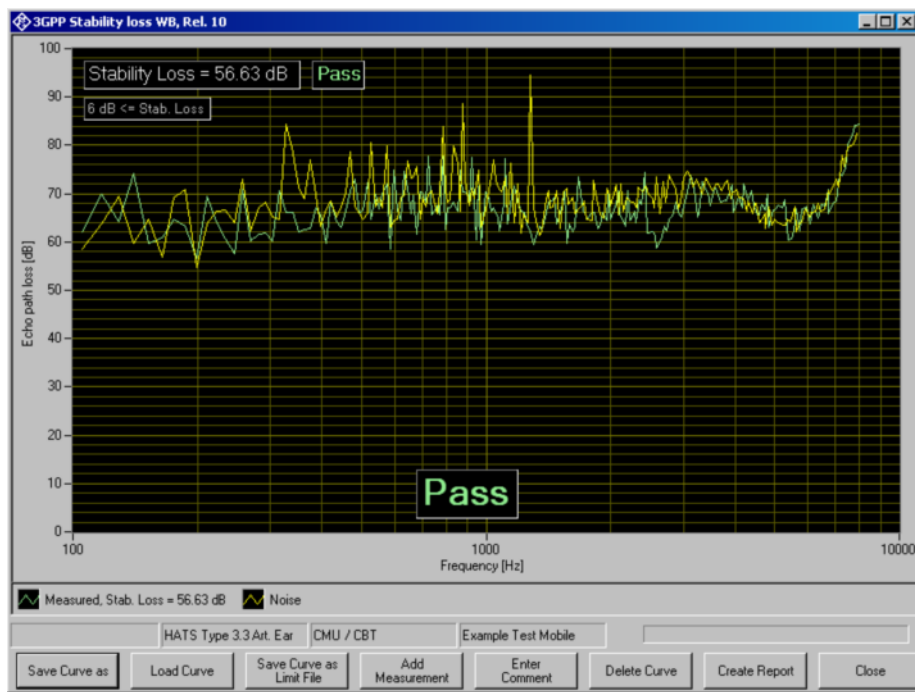

Fig. 114 Window of stability loss test

A second measurement is performed without test signal to show the noise “floor” of the measurement. As the graph plots the path loss, the noise-induced result will usually be above the stability loss result.

Echo Control Characteristics

This test is not specified in TIA-1042 or TIA-1042-A. It is provided as an auxiliary measurement for reference.

The “Echo Control Characteristics” test has been added to 3GPP TS 26.132 in Release 11. It requires update key UPV-K9201 and option second analog generator (UPV-B3). It is a so-called “double-talk” test in which test signals are sent in both uplink and downlink direction simultaneously. The signal sent by the mobile to the network simulator is analyzed.

The uplink signal contains a section with single words separated by pauses (“single near-end words”) and a section with continuous talk (“continuous double-talk”). These sections are analysed separately.

In a first run, both uplink and downlink signals are played simultaneously. In a second run only the uplink signal is played while the downlink path is silent. The level difference between both situations is analyzed in frames of 5 ms. The results are summarized separately for the following two categories:

“Double-talk” frames are defined as the frames where both the far-end (receiving direction) signal includes active speech (extended with a hang-over period of 200 ms) and the near-end signal is composed of active speech.

“Far-end single-talk adjacent to double-talk” frames are similarly defined as the frames with active far-end speech and no active near-end speech.

The test method measures the duration of any level difference between the sending signal of a double-talk sequence (where the echo canceller has been exposed to simultaneous echo and near-end speech) and the sending signal of the same near-end speech only. The level difference is classified for each of the two situations (with and without simultaneous downlink signal) and for each of the two classified frame categories separately into eight categories according to the following figure and table:

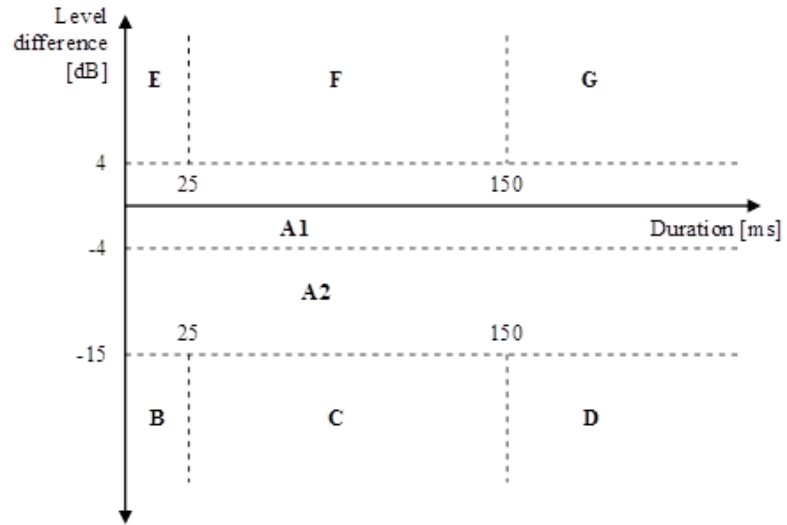

Fig. 115 Classification of level differences and their duration into categories

Cat	Level difference (ΔL)	Duration (D)	Description
A1	$-4 \text{ dB} \leq \Delta L < 4 \text{ dB}$		Full-duplex and full transparency
A2	$-15 \text{ dB} \leq \Delta L < -4 \text{ dB}$		Full-duplex with level loss in Tx
B	$\Delta L < -15 \text{ dB}$	$D < 25 \text{ ms}$	Very short clipping
C	$\Delta L < -15 \text{ dB}$	$25 \text{ ms} \leq D < 150 \text{ ms}$	Short clipping resulting in loss of syllables
D	$\Delta L < -15 \text{ dB}$	$D \geq 150 \text{ ms}$	Clipping resulting in loss of words
E	$\Delta L \geq 4 \text{ dB}$	$D < 25 \text{ ms}$	Very short residual echo
F	$\Delta L \geq 4 \text{ dB}$	$25 \text{ ms} \leq D < 150 \text{ ms}$	Echo bursts
G	$\Delta L \geq 4 \text{ dB}$	$D \geq 150 \text{ ms}$	Continuous echo

Table 6 Description of categories

For each category, the ratio of frames in this category to the total number of frames is given, as well as the average level difference.

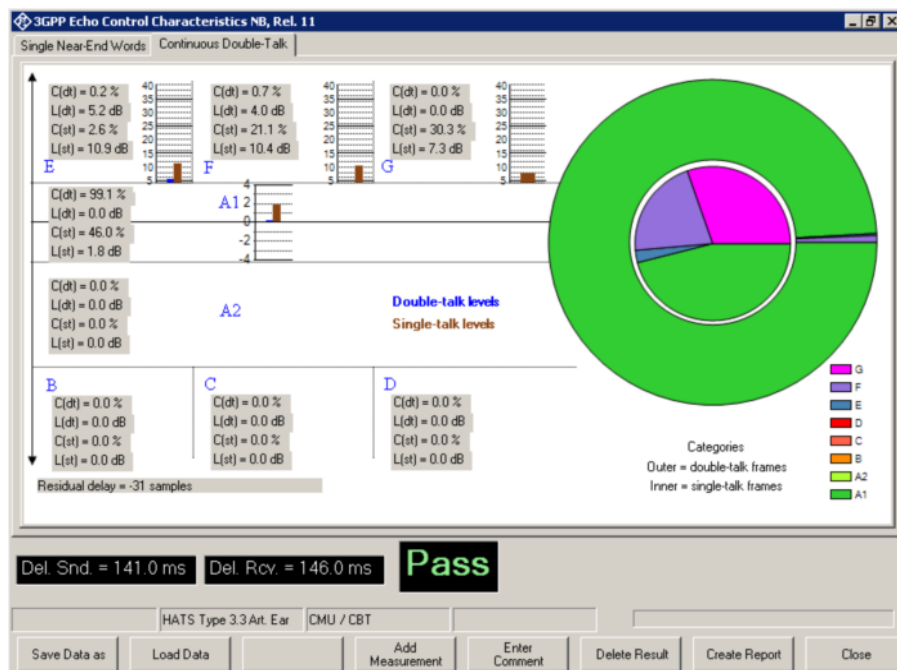

Fig. 116 Result screen of the “Echo Control Characteristics” test.

Interpretation of the results:

A positive level difference means that the level of the signal sent by the mobile is higher with simultaneous downlink speech than without. This is an indication of echo.

Short duration (category E) indicated short echo bursts.

Long duration (category G) indicates continuous echo.

A negative level difference is an indication of clipped uplink speech.

Short duration (category B) indicates short clipping, e.g. at the start of sentences or words.

Medium duration (category C) indicates loss of syllables.

Long duration (category D) indicates continuous high attenuation.

Sending Distortion

This test is provided for reference only. It is not specified in TIA-1042 nor in TIA-1042-A.

The mobile phone under test is installed in the LRGP or on the HATS.

There are two versions of this test according to 3GPP TS 26.132. The earlier version is valid up to release 8 and provided as auxiliary measurement to TIA-1042. The latest version is valid from release 9 and provided as auxiliary measurement to TIA-1042-A.

A pulsed sinusoidal tone with a pulse length of approx. 360 ms is used for the measurement.

For tests according to the earlier version, the frequency of the tone is 1015 Hz. At this frequency, coding yields a sufficiently stable output signal. Voice activity detection continues to be active in the mobile phone under test due to this pulsating signal.

The test signal is generated with the artificial mouth at the MRP (mouth reference point) and the SINAD value of the received signal is measured at the R&S CMU200 decoder output.

The acoustic reference level (ARL) is defined as the sound pressure which creates a signal level of -10 dBm0 in the transmit channel. In the earlier version, an automatic routine varies the sound pressure at the artificial mouth until the desired level is attained. This value is then used as a reference for determining the SINAD value versus level. The SINAD value is measured at sound pressures between -35 dB and +10 dB relative to the acoustic reference level (ARL) and compared with the limits specified in table 7 of 26.131 of 3GPP.

Signal processing of a modern mobile phone comprises a voice activity detector which determines whether a voice signal is present or whether the sending signal just comprises background noise. For this reason the sending distortion measurement omits levels below -25 dB and starts at high test tone levels gradually reducing the level.

The measurement is performed up to a maximum sound pressure of 10 dBPa at the artificial mouth if the value 10 dB relative to ARL with 10 dBPa cannot be attained. The actual trace may therefore end at a lower pressure. This occurs for mobile phones under test which have a low sensitivity in the transmit direction.

If the measured trace is above the limit line, PASS is output, otherwise FAIL is displayed.



Fig. 117 Sending distortion measurement

In the latest version of this test, additional measurements are performed at the frequencies of 315 Hz, 408 Hz, 510 Hz and 816 Hz with a SPL of -4.7 dBPa at the MRP. Other than in the previous version of the test, the levels are not defined relative to ARL, but as absolute SPL at the MRP. A CSS activation signal is issued before each measurement to activate the VAD (voice activity detector) of the mobile under test. Alternatively an activation signal specified by the terminal manufacturer may be used. To avoid an impact of the activation signal on the result due to the processing delay in

the transmission chain, the test routine comprises a delay measurement. The start of the analysis is delayed against the start of the test signal by the measured delay time.

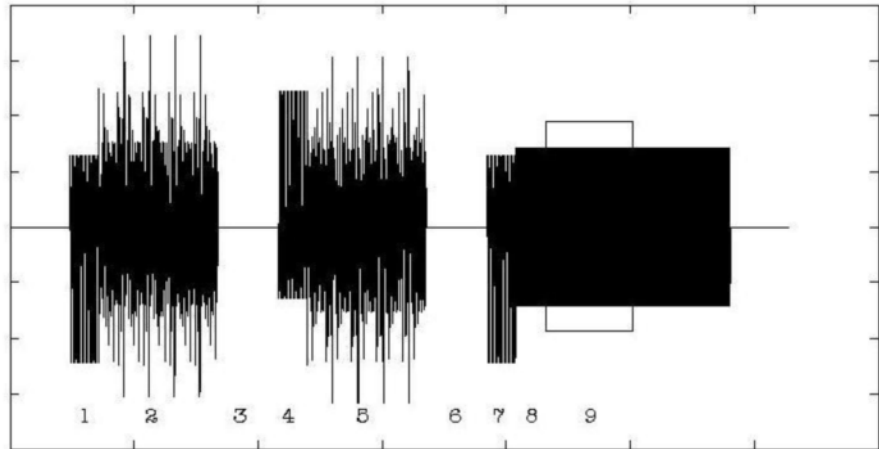

Fig. 118 Recommended activation signal according to the latest version of the sending distortion test

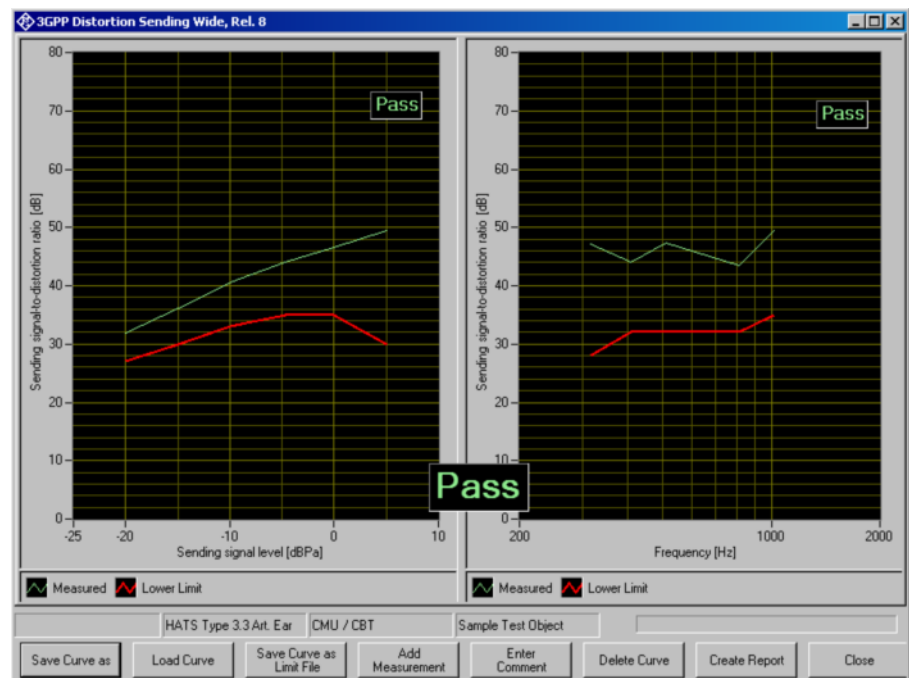

Fig. 119 Sending distortion measurement for wideband according to the latest version of the test

The UPV-K9y software provides the CSS activation signal as a default. However, before first use the signal has to be imported using “Options → Activation Signal → Import” (see Chapter 2). This step checks the conditions on the wav file and calculates the active level of the signal. With the same menu item also other wave files can be imported for use as activation signal. The wav files must be mono with 48 kHz sampling frequency and have a duration of 10 seconds or less.

For the sending direction the activation signal must be pre-equalized according to the inverse frequency response of the artificial mouth. This can be done during import of the wav file. After a re-calibration of the artificial mouth, the equalization has become obsolete and has to be re-done. The macro for the test case automatically detects an obsolete equalization of the activation signal and does a new equalization before the test is started.

If more than one activation signal is imported at the same time, the signal to be used can be globally chosen with menu item "Options → Activation Signal → Select". In addition, the measurement definition for this test case has a parameter to specify the file name without extension of the activation signal to be used. If this parameter is provided, it overrides the global choice of the activation signal. Thus the test can be repeated several times within a sequence, using different activation signals.

The test macro for distortion tests with activation signals from wav files also provides a spectrum display of the signal sent by the mobile. This is provided for information e.g. for troubleshooting purpose.

Receiving Distortion

This test is provided for reference only. It is not specified in TIA-1042 nor in TIA-1042-A.

The mobile phone under test is installed in the LRGP (ITU-T P.76) with the receiver sealed to the artificial ear, or on the HATS.

The SINAD ratio in the receiving path is measured as a function of the acoustic signal level.

There are two versions of this test according to 3GPP TS 26.132. The earlier version is valid up to release 8 of 3GPP TS 26.132 and provided as auxiliary measurement to TIA-1042. The latest version is valid from release 9 of TS 26.132 and provided as auxiliary measurement to TIA-1042-A.

A pulsed sinusoidal tone is used for the measurement.

For tests according to up to release 8 (narrowband) and up to release 7 (wideband), the frequency of the tone is 1015 Hz. For measurements according to later releases the frequency is 1020 Hz (see also table 12 below). At these frequencies, coding yields a sufficiently stable output signal.

Voice activity detection continues to be active due to this pulsating signal.

The test signal is applied to the input of the speech coder, and the SINAD value of the sound pressure in the artificial ear is measured with psophometric weighting according to ITU-T G.714.

The SINAD value of the sound pressure is measured at levels between -45 dBm0 and 0.

The measurement is performed up to a maximum sound pressure of 10 dBPa in the artificial ear; the actual trace may end at an earlier point if this maximum sound pressure is reached.

If the operator desires to see the receiving distortion value at the point exceeding 10 dBPa, this can be achieved by pressing the "add measurement" button. This causes the measurement to be repeated at all specified levels. The second measurement is not taken into account for reporting and Pass/Fail decision.

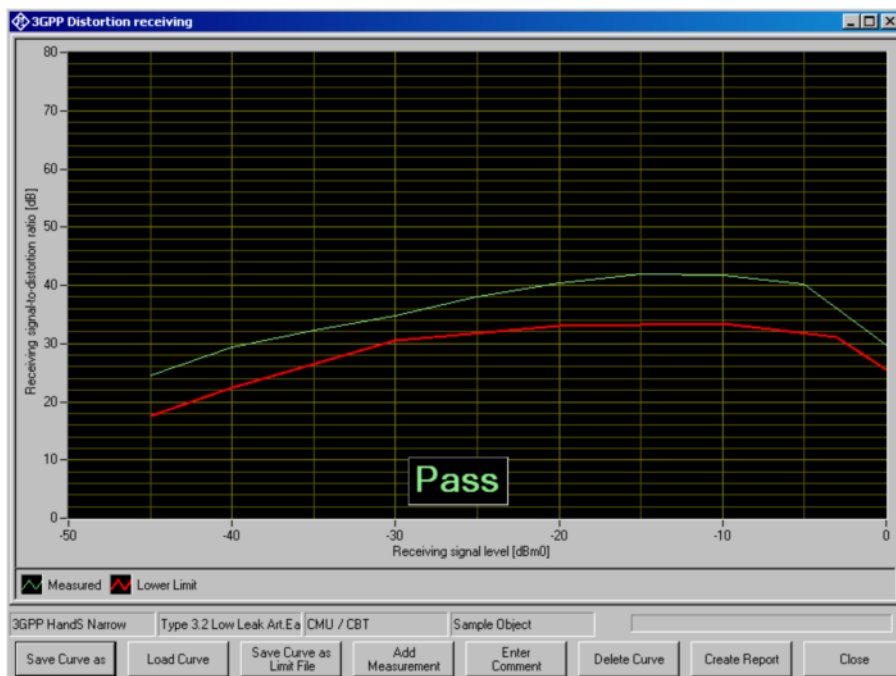

Fig. 120 Typical result of receiving distortion measurement

For tests according to the latest version, additional measurements are performed at the frequencies of 315 Hz, 408 Hz, 510 Hz and 816 Hz with a digital level of -16 dBm0 at the network interface (encoder input). An activation signal precedes the test signal. To avoid an impact of the activation signal on the result due to the processing delay in the transmission chain, the test routine comprises a delay measurement. The start of the analysis is delayed against the start of the test signal by the measured delay time.

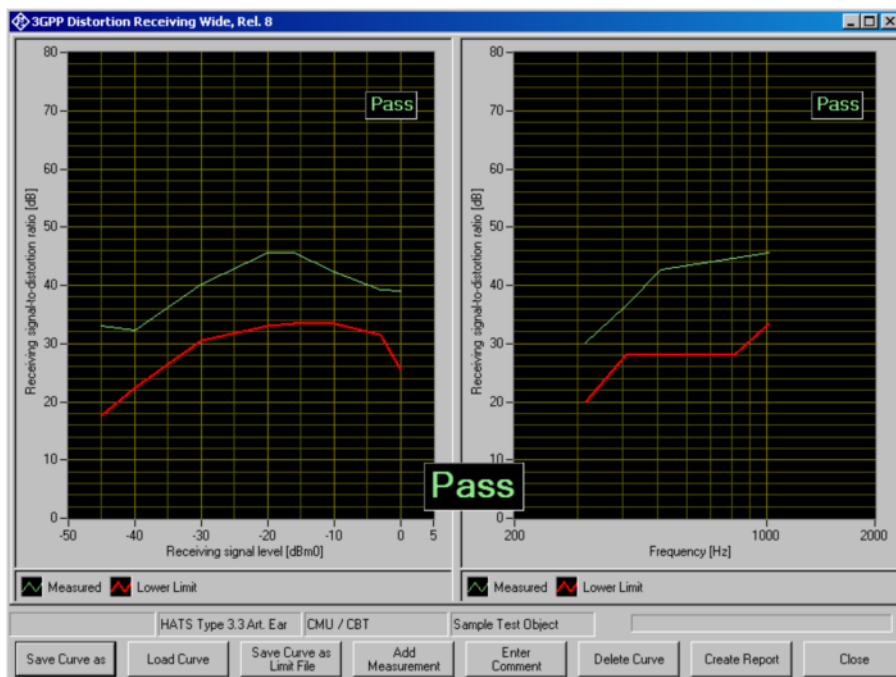

Fig. 121 Typical result of receiving distortion measurement in wideband according to release 8.

A CSS activation signal is recommended. Alternatively an activation signal specified by the terminal manufacturer may be used.

The UPV-K9y software provides the CSS activation signal as a default. However, before first use the signal has to be imported using “Options → Activation Signal → Import” (see Chapter 2). This step checks the conditions on the wav file and calculates the active level of the signal. With the same menu item also other wave files can be imported for use as activation signal. The wav files must be mono with 48 kHz sampling frequency and have a duration of 10 seconds or less.

If more than one activation signal is imported at the same time, the signal to be used can be globally chosen with menu item “Options → Activation Signal → Select”. In addition, the measurement definition for this test case has a parameter to specify the file name of the activation signal to be used (without extension). If this parameter is provided, it overrides the global choice of the activation signal. Thus the test can be repeated several times within a sequence, using different activation signals.

The test macro for distortion tests with activation signals from wav files also provides a spectrum display of the signal output at the earpiece of the mobile. This is provided for information e.g. for troubleshooting purpose.

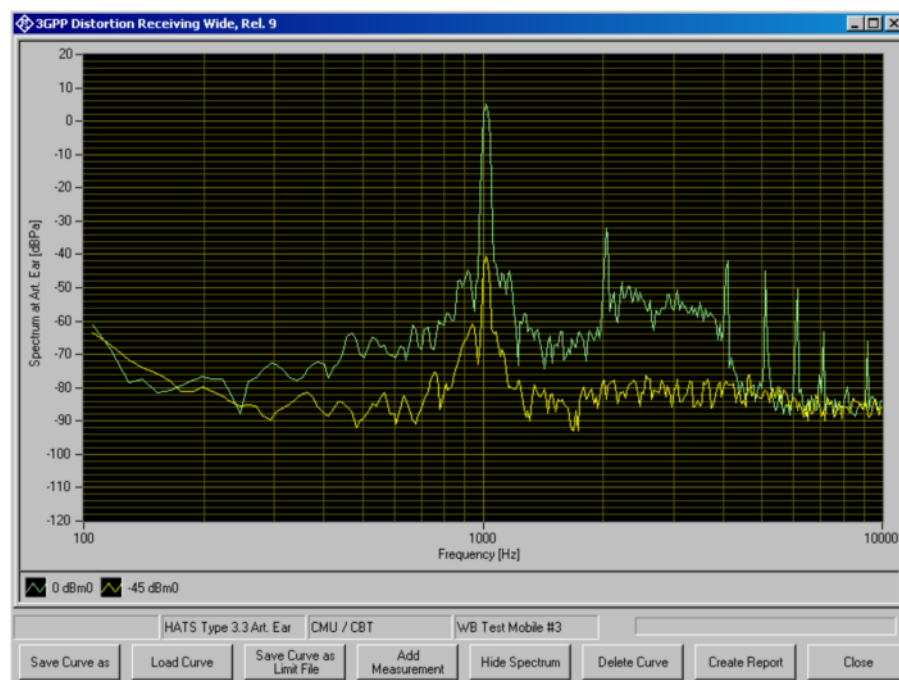

Fig. 122 Spectrum display of the receiving distortion test

During the test, the latest spectrum is displayed. After the test has finished, button “Show Spectrum” or “Hide Spectrum”, respectively, toggles between spectrum display and result display. In this state the spectra to be displayed can be configured in the context menu of the graph, and the spectra can be exported to ASCII files.

Idle Channel Noise Sending

In TIA-1042 this test is provided for reference only.

The noise voltage at the speech decoder output is measured with the phone set up in a quiet environment (<30 dB(A)).

When using a type 3.2 ear, the mobile phone under test is installed in the LRGP (ITU-T P.76). When using a type 3.3 ear, the mobile phone under test is mounted on the HATS.

The decoder output voltage is measured, weighted psophometrically according to ITU-T G.223 and recalculated for the internal level in dBm0p.

To keep the mobile phone under test in the normal operating mode, a pulsed signal is applied. The noise level is measured during the signal pauses. The voice activity decoder (VAD) is activated and the mobile phone remains in the active normal sending mode.

The idle noise level should not exceed -64 dBm0p. The measured noise voltage is also displayed as a spectrum, making it easier to find causes if the limit value is exceeded.

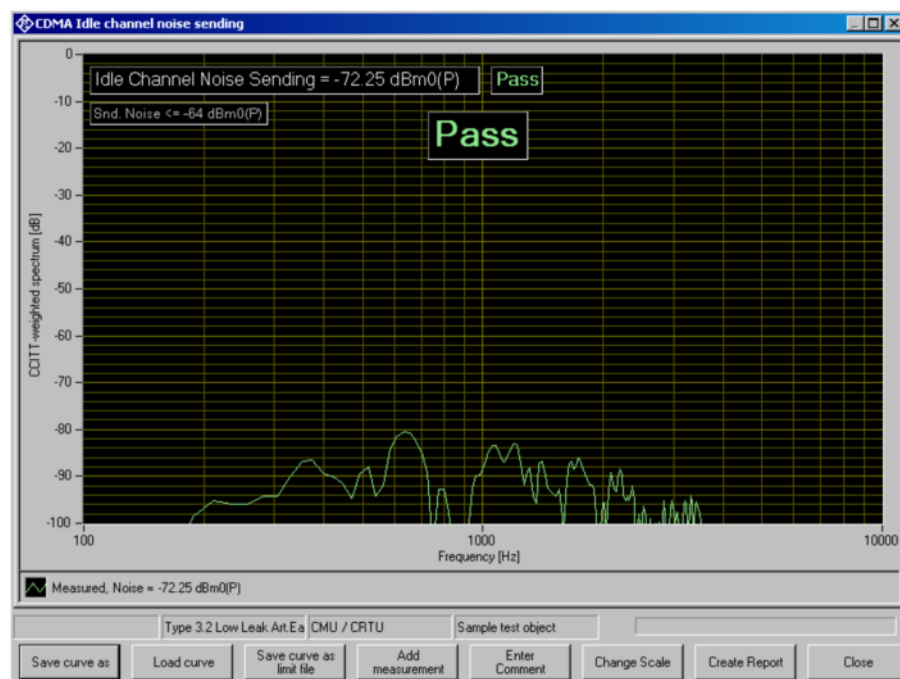

Fig. 123 Typical result of sending noise measurement

In TIA-1042-A a newer version of this test is provided, using a CSS activation signal. When measuring a narrowband correction, the noise is psophometrically weighted. In a wideband measurement, the noise is A-weighted.

Idle Channel Noise Receiving

In TIA-1042 this test is provided for reference only.

The sound pressure in the artificial ear is measured with the phone set up in a quiet environment.

When using a type 3.2 ear, the mobile phone under test is installed in the LRGP (ITU-T P.76), and the receiver is sealed to the artificial ear. When using a type 3.3 ear, the mobile phone under test is mounted on the HATS.

The sound pressure in the artificial ear is measured with A-weighting on.

To keep the mobile phone under test in the normal operating mode, a

pulsed signal is applied to the speech coder input. The noise level is measured during the signal pauses. The voice activity decoder is activated and the mobile phone remains in the active normal receiving mode.

With rated loudness set on the mobile phone, the sound pressure should not exceed -57 dBPa(A). In this case use test “3GPP Idle channel noise receiving, nom. Vol”.

At maximum receiving loudness, the sound pressure should not exceed -54 dBPa(A). In this case use test “3GPP Idle channel noise receiving, max. Vol.”.

The measured noise voltage is also displayed as a spectrum, making it easier to find causes if the limit value is exceeded.

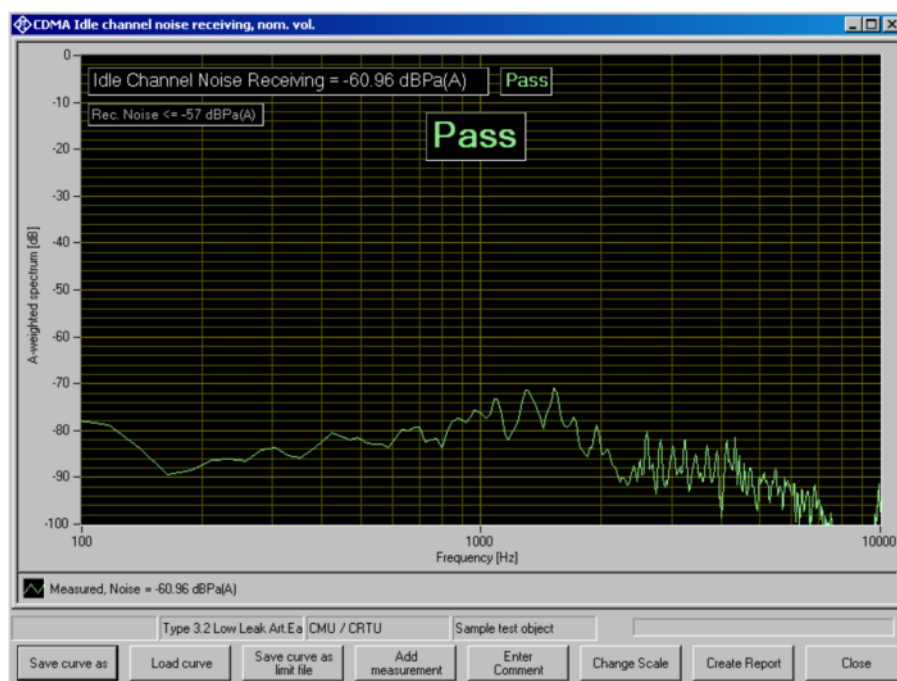

Fig. 124 Typical result of receiving noise measurement

This measurement makes high demands on the sound insulation of the test chamber and the S/N ratio of the measuring microphone including preamplifier in the artificial ear. A comparison measurement with the test mobile phone switched off or without a DUT shows the measurement reserves of the test equipment. Due to the low inherent noise of the Audio Analyzer R&S UPV, measurements can be made to about -80 dBPa(A) at 0 dB microphone gain, and even to lower values when a higher microphone gain is set.

In TIA-1042-A a newer version of this test is provided, using a CSS activation signal.

Talker Sidetone Delay

The sidetone delay measurement is specified in TIA-1042-A only.

The sidetone delay is measured by cross-correlation between the electric input signal to the artificial mouth and the electric signal from the artificial

ear. The sidetone delay is defined as difference between first and second maximum of the cross-correlation envelope.

Test signal is a short word “five” of real speech according to ITU-T P.501. Before the test, the test signal is offline-filtered according to the mouth speaker equalization curve obtained during mouth calibration. This offline filtering is only performed when the valid speaker equalization curve is newer than the file with the filtered test signal.

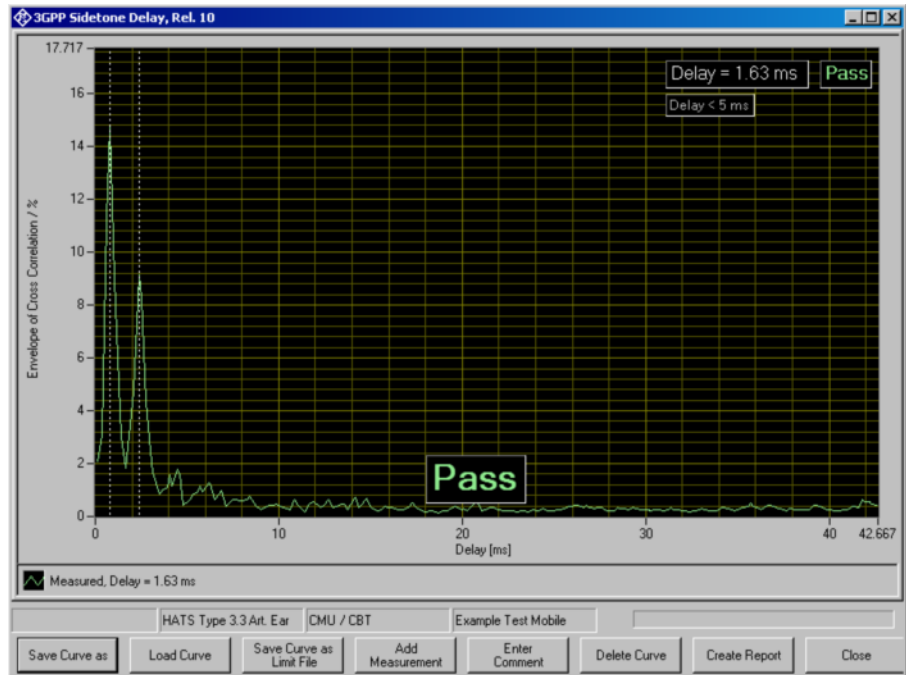

Fig. 125 Typical sidetone delay result according to release 10

Mobile Station Delay

In TIA-1042-A the measurement of the roundtrip delay is required. The roundtrip delay is defined as the sum of the contributions of the UE under test to the uplink and downlink end-to-end delay. To obtain the roundtrip delay value, the end-to-end delay can either be measured separately for uplink and downlink, or the loopback delay can be measured by establishing a loopback of the voice data in the system simulator. In both cases the contribution of the system simulator has to be subtracted from the measured end-to-end delay. The method specified in TIA-1042-A is using the loopback in the network simulator.

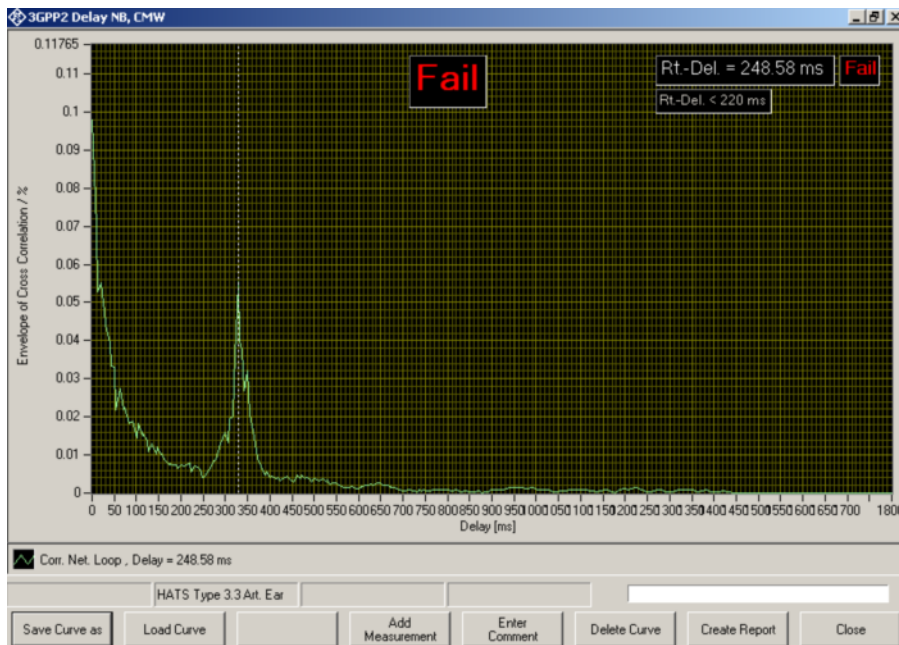

Fig. 126 Typical roundtrip delay result

The loopback delay is measured by cross-correlation between the generator output signal and the analyser input signal.

Test signal is a short word “five” of real speech according to ITU-T P.501.

Speech Quality in Presence of Ambient Noise

Setup

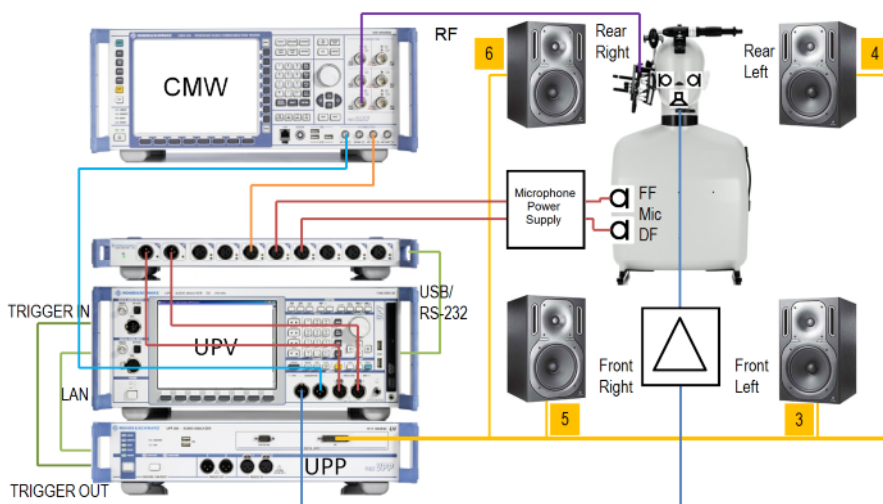

Fig. 127 Test setup and connection of external components with CMW500 and input switcher UPZ for measurement “Speech Quality in Presence of Background Noise”

The arrangement of the elements in the block schematic does not reflect the physical setup in the test room. See ETSI ES 202396-1 for details on

the requirements for the test room and the speaker setup. For the speaker positioning the following rules and advice apply:

- The four full-range speakers are to be arranged in a square
- Distance of each of the four full-range speakers from the center of the HATS is 2m
- Avoid positioning any speaker in any of the room corners
- Avoid positioning of speakers including subwoofer or HATS exactly in the room center or at one half, one third or one fourth of the room length or width

Connections

Connect

1. LAN socket of UPV to LAN socket of UPP
2. UPP trigger output to UPV trigger input
3. UPP-Z8A output 3 to input of front left active speaker
4. UPP-Z8A output 4 to input of rear left active speaker
5. UPP-Z8A output 5 to input of front right active speaker
6. UPP-Z8A output 6 to input of rear right active speaker
7. UPP-Z8A configured subwoofer output (by default 7) to input of active subwoofer
8. UPV generator output 1 to artificial mouth via drive amplifier
9. Artificial ears to microphone power supply during noise field calibration
10. During the acquisition for the speech quality evaluation, a ¼" microphone is connected to UPV analyzer input 1 via the microphone power supply
11. Output 1 of the CMU / CMW to UPV analyzer input 2.

Switcher Support

If 'Input Switcher UPZ' is enabled in 'Noise Calibration Configuration', the measurement will try to connect all required signal sources automatically to UPV input instead of prompting user to change cabling. This presumes:

- UPV is connected to UPZ via serial cable (RS232) **OR** USB cable (do not connect USB if you want to use RS232!);
- USB-to-serial device driver is installed (only if using USB connection);
- UPZ is powered ON (green 'ON'-LED on switcher front panel)

When starting the measurement the first time, a dialogue is displayed to instruct the user how to connect the input switcher's analogue input and output connections (note: only 1 microphone needs to be connected to input channel 4 or 5, respectively):

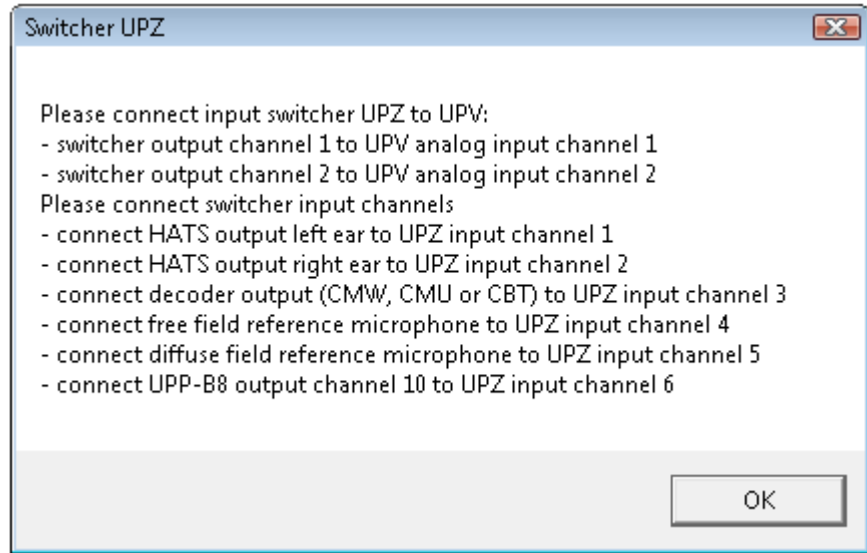

Fig. 128 Switcher support, analogue connection instructions.

or – if no switcher could be detected – how to establish the control connection from UPV to UPZ:

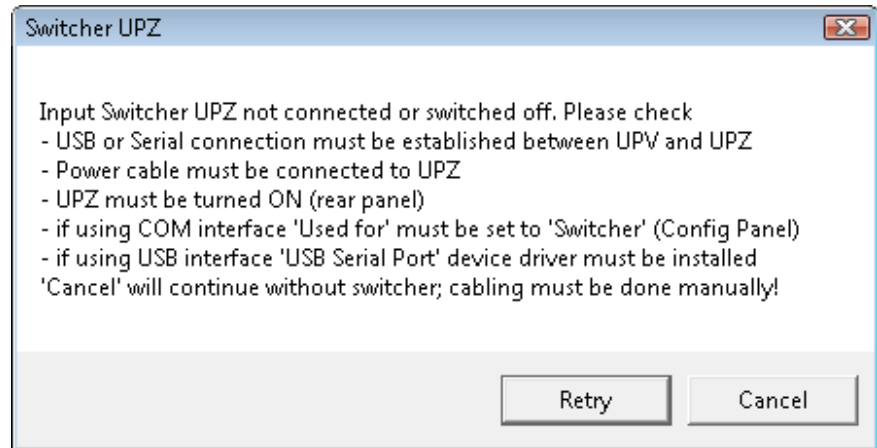

Fig. 129 Switcher support, control connection instructions.

If the switcher cannot be enabled at this point, then "Cancel" will disable switcher for the current measurement. The cabling has to be done manually. The corresponding setting in configuration window will not be changed. On next start of this measurement it will again be attempted to use the switcher.

The measurement checks the connection to UPZ whenever the switcher needs to be operated. If switcher control fails while measurement is running (e.g. by unplugging the control or power cable), the operator will be prompted to establish the analogue connections manually. This allows the measurement to continue correctly.

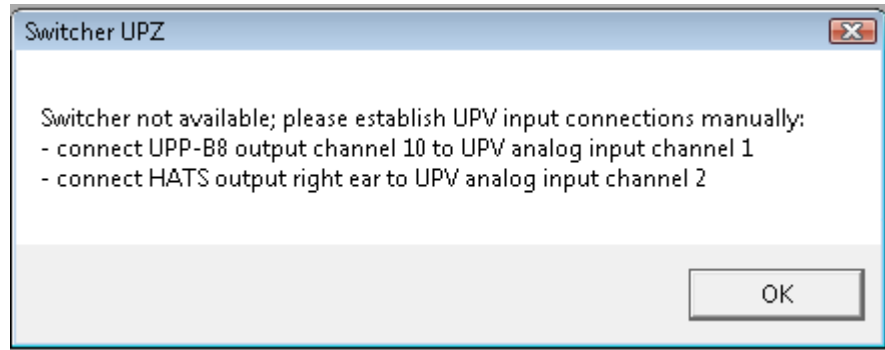

Fig. 130 Switcher support, error message if switcher failed during measurement.

Prerequisites

- Reference Microphone Calibration
- Artificial Mouth Calibration
- Codec Calibration
- Noise Field Calibration

Measurement

Place the reference microphone close to the opening of the UE's main microphone.

Start the test case from the "Measurement" or "Standard" menu. The test will start right away in the following processing order:

1. For each ambiance, measurement of uplink delay and checking if established call still is alive
2. For each ambiance, recording the raw signals
3. For each ambiance, checking again if established call still is alive
4. Pre-processing all recordings for calculation
5. Processing of the acquired signals with simultaneous display of the results according to the progress, including the "PASS/FAIL" criteria.
6. Deleting of temporary files.

A typical image showing the completion of steps 1-3 looks like following:

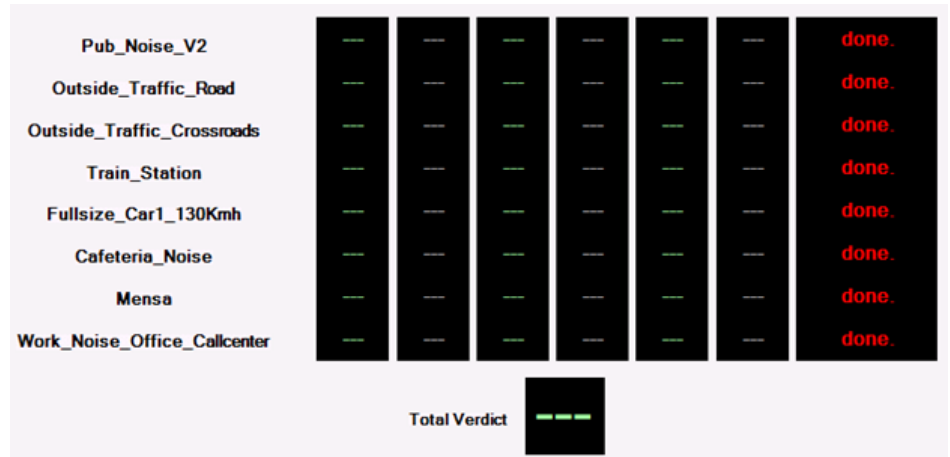

Fig. 131 Running “Speech Quality in Presence of Background Noise” – all recordings are just done

Each recording resp. calculation can be repeated by clicking “Repeat current sequence” in the status box:

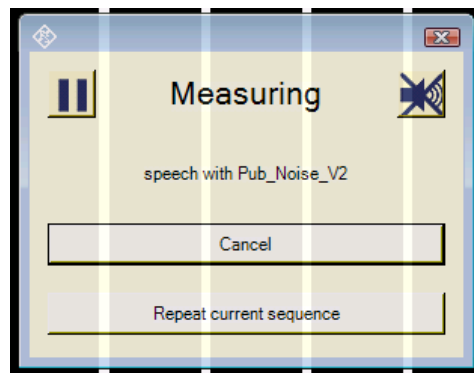

Fig. 132 Busy message of “Speech Quality in Presence of Background Noise” with Pause, Emergency Off, Cancel, Repeat

The “cancel” button cancels the complete measurement.

The “repeat ... sequence” button repeats the current step. This may be a delay measurement, a recording of a specific noise ambiance or its calculation.

The “crossed speaker” symbol button stops the playback of the noise and test signal and aborts the current acquisition which can be repeated thereafter.

The “pause” button symbol suspends execution and shows a message box which will allow cancelling or continuing the measurement:

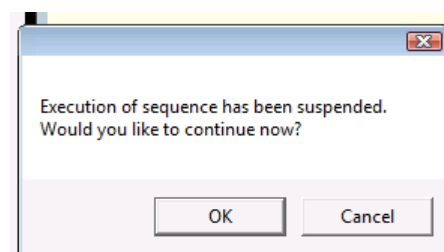

Fig. 133 Message after the measurement execution has been suspended

When all recordings are done, the calculation process starts. For each ambiance, the 3QUEST batch calculator will be started with the preprocessed recordings.

Results are S-MOS, N-MOS and G-MOS for each ambiance and overall average. The coloured values are the averages over all sentences, and the grey values are the standard deviations between the sentences.

Depending of the predefined PASS / FAIL criteria, the result values will be coloured in green or red. The total verdict is “Fail” if the average of all S-MOS-LQO is below 3.0 or the average of all N-MOS-LQO is below 2.5 or the average of all G-MOS-LQO is below 2.5.

Continuing broken Measurements

When a measurement has been cancelled by “Cancel” for some reason and the “Speech Quality in Presence of Ambient Noise” window has been closed, there is a possibility of recovering the already existing recording within 1 hour after abortion of the measurement.

When opening the measurement window again, the software will try to find the raw data for each ambiance signal which has been recorded during the last hour with exact the same settings like the current.

If raw data is found, the software will ask the user to reuse it for each ambiance:

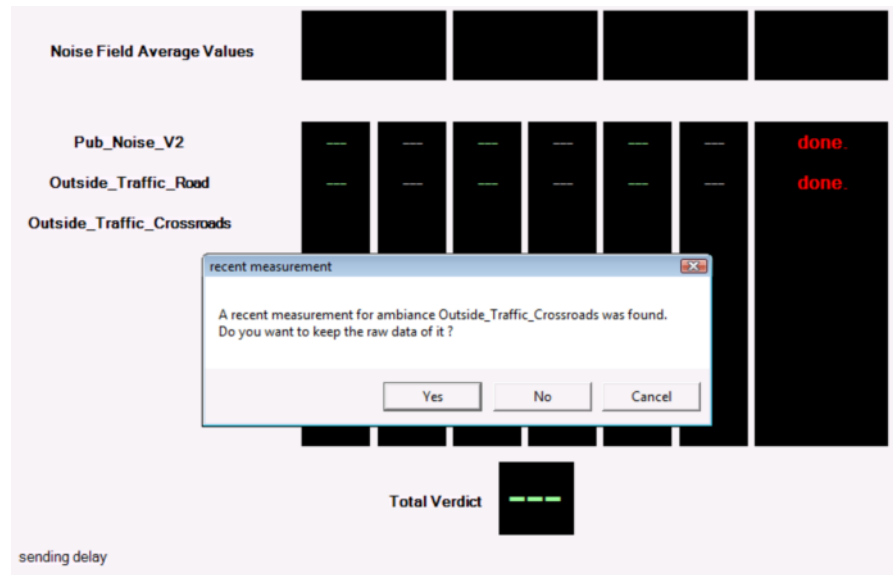

Fig. 134 Recovering raw data from last “Speech Quality in Presence of Background Noise” measurement

Typical Problems during measurement

In practice it can happen that a mobile under test drops the call after a few minutes.

Since the recording of the signals takes a quite long time and often runs without supervision, the software contains a security check if the call still is alive:

1. Before any recording will be started, the current signal delay and signal level is detected. If the signal level is below a lower limit, the measurement stops and allows a retry.
2. After a recording is done the signal level is detected again. If the level is below a lower limit, the measurement stops, too.

In both cases following message box appears:

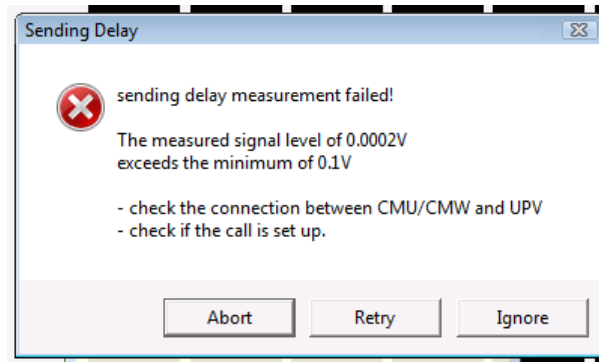

Fig. 135 Common Problem 1: “Speech Quality in Presence of Background Noise” detected lost call

“Retry” will repeat the current noise ambiance measurement (e.g. after resetting the call), “Ignore” will skip this measurement and continue with the next one (e.g. during a demo if the result does not matter), “Abort” will cancel the measurement.

A second problem may occur when the recordings are all done and the calculation process is started: The 3QUEST does not find its license. This typically would look like this:

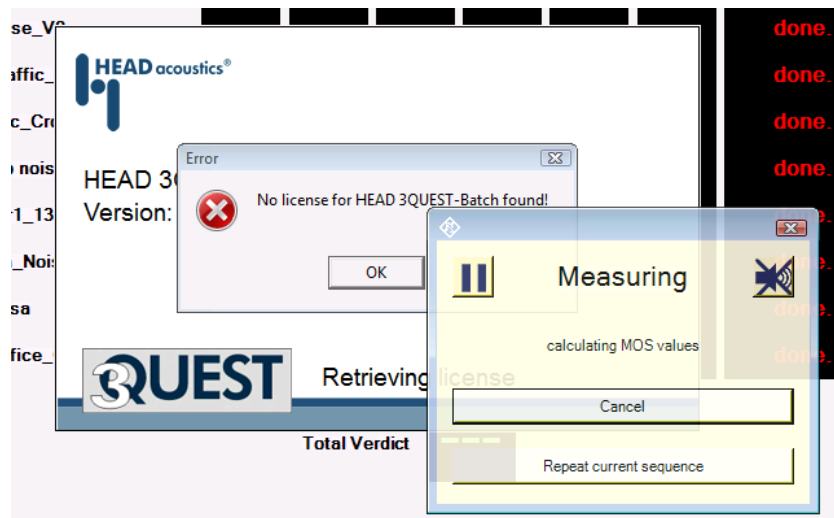

Fig. 136 Common Problem 2: “Speech Quality in Presence of Background Noise” running 3QUEST with missing License dongle

There may be two reasons for it:

1. The 3QUEST license dongle is missing on the UPV

2. The UPV is being operated remotely with Microsoft Remote Desktop while the dongle is plugged in.

In both cases the user may either press the “Cancel” button in the yellow progress window or he may quit the 3QUEST license message.

Additional operations when finished

When the noise measurement is completely finished, there are some extended features which may be reached through the soft key bar:



Fig. 137 The soft key tool bar of the “Speech Quality in Presence of Background Noise” measurement

Verify Delay	Takes a single delay measurement of the current call
Verify Noise Field	Checks the sound pressure level of each ambiance according to the specification. For this measurement, both artificial ears are used.
Verify Speech Level	Checks the sound pressure level of the artificial mouth according to the specification. For this measurement, the reference microphone must be placed to the HATS MRP.
Repeat Measurement	Repeats the complete measurement
Enter Comment	Allows to enter an additional comment for the report.
Clear Temp Files	Normally, the intermediate files belonging to a specific noise field calibration will not be removed. This button allows to clear all temporary files to get more space on the hard disk. The files will be recreated automatically during next measurement – but this will take some more time.
Create Report	Allows direct creation of a report

Extended Speech Quality Measurements

In addition to the normative Speech Quality Measurements, R&S provides some extra functionality which can be reached across the Menu. It is called “Extended Speech Quality in Presence of Ambient Noise”

When the extended version of the background noise measurement is started, it will be possible to measure only a subset of the given signals and to repeat a single signal as well. This is done by using the additional check boxes in the window. Only for checked ambiances the recordings and calculations will be done.

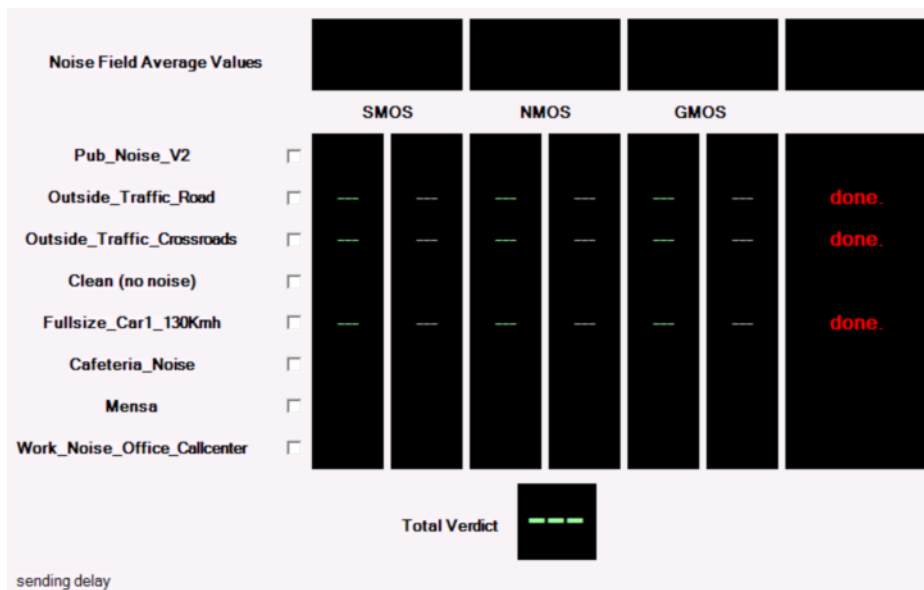

Fig. 138 Running “Extended Speech Quality in Presence of Background Noise” with only 3 ambiances: Recording is just done.

In this example, the steps 1-3 of only three selected signals has just been performed before the calculation starts.

Continuing broken Extended Measurements

In addition to the recovery functionality of already recorded raw signals, the extended mode provides recovery of calculations already done, too:

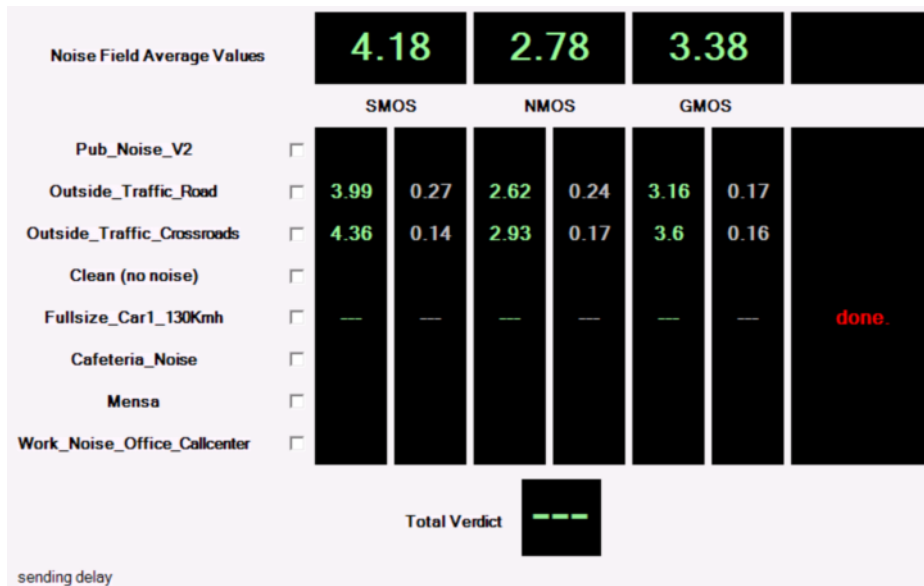

Fig. 139 Restarting “Extended Speech Quality in Presence of Background Noise” with only 3 ambiances: The first two ambiances have been calculated, now recording of third ambiance is just done.

This image shows a recovery situation after two ambiances have been calculated and a third one had been added. The calculation of the third one has not been done yet. When reopening, the check marks of “Clean (no noise)”, “Cafeteria”, “Mensa” and “Callcenter” had been set automatically again but were removed by the user.

When “Repeat Measurement” is clicked now, nothing will happen except that the calculation of the missing ambient noise will be done. A typical final result will show like this:

Noise Field Average Values		4.27		2.81		3.48		PASS	
		SMOS		NMOS		GMOS			
Pub_Noise_V2	<input type="checkbox"/>								
Outside_Traffic_Road	<input type="checkbox"/>	3.99	0.27	2.62	0.24	3.16	0.17	PASS	
Outside_Traffic_Crossroads	<input type="checkbox"/>	4.36	0.14	2.93	0.17	3.6	0.16	PASS	
Clean (no noise)	<input type="checkbox"/>								
Fullsize_Car1_130Kmh	<input type="checkbox"/>	4.47	0.07	2.86	0.08	3.67	0.11	PASS	
Cafeteria_Noise	<input type="checkbox"/>								
Mensa	<input type="checkbox"/>								
Work_Noise_Office_Callcenter	<input type="checkbox"/>								
								Total Verdict	

sending delay

Fig. 140 Completed “Extended Speech Quality in Presence of Background Noise” measurement

In a recovery situation, there also would be the ability for adding new noise ambiances. The condition between each check mark and current display decides what exactly will happen:

- If a check mark is set, the corresponding noise ambiance will be recorded and calculated again no matter if already a raw data set exists or not.
- If a check mark is cleared, the corresponding noise ambiance will never be recorded again. If there is still a result, nothing will happen. Otherwise, if there exists a raw data set, the calculation will be performed.

Notes on Hands-Free Measurements

General Remarks

The standards 3GPP2 C.S0056, 3GPP2 C.S0056-A, TIA-1042 and TIA-1042-A do not define requirements and test specifications for the tests of the acoustic behaviour of the mobile phone in this mode

As bonus, R&S UPV-K92 CDMA2000[®] Mobile Phone tests provide test cases for handheld hands-free and desktop hands-free mode with narrow band and wideband speech. The method and requirements are analogous to those in 3GPP TS 26.132. Test specifications and limits for hands free car kits are the same as for desk top hands-free terminals.

Hands-free tests with R&S UPV-K92 support the use of either artificial mouth according to ITU-T P.51 together with a free field measurement microphone or alternatively the use of a HATS with type 3.3 or 3.4 artificial ear and artificial mouth according to ITU-T P.58.

Test Setup

All tests must be performed in an anechoic room. Background noise must be less than 24 dB SPL(A). Furthermore the room should be big enough and its walls should have sufficient absorption to provide nearly free-field conditions at the hands-free reference point. Not all test boxes which are appropriate for handset tests can be used for hands free measurements.

If a free-field microphone with a discrete P. 51 mouth is used, it should be configured to the Handheld hands-free UE as per Figure 58 for receiving measurements and Figure 59 for sending measurements. The measurement instrument should be located at a distance d_{HF} from the centre of the visual display of the mobile station. The distance d_{HF} is specified by the manufacturer.

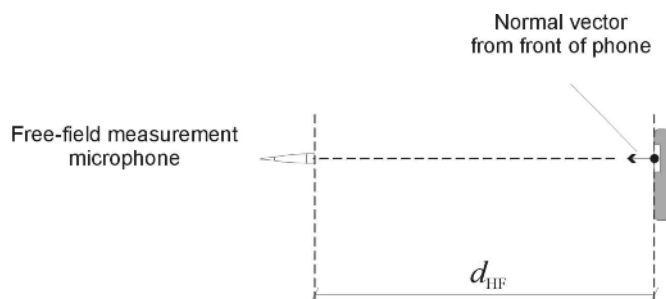

Fig. 141 Configuration of handheld hands-free UE, free-field microphone for receiving measurements

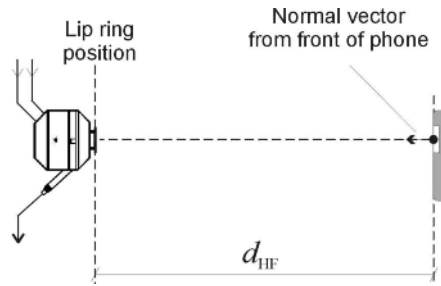

Fig. 142 Configuration of handheld hands-free UE and artificial mouth according to ITU-T P.51 for sending measurements

If a HATS is used, the measurement can either be performed binaurally (with two artificial ears and correction of the RLR by 6 dB) or monaural.

The selection of acoustic accessories used for the hands free tests can be entered in menu item "Options → Hands free settings".

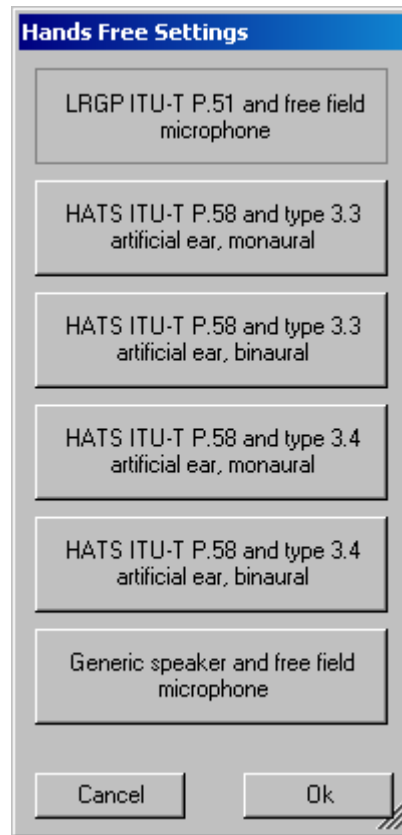

Fig. 143 Hands free settings

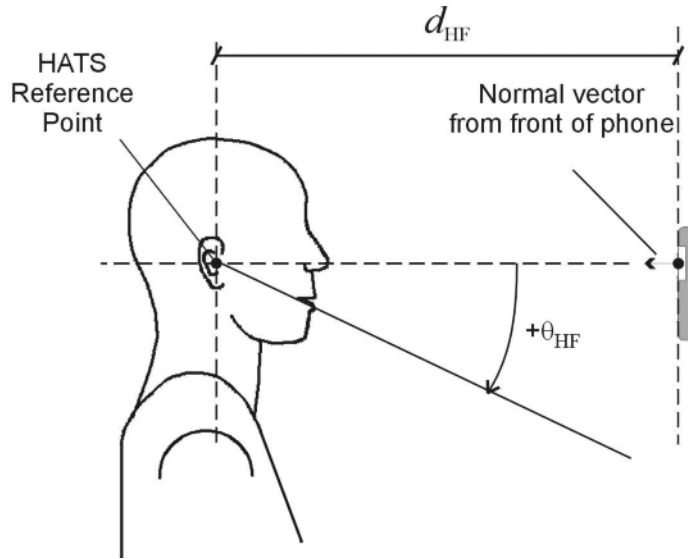

Fig. 144 Configuration of handheld hands-free UE with HATS

For desk top hands-free it is referred to ITU-T P. 340 (<http://www.itu.int>) for the use of free field microphone and discrete P.51 mouth. The hands free terminal should be placed on a table of approximately 1 m² with the centre of its front edge 400 mm perpendicularly from the centre of the front edge of the table. The surface area should not be less than 0.96 m² and its width should not be less than 0.8 m. The front centre of the measuring microphone or centre of the lip ring, respectively, should be placed 300 mm above the centre of the front edge of the table with the axis of the microphone or artificial mouth inclined towards the centre of the front edge of the hands-free terminal.

For the use of a HATS with both types of hands-free terminals it is referred to ITU-T P.581. For handheld hands free the setup of ITU-T P.581 corresponding to “portable hands-free” should be used. For desk top hands-free, the centre of the lip ring is positioned as described above, but the axis of the artificial mouth should be horizontal.

Acoustic Calibration for Hands Free Tests

The calibration for the free field microphone or type 3.3 or type 3.4 HATS ear, respectively, is done as described in chapter 4 above.

For binaural measurements, the second artificial ear has to be calibrated accordingly, using the sub-item “Second Type 3.3 ear” or “Second type 3.4 ear”, respectively, in “Calibration → Artificial Ear”. Note that the second artificial ear must be connected to Analyzer input 2 instead of the R&S CMU200 connection.

According to 3GPP TS 26.132, free field equalization has to be taken into account. Free field data can either be imported as an average table from the standard or from an individual calibration disk, using the menu item “Calibration → Free field equalization”.

The calibration of the artificial mouth for hands free tests comprises two additional steps. After the level has been adjusted and the frequency response has been equalized at the MRP, the reference microphone has to be repositioned at the so-called Hands-Free Reference Point (HFRP or HATSHFRP).

For the mouth according to ITU-T P.51 the HFRP is in 50 cm distance from the lip ring on the axis of the mouth. The calibration has to be performed at this point independent of the measuring distance currently used.

The HATS HFRP is stipulated in ITU-T P.581. It is one of the points 11 to 17 defined in table 6a of ITU-T P.58. It should be on the axis which is closest to the actual axis from the lip ring to the microphone under test. The distance is always 50 cm from the lip ring. The axis may be azimuthally centric (i.e. 0° horizontally) with an elevation (vertical) angle of 0° , $\pm 15^\circ$ or $\pm 30^\circ$. Points 16 and 17 are located on an axis with 0° elevation and an azimuth angle of 15° or 30° .

The level at this point is adjusted to -28.7 dBPa. For the last step, the reference microphone is returned to the MRP, and the level and spectrum at the MRP are measured as reference for the transfer function calculation.

The mouth calibration for hands-free tests is started with the menu item "Calibration → Artificial Mouth (Hands Free)". This procedure comprises the mouth calibration for handset tests and has also effect on subsequent handset tests with the same individual artificial mouth.

Customizing Measurements

The first item in the “Measurement” menu which is called “Settings” opens a sub-menu with all available measurements in it. Clicking on a measurement in this sub-menu opens a window which allows to change parameters of the selected measurement.

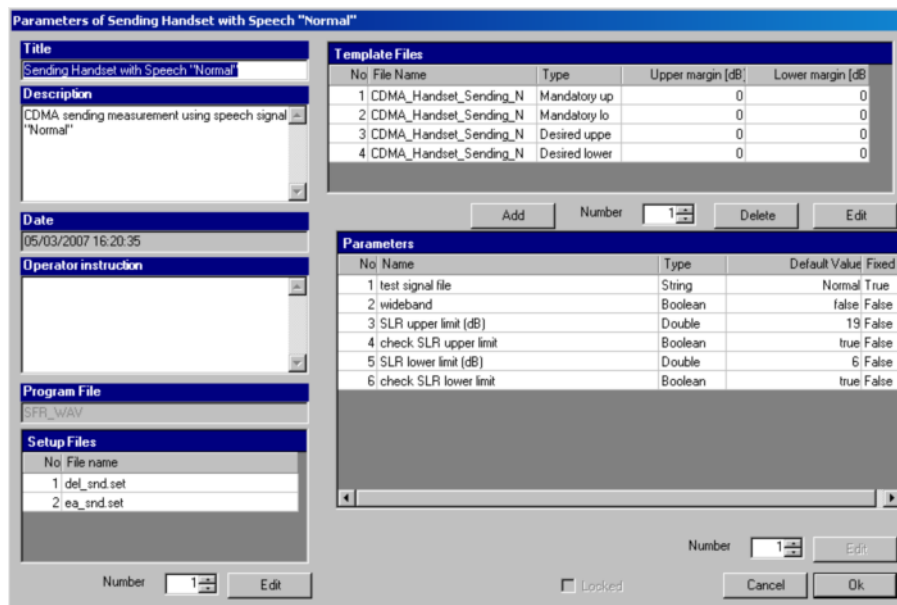

Fig. 145 Measurement setup window

The “Title” appears in the measurement menu and forms the heading of the report.

The “Description” can be chosen to be included into the report.

“Date” shows the date of the last change to this measurement definition.

“Operator instruction” is the text displayed before the start of each measurement, provided that the item “Show operator instructions” is activated in the “Options” menu.

The entry in the field “Program File” designates the measurement type and must not be changed.

The field “Setup Files” specifies the R&S UPV setups used by the measurement. The specified file can be replaced by a user defined file but the number of setups is defined by the measurement type. The customized setup file must be stored in folder D:\Hearing. It is recommended to generate customized setups by copying existing ones. Note that changes in the setup like changing the analysis function or generator signal may cause malfunction of the measurement. Some parameters of the setup might be overwritten by the macro during the measurement run.

The field “Template files” specifies limit template curves for the response curve. The buttons “Add” or “Edit” produce the following input window:

Fig. 146 Input window for limit template curve

The radio buttons allow to determine whether the given curve should be used as upper limit, lower limit or for information only (no limit check). The field "File name" must contain the path name of the file. To generate a new limit curve file, use the softkey "Save as limit curve" of the respective measurement window or copy and edit an existing limit file using a text editor.

All other available parameters of a measurement definition are shown in the "Parameters" data grid. The rightmost column with the headline "Fixed" displays whether the respective parameter can be changed by the operator or not. In "generic" measurements all parameters may be changed. In measurements which follow standards, only parameters which are not determined by the standard may be changed by the operator. The "Edit" button opens an input window for the parameter in the line specified in "Number":

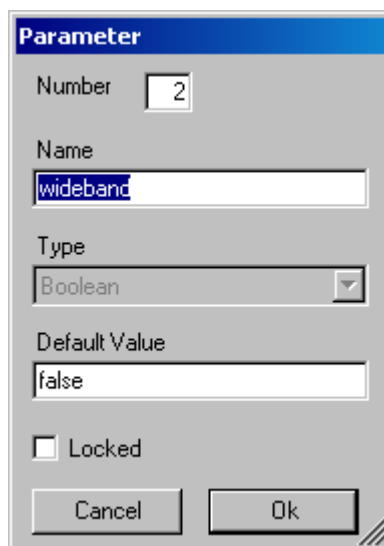

Fig. 147 Input window for parameter value

“Name” appears in the report and explains the meaning of the parameter. “Type” is determined by the measurement routine and cannot be changed. In the field “Value” a value must be entered which conforms with the syntax rules of the selected data type. The syntax is checked automatically when the text box is left. However there is no check for the allowable range of the value. Entering inadequate values (e.g. too high levels, negative frequencies) may cause malfunction of the measurement.

Parameters for the different Measurement Types

Sending Response

Table 7 Parameters for sending response measurements

Name	Type	Value	Explanation
test signal file	String	Normal	The file cannot be changed by the operator
wideband	Boolean	false	Do not change
SLR upper limit (dB)	Double	19	Upper limit for SLR limit check
check SLR upper limit	Boolean	true	Upper limit is checked if “true”
SLR lower limit (dB)	Double	6	Lower limit for SLR limit check
check SLR lower limit	Boolean	true	Lower limit is checked if “true”

Sending Response AMPS

Table 8 Parameters for sending response measurements in AMPS

Name	Type	Value	Explanation
test signal file	String	Normal	Cannot be changed by the operator
wideband	Boolean	false	Do not change
SLR upper limit (dB)	Double	19	Upper limit for SLR limit check
SLR check upper	Boolean	false	Upper limit is checked if “true”
SLR lower limit (dB)	Double	19	Lower limit for SLR limit check
SLR check lower	Boolean	false	Lower limit is checked if “true”
loudness contrast limit (dB)	Double	3	Limit for absolute SLR difference between CDMA2000 and AMPS
check loudness contrast	Boolean	true	Limit is checked if “true”

Sending Response with Speech “Single Talk”

Table 9 Parameters for sending response measurements with ST speech

Name	Type	Value	Explanation
CDMA	Boolean	True	Defines 0 dBFS = 3.17 dBm0
signal file name	String	ST_100-8000Hz_FS	The file cannot be changed by the operator
analysis delay (s)	Double	0	Start of the analysis after start of the signal
analysis length (s)	Double	35.4116	Length of the analysed portion of the signal
selective	Boolean	False	Time-selective analysis of the spectrum
handsfree	Boolean	False	Use devices configured in handsfree settings
wideband	Boolean	False	Speech codec bandwidth
annex G weighting factors	Boolean	False	False: Use Annex A of P.79 True: Use Annex G of P.79
SLR upper limit (dB)	Double	11	Upper limit for SLR limit check
check SLR upper limit	Boolean	True	Upper limit is checked if “true”
SLR lower limit (dB)	Double	5	Lower limit for SLR limit check
check SLR lower limit	Boolean	True	Lower limit is checked if “true”

Receiving Response

Table 10 Parameters for receiving response measurements

Name	Type	Value	Explanation
test signal file	String	Normal	The file cannot be changed by the operator
DRP	Boolean	false	If “false”, the DRP-ERP correction is taken into account
Wideband	Boolean	false	Selects wideband measurement (100 Hz to 7 kHz). Not available in the current version.
RLR upper limit (dB)	Double	5	Upper limit for RLR limit check
RLR check upper	Boolean	true	Upper limit is checked if “true”
RLR lower limit (dB)	Double	-5	Lower limit for RLR limit check
RLR check lower	Boolean	true	Lower limit is checked if “true”

Receiving Response AMPS

Table 11 Parameters for receiving response measurements in AMPS

Name	Type	Value	Explanation
test signal file	String	Normal	The file cannot be changed by the operator
DRP	Boolean	false	If “false”, the DRP-ERP correction is taken into account
wideband	Boolean	false	Do not change
RLR upper limit (dB)	Double	5	Upper limit for RLR limit check
RLR check upper	Boolean	false	Upper limit is checked if “true”
RLR lower limit (dB)	Double	-5	Lower limit for RLR limit check
RLR check lower	Boolean	false	Lower limit is checked if “true”
max. loudness contrast (dB)	Double	3	Limit for absolute RLR difference between CDMA2000 and AMPS
check loudness contrast	Boolean	true	Limit is checked if “true”

Receiving Response with Speech "Single Talk"

Table 12 Parameters for receiving response measurements with ST speech

Name	Type	Value	Explanation
CDMA	Boolean	True	Defines 0 dBFS = 3.17 dBm0
signal file name	String	ST_100-8000Hz_FS	The file cannot be changed by the operator
analysis delay (s)	Double	0	Start of the analysis after start of the signal
Analysis length (s)	Double	35.4116	Length of the analysed portion of the signal
selective	Boolean	False	Time-selective analysis of the spectrum
handsfree	Boolean	False	Use devices configured in handsfree settings
Binaural	Boolean	False	Binaural measurement for binaural headsets
curve equalisation	String	DF	Equalisation applied to frequency response
loudness rating equalisation	String	ERP	Equalisation applied to loudness rating calculation
wideband	Boolean	True	Speech codec bandwidth
annex G weighting	Boolean	False	False: Use Annex A of P.79 True: Use Annex G of P.79
RLR upper limit	Double	5	Upper limit for SLR limit check
check RLR upper limit	Boolean	True	Upper limit is checked if "true"
RLR lower limit	Double	-1	Lower limit for SLR limit check
check RLR lower limit	Boolean	True	Lower limit is checked if "true"

Loudness Rating Contrast Calculation

Table 13 Parameters loudness rating contrast calculation

Name	Type	Value	Explanation
compared value count	Parameter count	2	Must be the same in all instances
measurement testcase title (1)	String	Sending Handset WB with Speech "Single Talk"	Exact name of first WB testcase
measurement testcase title (2)	String	Receiving Handset WB with Speech "Single Talk"	Exact name of second WB testcase
compared value count	Parameter count	2	
measurement value name (1)	String	Sending Loudness Rating	Exact name of first WB value
measurement value name (2)	String	RLR	Exact name of second WB value
compared value count	Parameter count	2	
reference testcase title (1)	String	Sending Handset NB with Speech "Single Talk"	Exact name of first NB testcase
reference testcase title (2)	String	Receiving Handset NB with Speech "Single Talk"	Exact name of second NB testcase
compared value count	Parameter count	2	
reference value name (1)	String	Sending Loudness Rating	Exact name of first NB value
reference value name (2)	String	RLR	Exact name of second NB value
compared value count	Parameter count	2	
contrast value name (1)	String	Contrast Sending	Name of the first result in the report
contrast value name	String	Contrast Receiving	Name of the second

Acoustic Measurements on Mobile Phones

Name	Type	Value	Explanation
(1)			result in the report
compared value count	Parameter count	2	
upper limit (1) [dB]	Double	3	Upper limit for first result
upper limit (2) [dB]	Double	3	Upper limit for second result
compared value count	Parameter count	2	
check upper limit (1)	Boolean	True	Upper limit is checked on first result if "true"
check upper limit (2)	Boolean	True	Upper limit is checked on second result if "true"
compared value count	Parameter count	2	
lower limit (1) [dB]	Double	-3	Lower limit for first result
lower limit (2) [dB]	Double	-3	Lower limit for second result
compared value count	Parameter count	2	
check lower limit (1)	Boolean	True	Lower limit is checked on first result if "true"
check lower limit (2)	Boolean	True	Lower limit is checked on second result if "true"
maximum value age (hours)	Double	0.5	Found values are only used if they are younger than specified here
store additional information as comment	Boolean	True	Retrieved values are stored as comment

Terminal Coupling Loss

Table 14 Parameters for TCL measurements

Name	Type	Value	Explanation
signal file name	String	Echoloss	The file cannot be changed by the operator
rms value (dBFS)	Double	-12.5	Rms value of the signal file, cannot be changed by the operator
wideband	Boolean	false	Selects wideband measurement (100 Hz to 7 kHz). Not available in the current version.
TCL upper limit (dB)	Double	0	Upper limit for TCL limit check
check upper limit	Boolean	false	Upper limit is checked if "true"
TCL lower limit (dB)	Double	45	Lower limit for TCL limit check
check lower limit	Boolean	true	Lower limit is checked if "true"

Terminal Coupling Loss with Compressed Speech "Single Talk"

Table 15 Parameters for TCL with compressed ST speech

Name	Type	Value	Explanation
CDMA	Boolean	True	Defines 0 dBFS = 3.17 dBm0
Wideband	Boolean	False	Speech codec bandwidth
Handsfree	Boolean	False	Use devices configured in handsfree settings
Signal File	String	ST_compressed_NB	The file cannot be changed by the operator
act. level to peak ratio [dB]	String	-17.873	Property of the test signal file
signal level (dBm0)	Double	-10	Level of the test signal at the encoder input

Acoustic Measurements on Mobile Phones

Name	Type	Value	Explanation
pre-delay (s)	Double	17	Start of the analysis after start of the signal
analysis length (s)	Double	18	Length of the analysed portion of the signal
selective	Boolean	False	Time-selective analysis of the spectrum
max. age of delay values [hrs]	Double	0.5	Not used
TCL upper limit (dB)	Double	80	Upper limit for TCL limit check
check TCL upper limit	Boolean	False	Upper limit is checked if "true"
TCL lower limit (dB)	Double	45	Lower limit for TCL limit check
check TCL lower limit	Boolean	True	Lower limit is checked if "true"
show noise curve	Boolean	True	Show spectrum of second measurement without test signal

Peak Acoustic Level

Table 16 Parameters for peak acoustic level measurements

Name	Type	Value	Explanation
test signal file name	String	PeakLevel	File name (without extension) of the .wav file used for the test
measurement interval (s)	Double	10	Length of the measurement
DRP	Boolean	false	If "false", the DRP-ERP correction is taken into account
upper limit (dBPa)	String	42	Upper limit for sound pressure level in dBPa
check upper limit	Boolean	true	Upper limit is checked if "true"

Sending Noise

Table 17 Parameters for sending noise measurements

Name	Type	Value	Explanation
average count	Byte	10	Number of averaged measurements
upper limit [dBm0(P)]	Double	-64	Upper limit noise level limit check
check upper limit	Boolean	true	Upper limit is checked if "true"
lower limit [dBm0(P)]	Double	-100	Lower limit for noise level limit check
check lower limit	Boolean	false	Lower limit is checked if "true"
weighted spectrum	Boolean	true	If "true", the displayed spectrum is weighted, if "false", the spectrum is unweighted
store spectrum	Boolean	true	If "true", the spectrum is stored for reporting

Sending Noise with Activation Signal

Table 18 Parameters for sending noise test with activation signal

Name	Type	Value	Explanation
weighting filter	String	CCIT	Can be CCITT or AWE
handsfree measurement	Boolean	False	Use devices configured in handsfree settings
lower frequency (Hz)	Double	300	Lower end of analysis frequency range
upper frequency (Hz)	Double	3400	Upper end of analysis frequency range
use activation signal	Boolean	True	Switch activation signal on/off
activation signal	String	CSS_Act_48kHz	If no signal is specified, the activation signal specified in the "Options" menu is used
activation signal level (dBPa)	Double	-4.7	Level of the activation signal at MRP

Acoustic Measurements on Mobile Phones

Name	Type	Value	Explanation
adapt activation signal level	Boolean	False	Allow to reduce the level of the activation signal if it exceeds the generator range
measurement delay (ms)	Double	100	Start of the analysis after start of the signal
average count	Byte	5	Number of measurements to be averaged
show all spectra	Boolean	True	Show spectra of all measurements on the screen
store all spectra	Boolean	False	Show spectra of all measurements in the report
maximum spectral resolution	Integer	1024	Maximum number of frequency points in the spectrum curves (has no influence on the FFT size!)
total noise upper limit (dBm0)	Double	-64	Upper limit for total noise rms
check total upper limit	Boolean	True	Upper limit is checked if "true"
lower limit for total noise (dBm0)	Double	-90	Lower limit can be applied to exclude dropped call
check total lower limit	Boolean	False	Lower limit is checked if "true"
upper limit for spectrum (dBm0)	Double	-74	Upper limit for single frequency disturbances
check spectral upper limit	Boolean	False	Check upper limit for single frequency disturbances
lower limit for spectrum (dBPa)	Double	-100	Lower limit can be applied to exclude dropped call
check spectral lower limit	Boolean	False	Lower limit is checked if "true"

Receiving Noise

Table 19 Parameters for receiving noise measurements

Name	Type	Value	Explanation
DRP	Boolean	false	If "false", the DRP-ERP correction is taken into account
average count	Byte	10	Number of averaged measurements
upper limit [dBPa(A)]	Double	-57	Upper limit for noise level limit check
check upper limit	Boolean	true	Upper limit is checked if "true"
lower limit [dBPa(A)]	Double	-100	Lower limit for noise level limit check
check lower limit	Boolean	false	Lower limit is checked if "true"
A weighted spectrum	Boolean	true	If "true", the displayed spectrum is weighted, if "false", the spectrum is unweighted
store spectrum	Boolean	true	If "true", the spectrum is stored for reporting
CDMA	Boolean	true	Adapts the timing of the test for the CDMA2000 codecs

Receiving Noise with Activation Signal

Table 20 Parameters for receiving noise test with activation signal

Name	Type	Value	Explanation
ear equalisation	String	DF	Equalization of the artificial ear (DRP, ERP, DF or FF)
weighting filter	String	AWE	Can be CCITT or AWE
handsfree measurement	Boolean	False	Use devices configured in handsfree settings
lower frequency (Hz)	Double	100	Lower end of analysis frequency range
upper frequency (Hz)	Double	10000	Upper end of analysis frequency range
use activation signal	Boolean	True	Switch activation signal on/off

Acoustic Measurements on Mobile Phones

Name	Type	Value	Explanation
activation signal	String	CSS_Act_48kHz	If no signal is specified, the activation signal specified in the "Options" menu is used
activation signal level (dBm0)	Double	-16	Level of the activation signal at the encoder input
measurement delay (ms)	Double	100	Start of the analysis after start of the signal
average count	Byte	5	Number of measurements to be averaged
show all spectra	Boolean	True	Show spectra of all measurements on the screen
store all spectra	Boolean	False	Show spectra of all measurements in the report
maximum spectral resolution	Integer	1024	Maximum number of frequency points in the spectrum curves (has no influence on the FFT size!)
binaural measurement	Boolean	False	Binaural measurement for binaural headsets
total noise upper limit (dBPa)	Double	-57	Upper limit for total noise rms
check total upper limit	Boolean	True	Upper limit is checked if "true"
lower limit for total noise (dBPa)	Double	-70	Lower limit can be applied to exclude dropped call
check total lower limit	Boolean	True	Lower limit is checked if "true"
upper limit for spectrum (dBPa)	Double	-60	Upper limit for single frequency disturbances
check spectral upper limit	Boolean	False	Check upper limit for single frequency disturbances
lower limit for spectrum (dBPa)	Double	-100	Lower limit can be applied to exclude dropped call
check spectral lower limit	Boolean	False	Lower limit is checked if "true"

Sending Distortion

Table 21 Parameters for sending distortion measurements

Name	Type	Value	Explanation
wideband	Boolean	false	Selects wideband measurement (100 Hz to 7 kHz). Not available in the current version.
average count	Byte	10	Number of averaged measurements
number of levels	Parameter count	10	Number of test levels, equals number of level parameters given below
level 1 (dB relative to ARL)	Double	-35	
level 2 (dB relative to ARL)	Double	-30	
level 3 (dB relative to ARL)	Double	-25	
level 4 (dB relative to ARL)	Double	-20	
level 5 (dB relative to ARL)	Double	-15	
level 6 (dB relative to ARL)	Double	-10	
level 7 (dB relative to ARL)	Double	-5	
level 8 (dB relative to ARL)	Double	0	
level 9 (dB relative to ARL)	Double	5	
level 10 (dB relative to ARL)	Double	10	
CDMA	Boolean	true	Adapts the timing of the test for the CDMA2000 codecs

Sending Distortion with Activation Signal

Table 22 Parameters for sending distortion test with activation signal

Name	Type	Value	Explanation
weighting	String	CCITT	Can be CCITT or AWE
handsfree	Boolean	False	Use devices configured in handsfree settings
lower frequency boundary (Hz)	Double	200	Lower end of analysis frequency range
upper frequency boundary (Hz)	Double	4000	Upper end of analysis frequency range
test tone duration (ms)	Double	360	Duration of the sine tone
settling time (ms)	Double	50	Start of the analysis after start of the test tone
average count	Byte	5	Number of measurements to be averaged
use activation signal	Boolean	True	Switch activation signal on/off
activation signal	String	CSS_Act_48kHz	If no signal is specified, the activation signal specified in the "Options" menu is used
adapt activation signal to range	Boolean	True	Allow to reduce the level of the activation signal if it exceeds the generator range
sweep 1 frequency (Hz)	Double	1020	Test tone frequency for level sweep
number of levels	Parameter count	6	
level 1 (dBPa)	Parameter count	5	
level 2 (dBPa)	Double	0	
level 3 (dBPa)	Double	-4.7	
level 4 (dBPa)	Double	-10	
level 5 (dBPa)	Double	-15	
level 6 (dBPa)	Double	-20	
number of activation levels	Parameter count	6	Must be equal to number of levels
activation level 1 (dBPa)	Double	5	
activation level 2 (dBPa)	Double	0	
activation level 3 (dBPa)	Double	-4.7	
activation level 4 (dBPa)	Double	-10	
activation level 5 (dBPa)	Double	-15	
activation level 6 (dBPa)	Double	-20	
sweep 2 level (dBPa)	Double	-4.7	Test tone level for frequency sweep
sweep 2 activation level (dBPa)	Double	-4.7	Activation level for frequency sweep
number of frequencies	Parameter count	0	
show spectrum	Boolean	True	Show spectrum on the screen
memorize spectrum	Boolean	True	Store spectrum until the measurement is closed, to be viewed after completion of the test
maximum resolution	Integer	400	Maximum number of frequency points in the spectrum curves (has no influence on the FFT size!)

Receiving Distortion

Table 23 Available parameters for receiving distortion measurements

Name	Type	Value	Explanation
DRP	Boolean	false	
average count	Byte	5	Number of averaged measurements
number of levels	Parameter count	10	Number of test levels, equals number of level parameters given below
level 1 (dBm0)	Double	-45	
level 2 (dBm0)	Double	-40	
level 3 (dBm0)	Double	-35	
level 4 (dBm0)	Double	-30	
level 5 (dBm0)	Double	-25	
level 6 (dBm0)	Double	-20	
level 7 (dBm0)	Double	-15	
level 8 (dBm0)	Double	-10	
level 9 (dBm0)	Double	-5	
level 10 (dBm0)	Double	0	
upper SPL limit (dBPa)	Double	10	Highest SPL for which the distortion is displayed and checked in the first test run. Pushing "Add measurement" causes all levels to be measured and displayed
CDMA	Boolean	true	Adapts the timing of the test for the CDMA2000 codecs

Receiving Distortion with Activation Signal

Table 24 Parameters for receiving distortion test with activation signal

Name	Type	Value	Explanation
equalization	String	DF	Equalization of the artificial ear (DRP, ERP, DF or FF)
weighting	String	CCITT	Can be CCITT or AWE
handsfree	Boolean	False	Use devices configured in handsfree settings
lower frequency boundary (Hz)	Double	100	Lower end of analysis frequency range
upper frequency boundary (Hz)	Double	6000	Upper end of analysis frequency range
test tone duration (ms)	Double	360	Duration of the sine tone
settling time (ms)	Double	50	Start of the analysis after start of the test tone
highest tested level (dBPa)	Double	10	Result is not checked if the measured level exceeds this value
average count	Byte	5	Number of measurements to be averaged
use activation signal	Boolean	True	Switch activation signal on/off
activation signal	String	CSS_Act_48kHz	If no signal is specified, the activation signal specified in the "Options" menu is used
adapt activation signal to range	Boolean	True	Allow to reduce the level of the activation signal if it exceeds the generator range
sweep 1 frequency (Hz)	Double	1020	Test tone frequency for level sweep
number of test tone levels	Parameter count	8	
test tone level 1 (dBm0)	Double	0	
test tone level 2 (dBm0)	Double	-3	

Acoustic Measurements on Mobile Phones

Name	Type	Value	Explanation
test tone level 3 (dBm0)	Double	-10	
test tone level 4 (dBm0)	Double	-16	
test tone level 5 (dBm0)	Double	-20	
test tone level 6 (dBm0)	Double	-30	
test tone level 7 (dBm0)	Double	-40	
test tone level 8 (dBm0)	Double	-45	
number of activation levels	Parameter count	8	Must be equal to number of levels
activation level 1 (dBm0)	Double	0	
activation level 2 (dBm0)	Double	-3	
activation level 3 (dBm0)	Double	-10	
activation level 4 (dBm0)	Double	-16	
activation level 5 (dBm0)	Double	-20	
activation level 6 (dBm0)	Double	-30	
activation level 7 (dBm0)	Double	-40	
activation level 8 (dBm0)	Double	-45	
sweep 2 test tone level (dBm0)	Double	-16	Test tone level for frequency sweep
sweep 2 activation level (dBm0)	Double	-16	Activation level for frequency sweep
number of frequencies	Parameter count	5	
frequency 1 (Hz)	Double	315	
frequency 2 (Hz)	Double	408	
frequency 3 (Hz)	Double	510	
frequency 4 (Hz)	Double	816	
frequency 5 (Hz)	Double	1020	Show spectrum on the screen
show spectrum	Boolean	True	Store spectrum until the measurement is closed, to be viewed after completion of the test
memorize spectrum	Boolean	True	Maximum number of frequency points in the spectrum curves (has no influence on the FFT size!)

Sidetone Masking Rating

Table 25 Available parameters for STMR measurements

Name	Type	Value	Explanation
DRP	Boolean	false	If "false", the DRP-ERP correction is taken into account
wideband	Boolean	false	Selects wideband measurement (100 Hz to 7 kHz). Not available in the current version.
STMR upper limit (dB)	Double	23	Upper limit for STMR limit check
check STMR upper limit	Boolean	true	Upper limit is checked if "true"
STMR lower limit (dB)	Double	13	Lower limit for STMR limit check
check STMR lower limit	Boolean	true	Lower limit is checked if "true"
CDMA	Boolean	true	Adapts the timing of the test for the CDMA2000 codecs

Sidetone Masking Rating with Speech "Single Talk"

Table 26 Parameters for STMR measurements with ST speech

Name	Type	Value	Explanation
signal file name	String	ST_100-8000Hz_FS	Cannot be changed by the operator

Acoustic Measurements on Mobile Phones

Name	Type	Value	Explanation
analysis delay (s)	Double	0	Start of the analysis after start of the signal
analysis length (s)	Double	35.4116	Length of the analysed portion of the signal
selective	Boolean	False	Time-selective analysis of the spectrum
curve equalisation	String	ERP	Equalisation applied to frequency response
STMR equalisation	String	ERP	Equalisation applied to STMR calculation
wideband	Boolean	True	Binaural measurement for binaural headsets
unsealed	Boolean	True	False: Apply leakage correction
LRGP method	Boolean	False	Enforce use of type 1 or type 3.2 ear
HATS method	Boolean	False	Enforce use of type 3.3 or type 3.4 ear
Autoselect	Boolean	False	False: Use Annex A of P.79 True: Use Annex G of P.79
binaural	Boolean	False	Binaural measurement for binaural headsets
STMR upper limit (dB)	Double	23	Upper limit for STMR limit check
check upper limit	Boolean	True	Upper limit is checked if "true"
STMR lower limit (dB)	Double	15	Lower limit for STMR limit check
check lower limit	Boolean	True	Lower limit is checked if "true"

Sidetone Delay with Cross-Correlation

Table 27 Parameters for sidetone delay tests with cross-correlation

Name	Type	Value	Explanation
test signal	String	CSS_48kHz	The file cannot be changed by the operator
signal level [dBPa]	Double	-4.7	SPL at MRP
initial delay [ms]	Double	49	Start of the analysis after start of the signal
correlation length [samples]	Integer	2048	Length of cross-correlation result
analysis length [ms]	Double	200	Length of cross-correlated signals
upper limit [ms]	Double	5	Upper limit for sidetone delay limit check
check limit	Boolean	True	Upper limit is checked if "true"
binaural measurement	Boolean	False	Binaural measurement for binaural headsets

Stability Margin

Table 28 Available parameters for stability margin tests

Name	Type	Value	Explanation
loop gain (dB)	Double	6	Specifies the gain applied between decoder output and encoder input for the stability test

Stability Loss

Table 29 Parameters for stability loss test

Name	Type	Value	Explanation
wideband	Boolean	True	Bandwidth of the speech codec
handsfree measurement	Boolean	False	Use devices configured in handsfree settings
play training sequence	Boolean	True	Switches training signal on/off

Acoustic Measurements on Mobile Phones

Name	Type	Value	Explanation
signal name	String	StabLossWB.arb	The file cannot be changed by the operator
act. level to peak ratio [dB]	Double	4.927	Property of the test signal file
signal level [dBm0]	Double	-3	Level of the test signal at the encoder input
pre-delay [ms]	Double	85	Start of the analysis after start of the signal
lowest measured frequency [Hz]	Double	100	Lower end of analysis frequency range
highest measured frequency [Hz]	Double	8000	Upper end of analysis frequency range
max. age of delay values [hrs]	Double	0.5	Not used
maximum spectral resolution	Integer	256	Maximum number of frequency points in the spectrum curves (has no influence on the FFT size!)
stability loss lower limit [dB]	Double	6	Lower limit for stability loss limit check
check stability loss lower limit	Boolean	True	Lower limit is checked if "true"
stability loss upper limit [dB]	Double	100	Upper limit for stability loss limit check
check stability loss upper limit	Boolean	False	Upper limit is checked if "true"
show noise curve	Boolean	True	Show spectrum of second measurement without test signal
training signal name	String	ST_100-8000Hz_FS	The file cannot be changed by the operator
act. level to peak ratio [dB]	Double	19.331	Property of the training signal file
training signal level [dBm0]	Double	-16	Encoder input level
CDMA	Boolean	True	Defines 0 dBFS = 3.17 dBm0

Delay Measurement with Cross-Correlation

Table 30 Parameters for the delay measurement with cross-correlation

Name	Type	Value	Explanation
test signal	String	five	The file cannot be changed by the operator
signal level 1 (dBPa)	Double	-4.7	SPL at MRP
signal level 2 (dBm0)	Double	-16	Encoder input level
initial delay (ms)	Double	0	Start of the analysis after start of the signal
correlation length (samples)	Integer	32768	Number of samples submitted to cross-correlation
analysis length (ms)	Double	1800	Length of cross-correlation result
undersample factor	Integer	4	Undersampling before cross-correlation
ignore initial peaks (ms)	Double	0	Suppression of sidetone for loopback on network side
minimum S/N factor	Double	1.2	Ratio between highest and second-highest cross-correlation peak
path	String	Nloop	Signal path (one of Mloop, Nloop, Rcv, Snd, Snd+Rcv)
CDMA	Boolean	True	Defines 0 dBFS = 3.17 dBm0
hands free	Boolean	False	Use devices configured in handsfree settings
binaural measurement	Boolean	False	For binaural headsets
store curves	Boolean	True	Show cross-correlation curves in the report
subtract roundtrip delay (ms)	Double	0	Delay contribution of system simulator
unused	Double	0	

Acoustic Measurements on Mobile Phones

Name	Type	Value	Explanation
snd delay upper limit (ms)	Double	60	
check snd delay upper limit	Boolean	False	
snd delay objective (ms)	Double	50	
check snd delay objective	Boolean	False	
rcv delay upper limit (ms)	Double	70	
check rcv delay upper limit	Boolean	False	
rcv delay objective (ms)	Double	55	
check rcv delay objective	Boolean	False	
roundtrip delay upper limit (ms)	Double	220	Upper limit for calculated roundtrip delay
check roundtrip delay upper limit	Boolean	True	Upper limit is checked if True
roundtrip delay objective (ms)	Double	185	Objective upper limit for roundtrip delay, does not contribute to total verdict
check roundtrip delay objective	Boolean	True	Objective upper limit is checked if True
interaural diff. upper limit (ms)	Double	5	
check interaural diff. upper limit	Boolean	False	
interaural diff. objective (ms)	Double	2	
check interaural diff. objective	Boolean	False	

Echo Control Characteristics

Table 31 Parameters for echo control characteristics test

Name	Type	Value	Explanation
handsfree	Boolean	False	Use devices configured in handsfree settings
CDMA	Boolean	True	Defines 0 dBFS = 3.17 dBm0
max. delay age (h)	Double	0	Not used
crosscorrelation length (samples)	Integer	8192	Length of cross-correlation result
crosscorr. analysis length (samples)	Integer	16384	Number of cross-correlated samples
near-end signal	String	EchoControl_Nearend	The file cannot be changed by the operator
near-end level (dBPa)	Double	-4.7	SPL at MRP
far-end signal	String	EchoControl_Farend_WB	The file cannot be changed by the operator
far-end level (dBm0)	Double	-16	Encoder input level
conditioning time (s)	Double	23.5	Start of the analysis after start of the signal
analysis time 1 (s)	Double	20	Length of continuous double-talk section
analysis time 2 (s)	Double	15	Length of single near-end words section
cat. lower limits for analysis 1 dt (%)	String	0,0,0,0,0,0,0	For categories A, B, C, D, E, F, G, H
check cat. lower lim. for analysis 1 dt	String	False,False,False,False,False,False,False	For categories A, B, C, D, E, F, G, H
cat. upper limits for analysis 1 dt (%)	String	100,100,100,100,100,100,100	For categories A, B, C, D, E, F, G, H
check cat. upper lim. for analysis 1 dt	String	False,False,False,False,False,False,False	For categories A, B, C, D, E, F, G, H
level lower limits for analysis 1 dt (dB)	Double	0,0,0,0,0,0,0	For categories A, B, C, D, E, F, G, H
check level lower lim. for anal. 1 dt	String	False,False,False,False,False,False,False	For categories A, B, C, D, E, F, G, H
level upper limits for analysis 1 dt (dB)	Double	0,0,0,0,0,0,0	For categories A, B, C, D, E, F, G, H

Name	Type	Value	Explanation
check level upper lim. for anal. 1 dt	String	False,False,False,False,False,False,False	For categories A, B, C, D, E, F, G, H
cat. lower limits for analysis 1 st (%)	Double	0,0,0,0,0,0,0	For categories A, B, C, D, E, F, G, H
check cat. lower lim. for analysis 1 st	String	False,False,False,False,False,False,False	For categories A, B, C, D, E, F, G, H
cat. upper limits for analysis 1 st (%)	String	100,100,100,100,100,100,100	For categories A, B, C, D, E, F, G, H
check cat. upper lim. for anal. 1 st	String	False,False,False,False,False,False,False	For categories A, B, C, D, E, F, G, H
level lower limits for analysis 1 st (dB)	Double	0,0,0,0,0,0,0	For categories A, B, C, D, E, F, G, H
check level lower lim. for anal. 1 st	String	False,False,False,False,False,False,False	For categories A, B, C, D, E, F, G, H
level upper limits for analysis 1 st (dB)	Double	0,0,0,0,0,0,0	For categories A, B, C, D, E, F, G, H
check level upper lim. for anal. 1 st	String	False,False,False,False,False,False,False	For categories A, B, C, D, E, F, G, H
cat. lower limits for analysis 2 dt (%)	String	0,0,0,0,0,0,0	For categories A, B, C, D, E, F, G, H
check cat. lower lim. for analysis 1 dt	String	False,False,False,False,False,False,False	For categories A, B, C, D, E, F, G, H
cat. upper limits for analysis 2 dt (%)	String	100,100,100,100,100,100,100	For categories A, B, C, D, E, F, G, H
check cat. upper lim. for analysis 2 dt	String	False,False,False,False,False,False,False	For categories A, B, C, D, E, F, G, H
level lower limits for analysis 2 dt (dB)	String	0,0,0,0,0,0,0	For categories A, B, C, D, E, F, G, H
check level lower lim. for anal. 2 dt	String	False,False,False,False,False,False,False	For categories A, B, C, D, E, F, G, H
level upper limits for analysis 2 dt (dB)	String	0,0,0,0,0,0,0	For categories A, B, C, D, E, F, G, H
check level upper lim. for anal. 2 dt	String	False,False,False,False,False,False,False	For categories A, B, C, D, E, F, G, H
cat. lower limits for analysis 2 st (%)	String	0,0,0,0,0,0,0	For categories A, B, C, D, E, F, G, H
check cat. lower lim. for analysis 2 st	String	False,False,False,False,False,False,False	For categories A, B, C, D, E, F, G, H
cat. upper limits for analysis 2 st (%)	String	100,100,100,100,100,100,100	For categories A, B, C, D, E, F, G, H
check cat. upper lim. for anal. 2 st	String	False,False,False,False,False,False,False	For categories A, B, C, D, E, F, G, H
level lower limits for analysis 2 st (dB)	String	0,0,0,0,0,0,0	For categories A, B, C, D, E, F, G, H
check level lower lim. for anal. 2 st	String	False,False,False,False,False,False,False	For categories A, B, C, D, E, F, G, H
level upper limits for analysis 2 st (dB)	String	0,0,0,0,0,0,0	For categories A, B, C, D, E, F, G, H
check level upper lim. for anal. 2 st	String	False,False,False,False,False,False,False	For categories A, B, C, D, E, F, G, H
handsfree	Boolean	False	For categories A, B, C, D, E, F, G, H

7 Measurements with electric connections

Introduction

Usually the mobile under test is connected via RF connection to the R&S CMU200 and via acoustic interfaces (artificial mouth and ear) to the R&S UPV. Therefore no intrusion in the mobile device is required.

There may, however, be cases during the design process of a mobile phone where the usual interfaces are not available:

- if a mechanic mockup is to be measured just with the acoustic components but without the rest of the circuitry
- if a circuit of a mobile phone is to be measured without acoustic components
- if a hands free kit or headset is to be measured without mobile phone
- if the hands free or headset connection of a mobile phone is to be measured without hands free kit or headset, respectively.

In these cases either coder and decoder or artificial ear and artificial mouth may be replaced by direct electrical connections to the R&S UPV. To use electric connections, select “Electric connection” in the respective item of the “Options” menu.

Calibration values for electric connections

Electrical connections cannot be calibrated. Instead a virtual sensitivity has to be entered for each type of electrical connection under “Calibration → Electric connections → ...”.

Electric connection replacing artificial ear

R&S UPV Analyzer input 1 is directly connected to the earpiece amplifier output.

A nominal sensitivity of the receiver (earpiece speaker) for which the circuit is intended has to be entered in dB re 1 Pa/V.

Electric connection replacing artificial mouth

R&S UPV generator output 1 is directly connected to the microphone input of the mobile phone circuit.

A nominal sensitivity of the microphone for which the circuit is intended has to be entered in dB re 1 V/Pa.

Electric connection replacing encoder

R&S UPV generator output 2 is directly connected to a earpiece or headset speaker or to the speech input of a hands free kit.

A nominal full scale output voltage (output voltage corresponding to digital full scale) of the circuit intended to drive the speaker or car kit has to be entered.

Electric connection replacing decoder

R&S UPV analyzer input 2 is directly connected to a microphone or to the speech output of a hands free kit.

A nominal full scale input voltage (input voltage corresponding to digital full scale) of the respective microphone or speech input has to be entered.

Performing the measurements

After applying the settings in the “Options” menu and after entering appropriate calibration values for the electric connections in use, the measurements may be started as usual.

Some parts of the standard require the use of particular artificial ears for particular measurements. Therefore the checkbox “Allow only selected measurements” should be unchecked in “Options → Standard”.

For sending tests, the output voltage range in the R&S UPV is set to a large value in order to be able to drive the speaker of the artificial mouth. In rare cases sending distortion and/or sending noise results may be degraded with electric connections if a low microphone sensitivity is entered. In this case please contact R&S support.

8 Automatic Test Sequences

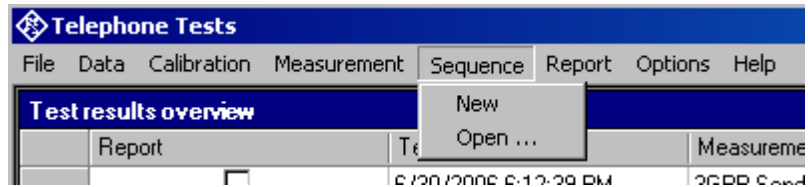

Fig. 148 Sequence menu

Creating and Editing a Sequence

The menu item “Sequence → New” first produces a window where a name for the new sequence has to be entered. Subsequently the sequence window opens.

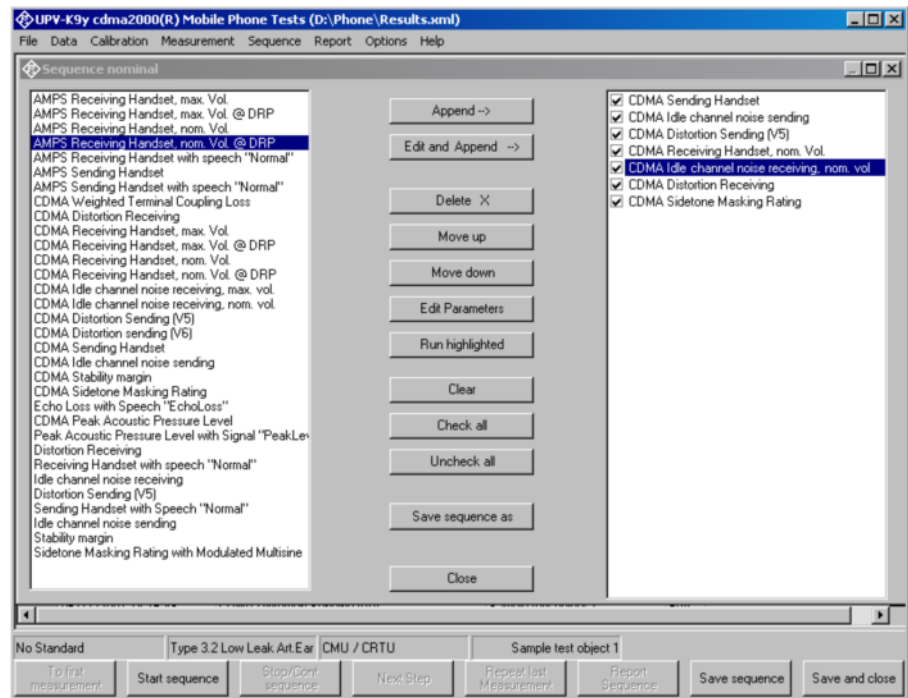

Fig. 149 Sequence window

Initially the right checked list box is empty. The list box on the left side displays all available measurement definitions. A measurement is appended to the sequence by highlighting it in the list box on the left side and clicking the “Append” button. Subsequently a measurement, which is highlighted in the checked list box on the right side, can be moved within the sequence using the buttons “Move up” and “Move down” and deleted from the sequence with the “Delete X” button. For non-standard measurements which allow to change parameters like limit curves, it is possible to edit the parameters before appending the measurement to the sequence. This is done by clicking the button “Edit and append”. It is for example possible to assemble a test sequence which contains stability margin tests with different loop gains.

A sequence should be run with option “Show operator instructions” disabled. This avoids interruption of the execution. If a message to the operator is to be inserted into the sequence on purpose, e.g. “Set user volume control to maximum!”, the items provided in the tree view under “Messages and Control” may be used. Such a message will stop the execution of the sequence until it is closed by acknowledgement of the operator.

Remote Control of R&S CMU200 within a Sequence

It is possible to remote control radiocommunication tester R&S CMU200 from the R&S UPV within an automatic test sequence, for example to wait for a mobile to register, or for originating a call to the mobile. First the connection interface to the R&S CMU200 has to be set up using menu item “Options → CMU remote control”. To insert a control instance into a sequence, choose one of the examples offered in branch “Messages and Control” of the tree view and edit it if necessary. For details on the remote control of the R&S CMU200 see the respective operation manuals.

Each control instance consists of a block of an arbitrary number of remote commands followed by a status query. The query command (e.g. “SIGN:STAT?”) and the response to wait for (e.g. “SYNC” or “CEST”) can be specified as well as a timeout for the case that the desired response is not received. As the R&S CMU200 is organized into subsystems for the different mobile phone systems, the subsystem has to be specified as a parameter. Parameter “Auto” causes the control instance to use the subsystem set with menu item “Options → CMU Subsystem”. Note that the remote commands are not always compatible between different mobile phone systems.

In addition, a message to the operator like “Please switch on the mobile!” can be entered in the “Operator Instruction” field of the parameter window. Parameter 1 allows to choose whether the message is shown before or after the block of commands is sent to the R&S CMU200.

When the R&S CMU200 control instance is executed within a sequence, a window opens, showing the progress of the control action.

Note: *By default, the R&S CMU200 changes its state when switching from local control to remote control or vice versa. As a consequence, synchronicity / registration or an established call would be lost during the transition. Therefore the command “SYSTem:GTRMode:COMPAtible OFF” has to be issued before the first real remote control instance. Insert “CMU run this first!” in your sequence before any other remote CMU remote control.*

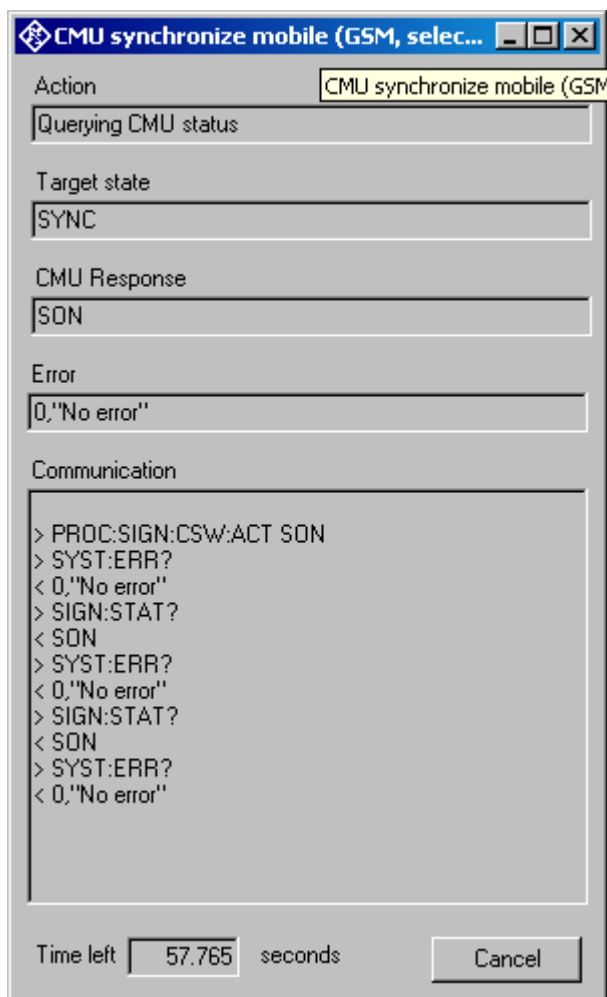

Fig. 150 CMU remote control window

“Action” shows the current remote control action. “Target state” shows the desired query response. “CMU Response” shows the actual response of the R&S CMU200 to the query. Error information returned from the R&S CMU200 after the last command / query is displayed in the “Error” field. The “Communication” box lists all commands and responses issued during the control process. During the status query, the box “Time left” shows the time left until the timeout expires.

Opening an Existing Sequence

The menu item “Sequence → Open ...” opens a file selector for specifying the sequence to be loaded. The sequence window opens with the specified sequence loaded. The sequence can then be edited and/or run.

Running a Sequence

When the softkey “Start sequence” is pressed, all checked measurements in the right list box are executed in sequence. The state of the checkboxes may be altered by marking a measurement and then clicking on the checkbox.

A running sequence may be interrupted with one of the buttons in the measurement control window which is visible while a measurement is

running. “Cancel and continue sequence” cancels the currently running measurement and resumes execution of the sequence with the next measurement. “Cancel and stop sequence” aborts both running measurement and sequence. “Stop sequence after this measurement” completes the running measurement and stops the sequence afterwards.

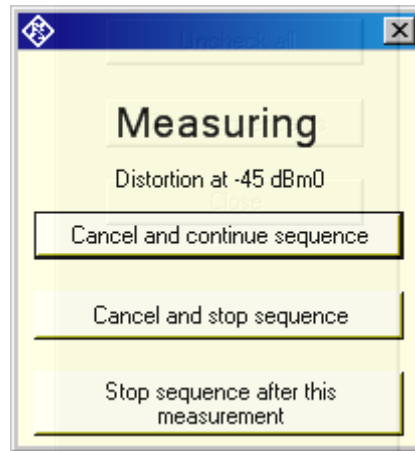

Fig. 151 Measurement control window

Running a single measurement out of a sequence

If a measurement is highlighted in the right checked list box it can be run like a single measurement using the button “Run highlighted”, irrespective of whether it is checked or not. The measurement runs as if it would have been started from the “Measurement” menu in the main window. That is, the measurement window stays open for further actions like storing and loading of curves and reporting until it is closed by the user. This functionality allows to assemble subsets of customized measurements without overloading the list in the “Measurement” menu.

Reporting on Sequence Results

A report on all executed measurements of the last run sequence is prepared and displayed after the “Report Sequence” softkey has been pressed. After the sequence window has been closed, a report on the last sequence can be obtained by pressing the “Report last sequence” softkey in the main window.

9 Reporting, Storing, Loading and Deleting Results

Result Files

Measurement results are stored together with all associated data in XML files. Separate files can be used for different projects or operators. They can be archived together with other project data and re-opened later for generating reports.

It is recommended to keep result files small and to generate backups at frequent intervals.

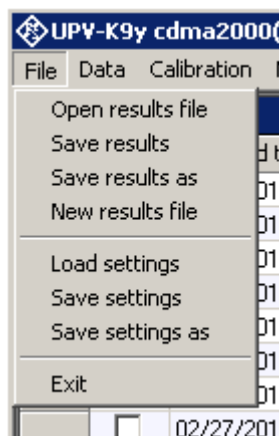

Fig. 152 File menu

A new (empty) result file can be created with "File → New Result File" from the main menu.

An existing result file can be opened with "File → Open Result File" from the main menu.

A currently opened result file can be stored under a new name with "File → Store results as" from the main menu.

Report Settings

With "Report → Settings" or "Options → Report settings", a selection can be made of data which should appear in the reports. Thus, information which is the same for a larger number of measurements does not have to be printed with every report again.

Generating a Single Report

A report on a single measurement result can be generated from the window of a measurement macro by clicking or pressing the softkey "Generate report".

From the result overview of the main window, a report on a single measurement can be generated by marking the row with the selected result by clicking on the row header to the left, right-clicking into the data grid and selecting "Generate report" from the context menu.

Subsequently data associated with the selected measurement is

assembled, a graph for existing curve data is generated, and the preview window is opened. Depending on the amount of measurement data, this may take a few seconds.

Selection Report

A report on a selection of measurements can be generated from the results overview data grid in the main window by checking the rows with the desired results in the "Select" column and choosing item "Report Selection → Report Selected Results". Rows checked in the "Select" column will be added to the report. The selection can be toggled by clicking into the respective "Select" cells.

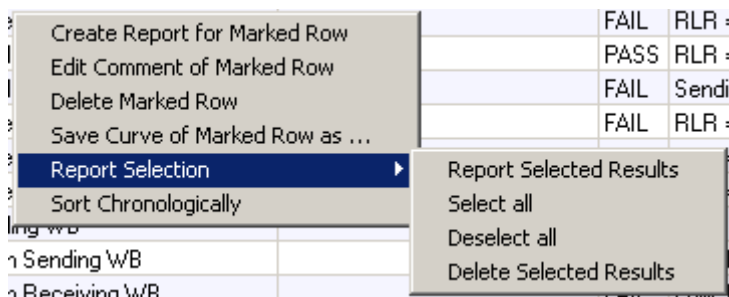

Fig. 153 Results context menu

Generating a Sequence Report

A report on a sequence of measurements can be generated from the sequence window by clicking or pressing the softkey "Report sequence".

Once the sequence window has been closed, a report on the last executed sequence can be generated by selecting "Report → Last sequence" from the main menu. Reports about previous sequences can be generated as single reports on the measurements of this sequence, as all results appear in the overview data grid in the main window.

Preview Window

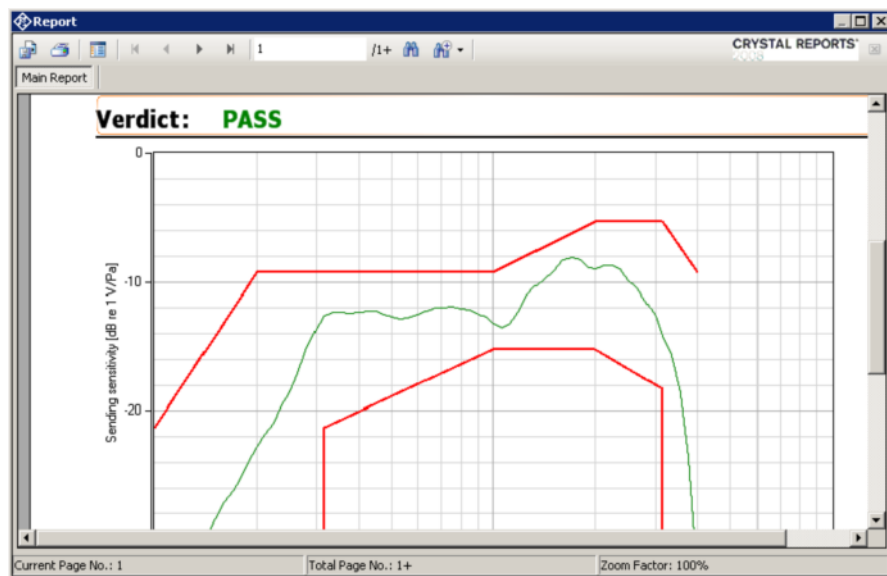
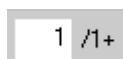

Fig. 154 Report preview window

The main area of the preview window shows a preview of the report as it will be printed or appear in an exported PDF file. If the report comprises more than one page, the pages can be browsed using the buttons



Alternatively, a page number can be directly entered in the page number field



To open the print dialog for installed windows printers click



To open a file selector for export of the report to Crystal Reports report format, PDF, WORD, EXCEL, EXCEL-Data only format, Rich Text or editable Rich Text format, click



The scale of the document in the preview can be adjusted with

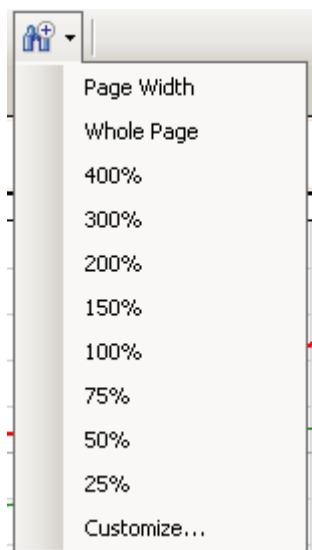

Fig. 155 Scale menu of the preview window

Storing and Loading Curves from Measurement Windows

Measured curves can be stored from and loaded into the graph of a measurement macro (see above). This allows easy import into spreadsheets as well as direct comparison of curves measured at different times or places. Measured curves can also be stored in a R&S UPV limit file for use as a limit curve either in a R&S UPV sweep graph or in the graph of a R&S UPV-K9/K92 window. This allows e.g. to derive tolerance schemes from “golden devices”. The measured curve can be arbitrarily shifted before being stored.

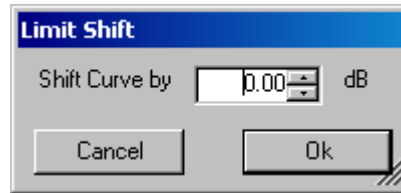

Fig. 156 Input window for defining a shift of a measured curve for storage as limit curve

Storing and Loading Curves from the Results Overview

With menu item “Save Curve of Marked Row As ...” in the results context menu it is possible to export curve data to ASCII files. If more than one curve is present for the marked result, a selection window prompts to choose the curve(s) to be saved to a file. The data can be saved in Tab separated (*.txt) and comma separated (*.csv) format.

ASCII Result Files

When the item “Generate temporary export files” in the “Options” menu is checked, the standard tests generate “abscurve.exp”, “relcurve.exp” and “result.exp” files similar to those generated by UPL-B9. These files are always deleted and overwritten by subsequent tests.

Deleting Results

It may be desirable to delete results of selected measurements from the result file, e.g. because the measurement was repeated due to a missing call to the mobile, a wrong setting etc. To delete the result of a particular measurement, mark the row for the selected measurement in the data grid of the main window by clicking on the row header to the left, right-click into the data grid and select “Delete result” from the context menu. After confirmation by the operator, the selected row of the result overview will be deleted from the result file together with all associated data.

A set of results may be selected in the “Select” column of the results data grid and commonly deleted using the context menu item “Report Selection → Delete Selected Results”.

Automatic Backup and Restoration of the Results File

In order to speed up the execution of sequences, the result file is only saved when the program is closed. However, backups of the result file called “*.xml~1” and “*.xml~2” are stored alternately after termination of each single measurement and after termination of each sequence (“*” stands for the name of the results file without extension). If the program is ended without closing it properly, or if the result file is not existing anymore, the R&S UPV-K9 will by the time of its next start offer to restore the result file from the latest backup file:

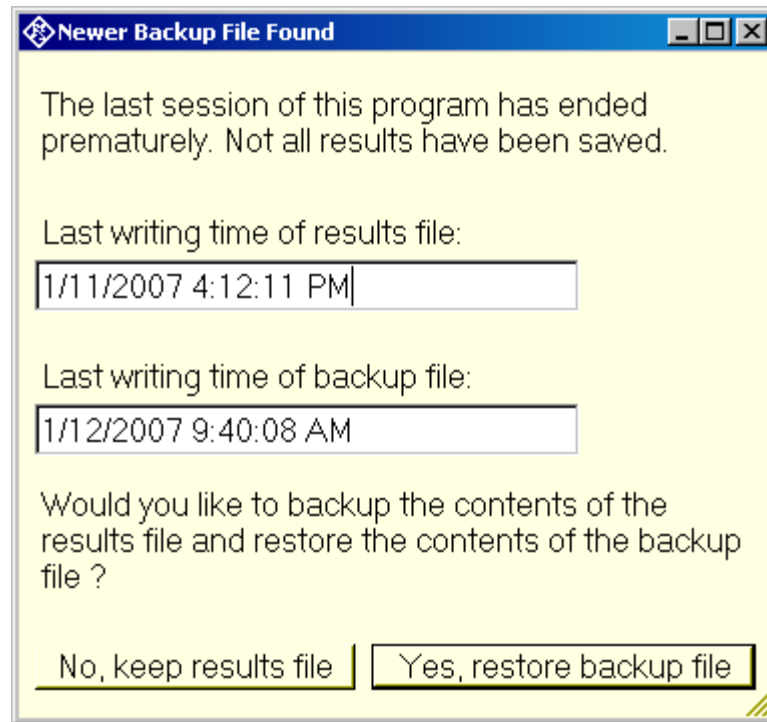

Fig. 157 Restoration of data from backup file

If it is chosen to restore the result file from the backup, the supposedly damaged result file is copied do “*.xml~3” before the backup file is copied to the original name of the results file.

10 Remote Controlled Start of Testcases via GPIB

Preparations

- Start the K9y test program on the R&S UPV.
- In the “Options” menu, deactivate item “Show operator instructions” and activate “Generate temporary export files”.
- If it is desired to download screenshots from the R&S UPV to the host, activate also “Generate temporary image files” in the Options menu.
- Activate “Enable remote control” in the Options menu
- Do all necessary settings and calibrations as would be done for manual control.

Starting a Measurement

A measurement can be started with remote command:

```
SYST:PROG:EXEC  
'C:\ControlK9.exe D:\Phone\3G2_rcv_handset_narrow_nom.mdf.mdf
```

wherein “ControlK9.exe” is the client program controlling the application and “D:\Phone\3G2_rcv_handset_narrow_nom.mdf” specifies a file which defines the test to be executed. A list of files for various tests is given separately in the spreadsheet file “TestCaseList_K9y_300.xls”. The file name must be separated from the program name by a space character. Thus it is recognized by the client program as a command line parameter.

Attention: Do not attempt to control the UPV-K9y software locally while a remotely started test case is running.

Reading the Results

Result values and curves are available in memory buffers in the R&S UPV firmware according to the following tables:

Table 32 Assignment of string buffers for result values

String Buffers	
1	Title <Tab> Date <Tab> Time
2	Total verdict
3	Result 1 heading
4	Result 1 value
5	Result 1 verdict
6	Result 2 heading
7	Result 2 value
8	Result 2 verdict
9	Margin 1 (upper) heading
10	Margin 1 (upper) value
11	Margin 2 (lower) heading
12	Margin 2 (lower) value
13	Margin 3 heading
14	Margin 3 value
15	Margin 4 heading
16	Margin 4 value
17	Delay heading
18	Delay value
19	Error message
20	Result 3 heading
21	Result 3 value
22	Result 3 verdict
23	Result 4 heading
24	Result 4 value
25	Result 4 verdict
26	Result 5 heading
27	Result 5 value
28	Result 5 verdict
29	Result 6 heading
30	Result 6 value
31	Result 6 verdict
32	Result 7 heading
33	Result 7 value
34	Result 7 verdict

String buffers can be queried using the remote command

SYSTEM:MEMory:STRing<i>?

Table 33 Assignment of trace buffers for result curves

Trace Buffers	
1	Result 1 (absolute) curve X values
2	Result 1 (absolute) curve Y values
3	Result 1 shifted / upper limit X values
4	Result 1 shifted / upper limit Y values
5	Result 1 lower limit X values
6	Result 1 lower limit Y values
7	Result 1 relative curve X values
8	Result 1 relative curve Y values
9	Result 2 (absolute) curve X values
10	Result 2 (absolute) curve Y values
11	Result 2 shifted / upper limit X values
12	Result 2 shifted / upper limit Y values
13	Result 2 lower limit X values
14	Result 2 lower limit Y values
15	Result 2 relative curve X values
16	Result 2 relative curve Y values

Trace buffers can be queried using the remote command

```
SYSTem:MEMory:DATA<i>?
```

Results are also available in files “D:\Phone\result.exp”, “D:\Phone\relcurv.exp” and / or “D:\Phone\abscurv.exp”, depending on the type of measurement. If “Options → Generate temporary image files” is activated, a screenshot of the last finished test is available in “D:\Phone\Image.TIF”. The command for the file transfer is (for the example of the results file)

```
MMEM:DATA? 'D:\ Phone\result.exp '
```

All results are stored in the database. However, it is not possible to change the test object remotely. The results can be identified later by the test time given in the “result.exp” file.

Determining the Termination of a Measurement

A running test is indicated with bit 13 of the Operation register in the status system set. It is recommended to configure a service request on the GPIB for a negative transition of this bit:

```
STAT:OPER:NTR 8192
```

```
STAT:OPER:ENAB 8192
```

```
*SRE 128
```

A service request will be issued as soon as the test has terminated.

To avoid obsolete result files to be downloaded from the R&S UPV, existing result files can be deleted before the start of the measurement, using the commands:

```
MMEM:DEL 'D:\ Phone\result.exp'
```

```
MMEM:DEL 'D:\ Phone\relcurv.exp'
```

```
MMEM:DEL 'D:\ Phone\abscurv.exp'
```

Note that an attempt to delete a non-existing file will lead to an entry in the error queue. The error queue can be flushed using the query “SYST:ERR?” until the response is ‘0,’No error’. Alternatively existing files can be overwritten by uploading empty files with the same name. Downloaded files can then be checked for their size before they are processed further, to determine whether they are empty dummy files.

For further details on remote control of the R&S UPV via GPIB and on the remote commands mentioned above please see the user manual of the R&S UPV.

11 Terminating the Application

The measurement can be terminated from the main window with the “Exit” softkey. This causes the result file to be written to the hard disk.

12 Appendix A Settings on the Radio Communication Tester CMU200

Hardware and firmware requirements:

- The R&S®CMU200 must be equipped with option R&S®CMU-B41, Audio Generator and Analyzer *.
- Firmware version 3.60 or later must be installed on the R&S®CMU200.
- An XLR-BNC adapter (1 male, 1 female) and two BNC cables for connecting the R&S®CMU AUX connectors to the R&S UPV are required. These adapters are part of R&S UPV-K9.

* If option R&S®CMU-B41 was not installed at the factory, internal FM auto-calibration of the R&S®CMU200 must be run one time after installation.

Set all necessary AMPS settings in the AMPS menu of the R&S®CMU200. To activate the external speech connection at AUX1 and AUX2, you must switch AF Gen to ON and select external reference as the modulation source:

- From the OVERVIEW menu, press **AFMod.Gen**.
- Press **Mod.G.Deviation** and set it to ON with the **ON/OFF** key (the deviation value has no influence).

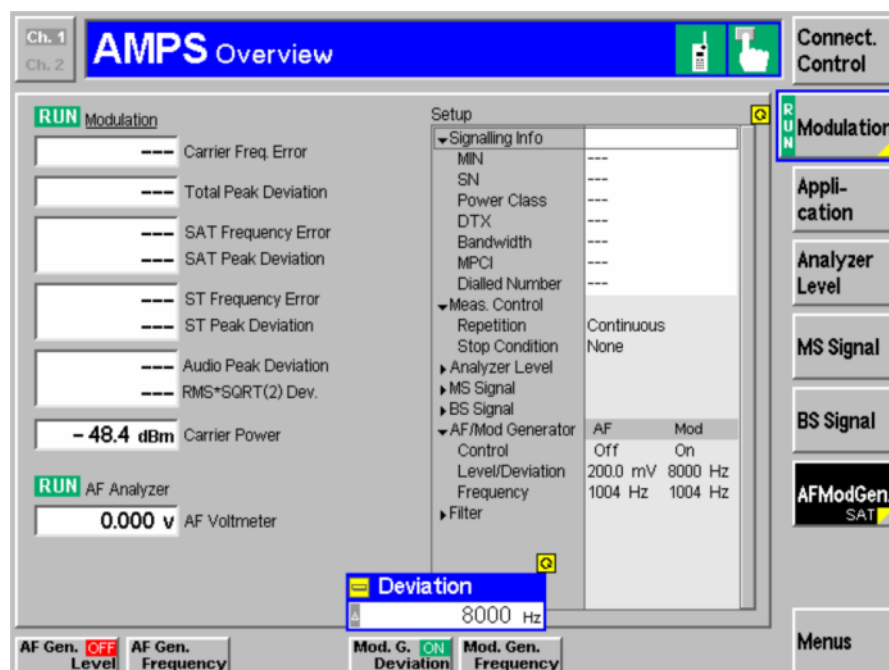

Fig. 158 AMPS overview menu of the CMU200

- Go to the Connection menu and press **AF/RF**.
- Using the **Mod.Source** key, select **Mod.externRef**.

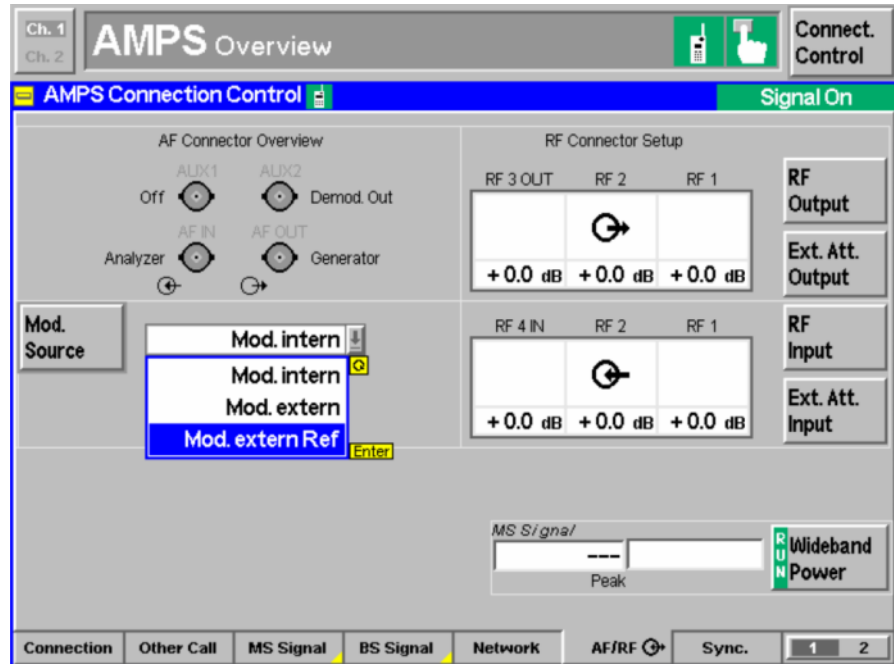

Fig. 159 Selecting the modulation source for AMPS on the CMU200

Important: If the generator cannot be operated after Mod.externRef is selected, the generator must first be switched on!

The program allows to measure the sending and receiving characteristics in the AMPS mode. The measured loudness value as well as the frequency response are displayed as in the digital mode. The contrast is the difference between the measured loudness rating of the mobile in analog mode and in digital mode. When an AMPS test is performed, the program automatically scans the result data base for matching results in cdma mode (same device under test, same kind of measurement). If such results exists, the latest of them is retrieved and used for loudness contrast calculation.

The call must be established in the cdma mode. The standard settings are SO3 8k Enhanced (low) (EVRC) codec. You should first perform both the sending and receiving measurements in the cdma mode and then the analog measurements in the AMPS mode, because the call is interrupted after fallback from AMPS to cdma.

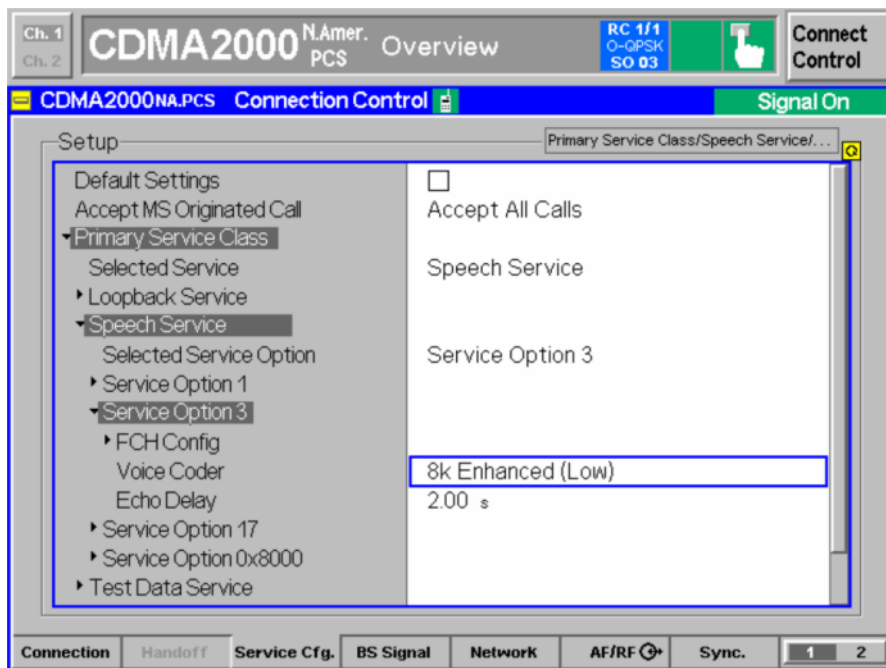

Fig. 160 Voice coder settings for CDMA2000 on the CMU200

For the AMPS measurements in the Handoff menu, select the setting AMPS fallback. After the HANDOFF key has been pressed, the R&S@CMU200 makes a handoff to AMPS using the previously (in the AMPS menu) selected AMPS parameters. The AMPS parameters can also be set with the Destination Parameter key.

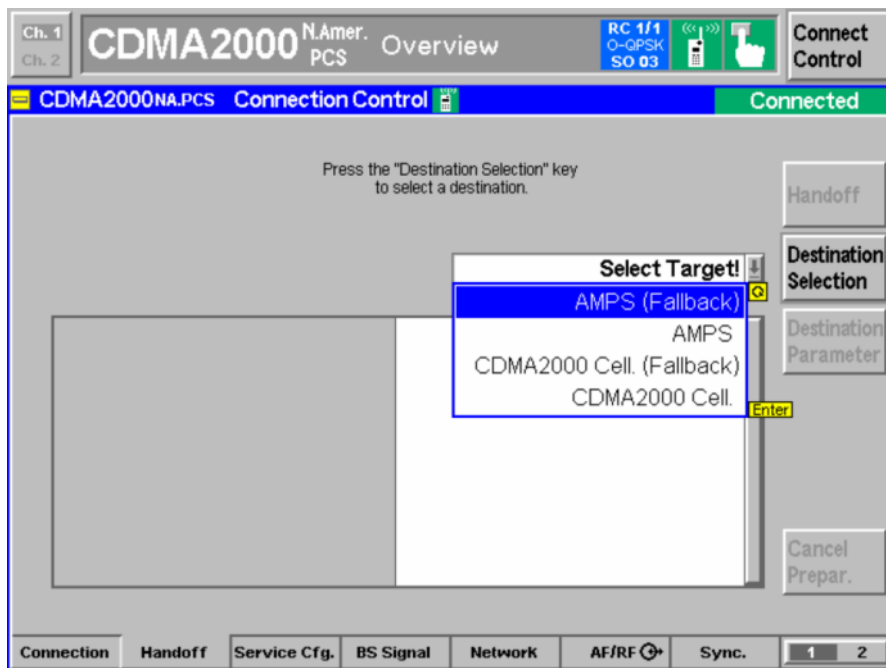

Fig. 161 Selecting the fallback target on the CMU200

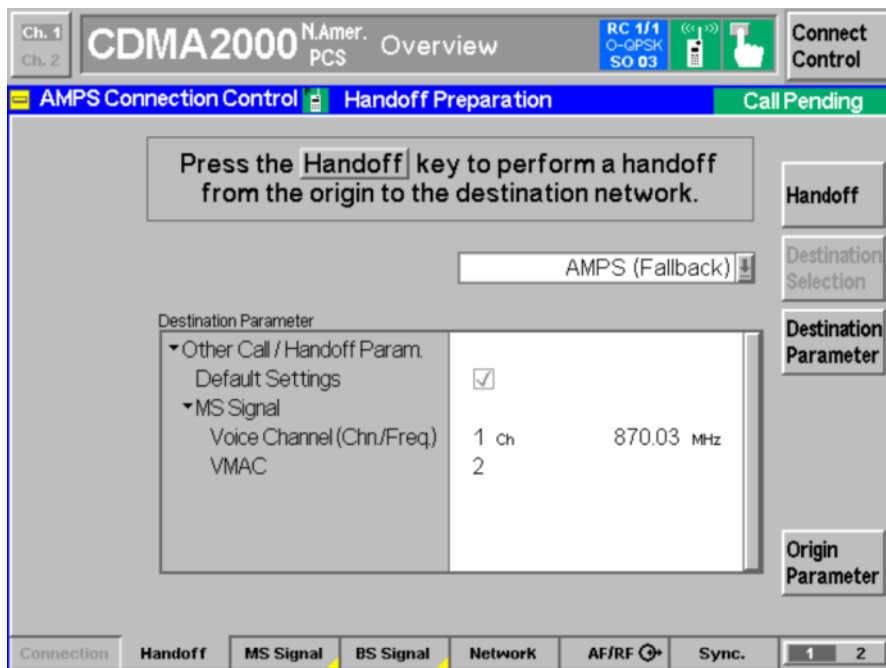

Fig. 162 Setting the AMPS parameters for fallback on the CMU200

The connection from the R&S UPV to the R&S@CMU200 for the speech signal must be changed for this measurement. The generator 2 output from the R&S UPV must be connected with the AUX1 input of the R&S@CMU, and the analyzer 2 input of the R&S UPV must be connected with the AUX2 output of the R&S CMU. To do this, remove the cable from the R&S UPV to the R&S CMU speech connector and make the connections to the AUX BNC connectors.

CDMA2000® is a registered trademark of the Telecommunications Industry Association (TIA – USA).

13 Appendix B Settings on the Radio Communication Tester CMW500

Hardware and firmware requirements:

- Besides the basic hardware, the R&S®CMW500 must be equipped with option R&S®CMW-B400B, R&S®CMW-B405A, R&S®CMW-B200A, R&S®CMW-B220A and R&S®CMW-PK80.
- Firmware Base version 3.2.70 or later, CDMA2000 version 3.2.83 or later and Audio version 3.2.30 or later must be installed on the R&S®CMW500.
- Two XLR-BNC adapters (1 male, 1 female) and two BNC cables for connecting the R&S®CMW500 AF1 IN and AF 1 OUT connectors to the R&S UPV are required. These adapters are part of R&S UPV-K9.

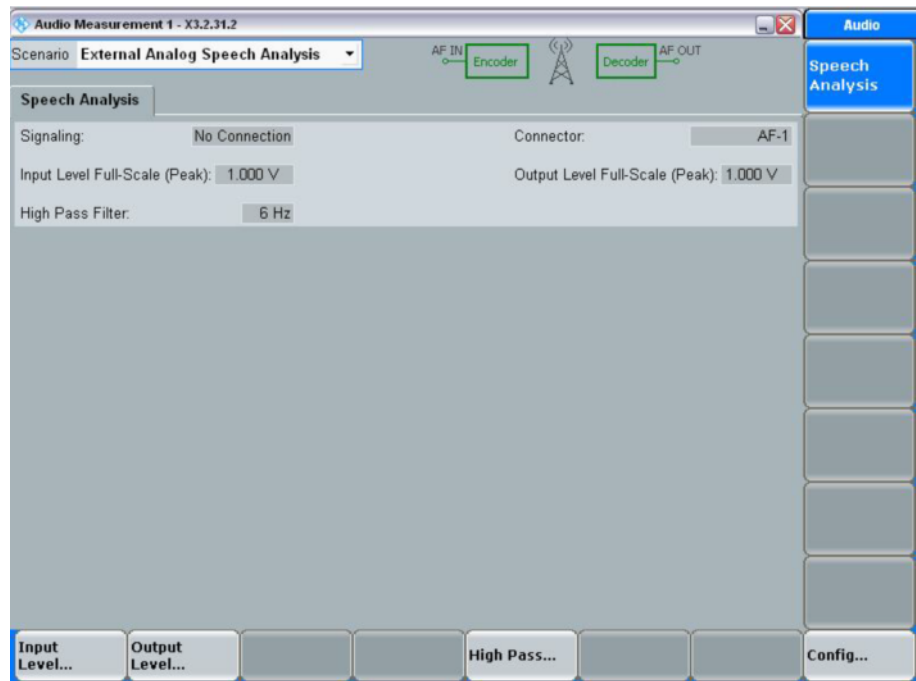

Fig. 163 Audio measurement settings on the CMW500

The input and output full-scale peak levels must be set to the same values as entered in "Calibration → Codec → CMW". "Scenario" must be set to "External Analog Speech Analysis".

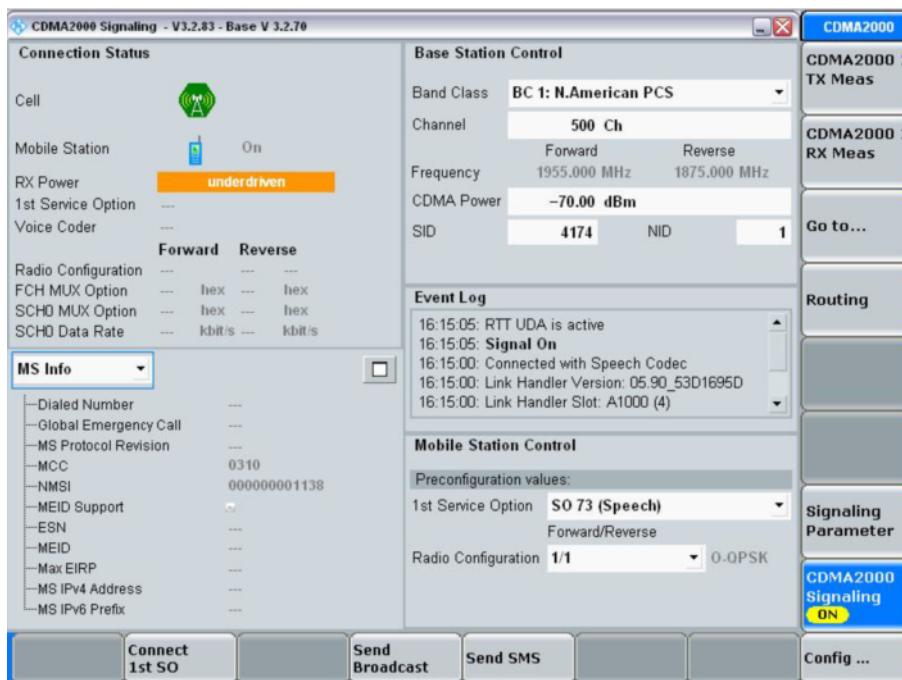

Fig. 164 Example of CDMA2000 signaling settings on the CMW500

For narrowband acoustic tests either service option 3 or service option 68 COP0 should be set. For wideband acoustic tests either service option 73 COP0 or service option 70 COP0 should be selected. The COP (codec operating point) is set in the Config page of the CDMA2000 signaling window.

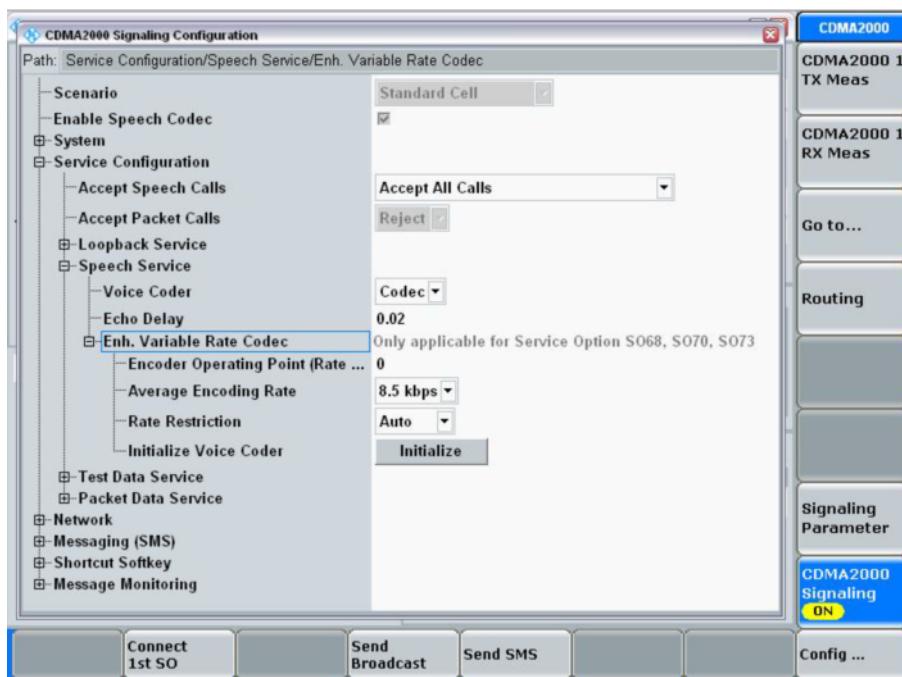

Fig. 165 Example of CDMA2000 signaling configuration on the CMW500

“Enable Speech Codec” must be checked for establishing a speech

connection with the speech codec from/to AF 1 In and AF 1 OUT connectors.